

INSTALLATION INSTRUCTIONS FOR PAD STYLE MOISTURE TESTERS

PLACEMENT OF SENSOR PAD

| | |
|--|----------|
| CONVENTIONAL SMALL SQUARE BALERS | 2 |
| INLINE OR CENTER LINE SMALL SQUARE BALERS | 2 |
| JOHN DEERE ROUND BALERS | 3 |
| NEW HOLLAND AND CASE RBX ROUND BALERS | 3 |
| ALL OTHER ROUND BALERS | 4 |
| INSTALLATION SENSOR PAD AND CABLE | 4 |

****Installation & Operation of the Monitor (Refer to DelmHorst
FX 2000 Manual)***

****Installation of Power Supply (Refer to DelmHorst FX 2000
Manual)***

Placement of Sensor Pad

Conventional Small Square Balers

The sensor pad and crop diverter need to be located in the baler chamber as close to the plunger face as possible. The sensor can be located on the smooth side (outside) or cut side (inside) with the same results for alfalfa hay. The cut side of the bale will give a more accurate reading in grass or alfalfa/grass mixtures because the sensor will be able to see some of the inside plant moisture. A template has been included for marking and drilling the correct holes. Make sure before drilling that when the bolts come through the side of the chamber that they do not interfere or touch any other pieces of metal.

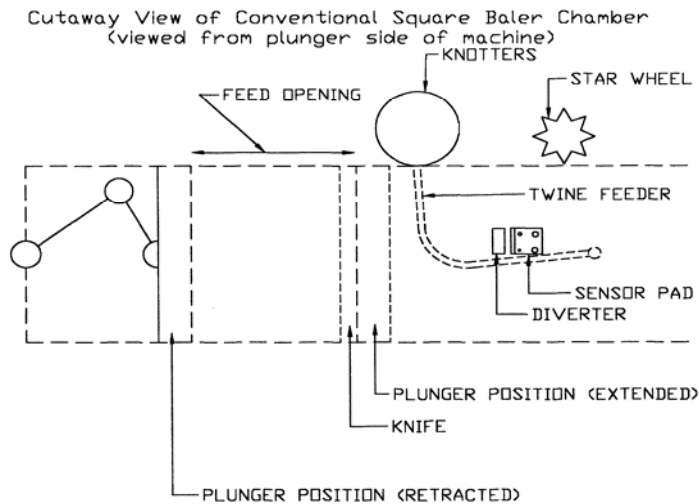

Inline or Center Line Small Square Balers

The sensor pad and crop diverter need to be located in the baler chamber as close to the plunger face as possible. The sensor can be located on the smooth side (top) or cut side (bottom) with the same results for alfalfa hay. The cut side of the bale will give a more accurate reading in grass or alfalfa/grass mixtures because the sensor will be able to see some of the inside plant moisture. A template has been included for marking and drilling the correct holes. Make sure before drilling that when the bolts come through the side of the chamber that they do not interfere or touch any other pieces of metal. Note that if placing in the center channel you may need to cut an opening from the outside to be able to tighten down the nuts and secure the wire or use longer bolts and spacers.

Top View of Inline or Centerline Small Square Baler

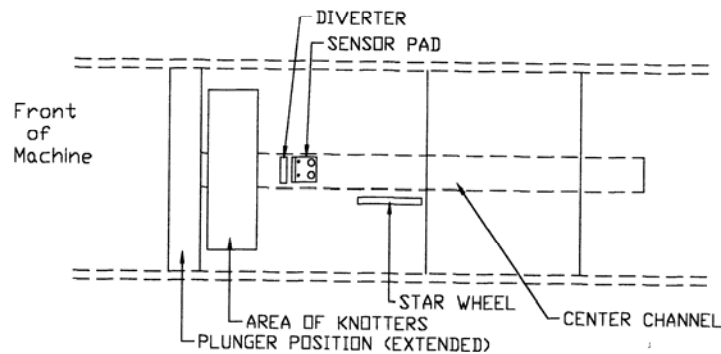

John Deere Round Balers

Locate the sensor pad approximately 4.5" up from the bottom of the frame on the right hand side of the baler as indicated in Figure 1. The back edge of the sensor pad should be vertical so that the top rear corner of the sensor pad is approximately 3/8" forward from the rear edge of the upright frame tube (A). Using the hardware supplied in the kit, mount the sensor to the frame. Make sure that the beveled edge of the sensor pad is facing the front of the baler. You will need to use the long spacers and self tapping screws. The supplied crop diverter will not be used in this installation.

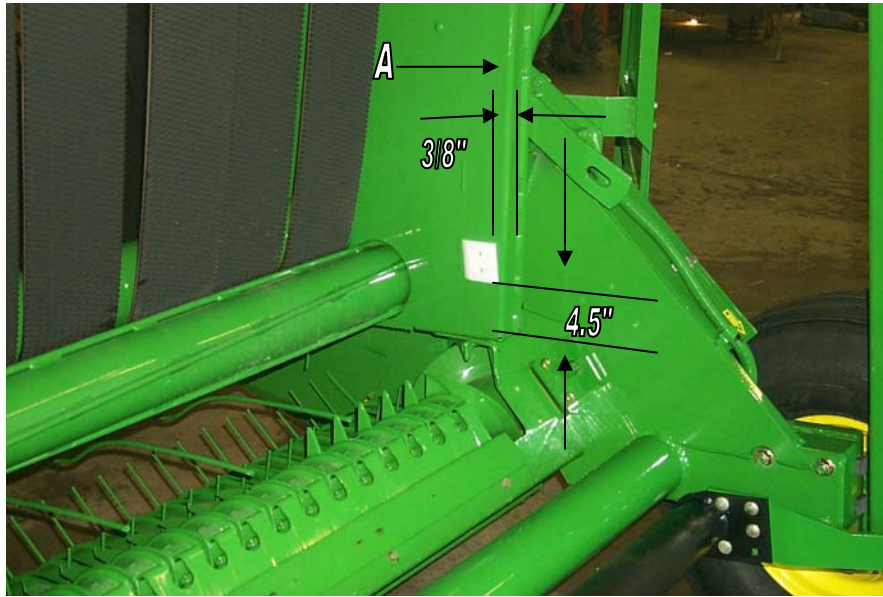

New Holland and Case RBX Round Balers

The sensor pad may be located on either side of the bale chamber. Your baler may contain a circular crop diverter plate. If it does it must be cut. A notch is cut in the plate as shown in the picture below. Re-install the plate, mark and drill holes. A template has been included for marking and drilling the correct holes. Make sure before drilling that when the bolts come through the side of the chamber that they do not interfere or touch any other pieces of metal. You may need to use the long spacers and self tapping screws. The supplied crop diverter will not be used in this installation.

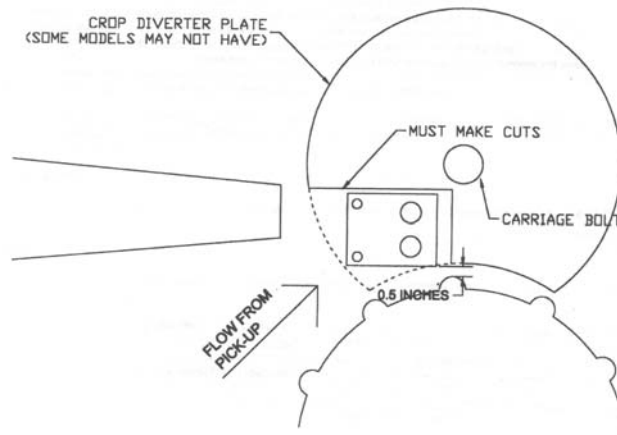

All Other Round Balers

Using the diagram below locate your sensor in the area of the box. Note that it can be installed on either side of the baler. A template has been included for marking and drilling the correct holes. Make sure before drilling that when the bolts come through the side of the chamber that they do not interfere or touch any other pieces of metal. Also look for natural diverters in the baler that could cause the bale to not make contact with the sensor. Remember that we want to get good even pressure against the pad. (**Note if you have a fixed chamber baler you will not get a good reading until the bale is almost complete. We do not recommend using an in chamber moisture tester for these balers**)

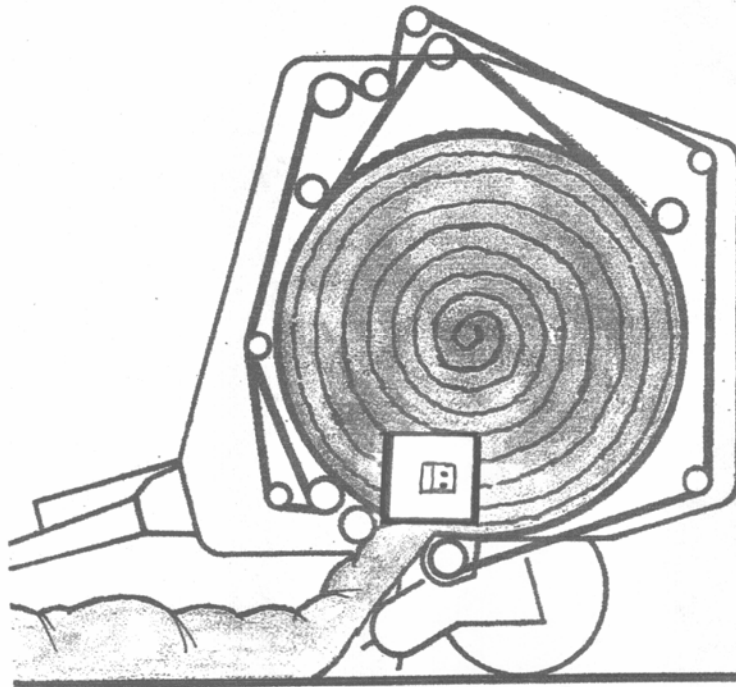

Installation of Sensor Pad and Cable

Once the holes have been drilled. Remove all plastic spacers, lock washers, flat washers, and nuts. Slide sensor plate with carriage bolts into holes. Next place the small plastic spacers onto the carriage bolts and slide into the holes drilled, followed with large plastic spacers. Place flat washer, lock washer, and nut next. Secure front of pad with smaller hardware. Install the cable by first placing a flat washer on the carriage bolts, follow with the cable. It doesn't matter which ring goes on what carriage bolt). Finish by placing another flat washer, lock washer, and nut on the carriage bolt. If your cable has boots on the two wires, slide them over the carriage bolts and snug up against the side of the bale chamber. If your cable does not have boots, you might want to apply silicone over the eye loops, nuts and lock washers. This will prevent a false reading from outside of the bale chamber if chaff accumulates on the bolts and gets them wet. Connect the rest of the cable to the baler using cable ties. Make sure not to connect it to any moving parts. Install crop diverter in front of the sensor pad and secure with hardware provided