

OWNER'S MANUAL

Model 890CNH Scale Interface Kit for CNH balers



P.O. Box 63 • 2821 Harvey Street • Hudson, WI 54016
800-635-7468 • www.harvesttec.com

#010-0890CNH
REVISED 4-10

HARVEST TEC 890CNH TABLE OF CONTENTS

	<u>PAGE</u>
INTRODUCTION	3
OVERVIEW	3
1. INSTALLATION OF SCALE ADAPTER BOX & WIRING DIAGRAM	4
2. SETUP INSTRUCTIONS	5
COMMON QUESTIONS ABOUT THE 890CNH	6
TROUBLE SHOOTING CHECKS	6
WIRING DIAGRAMS	6-7
PARTS BREAKDOWN FOR MODEL 890CNH	8
NOTES	9
WARRANTY STATEMENT	BACK PAGE

INTRODUCTION

Congratulations on purchasing a Harvest Tec Model 890CNH Scale Interface Kit. This kit will allow you to write the exact bale weight into your job records. The kit will also write the rolling average from the last three bales weighed from the CNH scale kit, on the baler, to PRO ID or Crop ID tags if your baler is equipped with a Harvest Tec Model 850 Tagger (U.S. Patent 7,621,111B2 & U.S. Patent 7,415,924B2). The 890CNH will only work with Case IH or New Holland balers with the CNH scale kit installed. For this kit to function you will also need the Harvest Tec Model 500 Moisture Monitor or Harvest Tec model 565 Preservative Application System.

OVERVIEW

The Harvest Tec Model 890CNH Scale Interface Kit is designed to monitor the bale scale communication and intercept the signal when it is transmitted. The 890CNH will collect data from the last three bales and write rolling averages to the tags and will write the exact bale weight in your job records for the bale. The data will then be readable after baling using a Harvest Tec Model 860 Scanner.

1. INSTALLATION OF SCALE ADAPTER BOX & WIRING DIAGRAM

The PIP Interface Controller (PIC) (006-5676) will mount next to the CNH Bale Weighing Controller. The CNH Bale Weighing Controller will be located either under or in the storage box on the back right of the baler. Mark and drill four 5/16 holes next to the bale scale and attach with four 1/4 x 1" bolts and flange nuts.

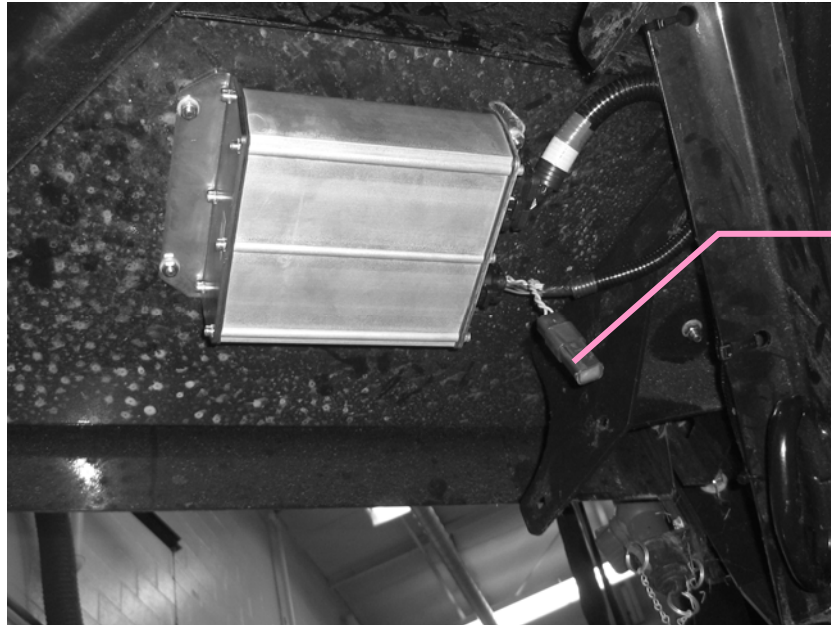

Disconnect the terminating resistor show above. Connect the long side of the CNH interface cable (006-0890N) to this port. Connect the terminating resistor, removed in the first step, to the CNH interface cables short side followed by connecting to the PIC.

Locate a green terminating resistor (006-5650Z) on the Harvest Tec Precision Information Processor (006-5671LS), Pump Controller (006-5672), or Tagger Control (006-5673). The terminating resistor will be at different locations depending on the options installed. Remove the resistor. Connect the communication harness (006-5650F) to the scale adapter and connect to the open port were the terminating resistor was removed from.

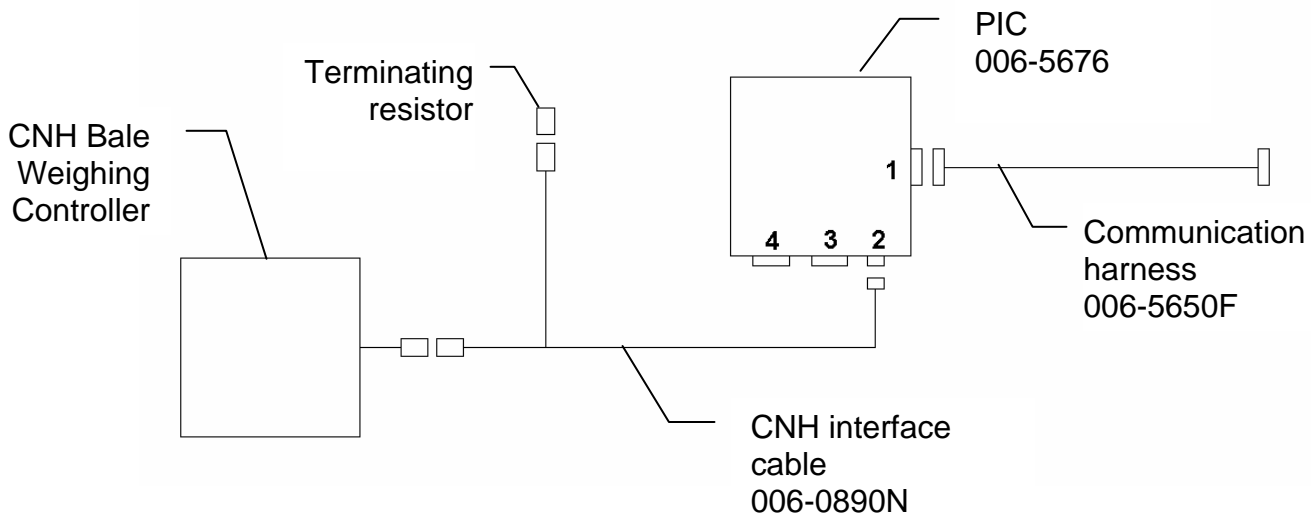

2. SETUP INSTRUCTIONS

1. Turn the 500/565 control system on. After a few seconds the Main Menu screen should appear. Press Setup Mode, the Setup Mode screen will then appear.
2. Press Baling Rate. The Bale Rate Settings screen will then appear.
3. Press the underline 0 next to bale scale. The keypad will then appear. Press 1 followed by enter.
4. The scale is now active in the system.

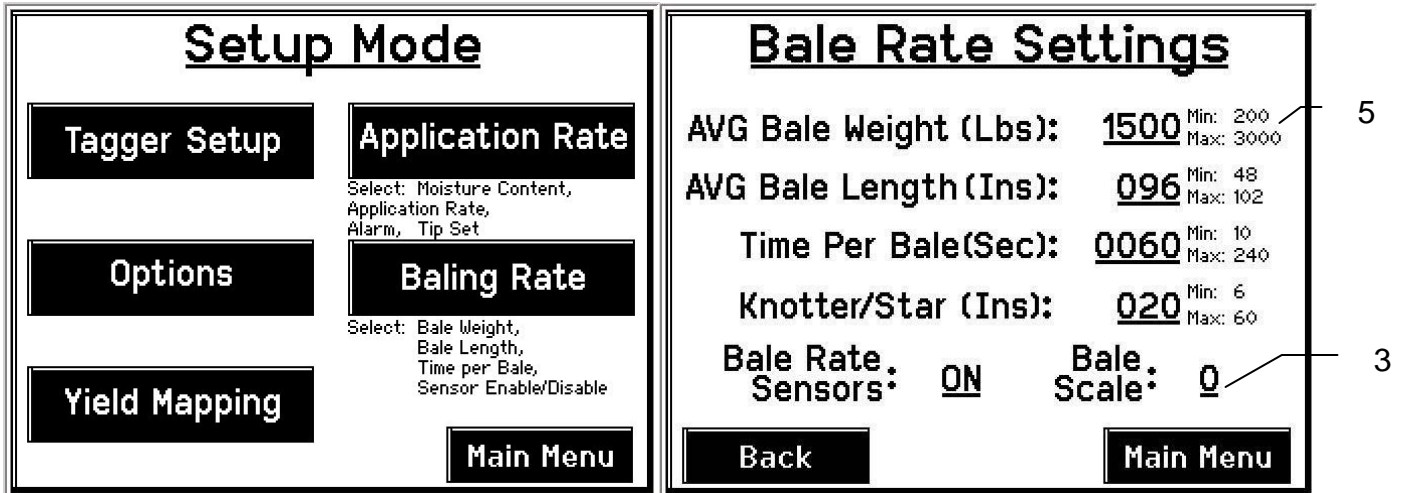

5. The AVG Bale Weight will now adjust for every bale being made. If no signal comes from the scale it will default to your inputted value.

COMMON QUESTIONS ABOUT THE 890CNH

1. Will the 890CNH input the bale weights on my Job Records?

Yes. It will input the bale weight in the Job Records.

2. Why do my Job Records only show the default weight?

The default weight will always be the first weight displayed in the Job Records. After the first bale they should change with the baling conditions. The bale scale needs to be turned on in the PIP. See Setup Instructions. If this is on check all connections and verify the scale is working.

3. What happens if the scale misses a bale weight?

If no signal is found from the scale the system will return to your inputted bale weight. The Job Records and tagged bales will also show the default weight.

4. What weight is written to the tags?

The weight on the tags is a rolling average of the prior three bales.

TROUBLE SHOOTING CHECKS:

<u>PROBLEM</u>	<u>POSSIBLE CAUSE</u>	<u>SOLUTION</u>
Bale weight not correct on Job Records	1. Scale not turned on in Harvest Tec monitor 2. Bad connections	1. Turn scale on in the Bale Rate Settings menu 2. Check all connections and verify scale is functional
Bale weight not correct on tags	1. The first three tagged bales will have the default weight. All remaining bales will have a rolling average of the prior three bales	1. Check other bales. If problem persists check scale and tagging system.

WIRING DIAGRAMS

Communication harness

Pin 1	Red	Can 12 volt
Pin 2	Red	Battery 12 volt
Pin 3	Green	Comm channel OH
Pin 4	Silver	Shield
Pin 5	Yellow	Comm channel OL
Pin 6	Not used	
Pin 7	Not used	
Pin 8	Black	Can ground
Pin 9	Black	Battery ground
Pin 10	Not used	

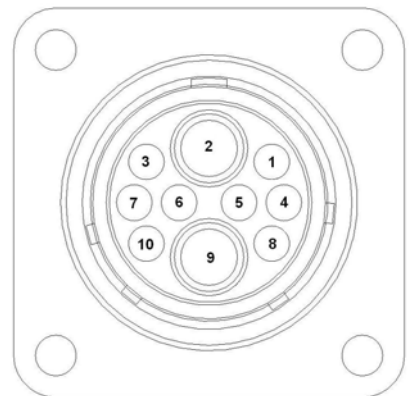

WIRING DIAGRAMS CONTINUED

CNH interface cable

Pin 1	Yellow or Orange	Can channel OH/IH
Pin 2	Green or Blue	Can channel OL/IL
Pin 3	Not used	
Pin 4	Not used	

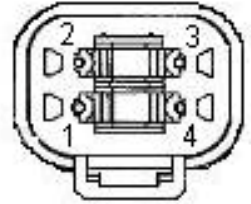

PIC

Pin 1	Yellow	Can channel IH
Pin 2	Green	Can channel IL
Pin 3	Not used	
Pin 4	Not used	
Pin 5	Not used	
Pin 6	Orange	Can channel OH
Pin 7	Blue	Can channel OL
Pin 8		
Pin 9		



PARTS BREAKDOWN FOR MODEL 890CNH

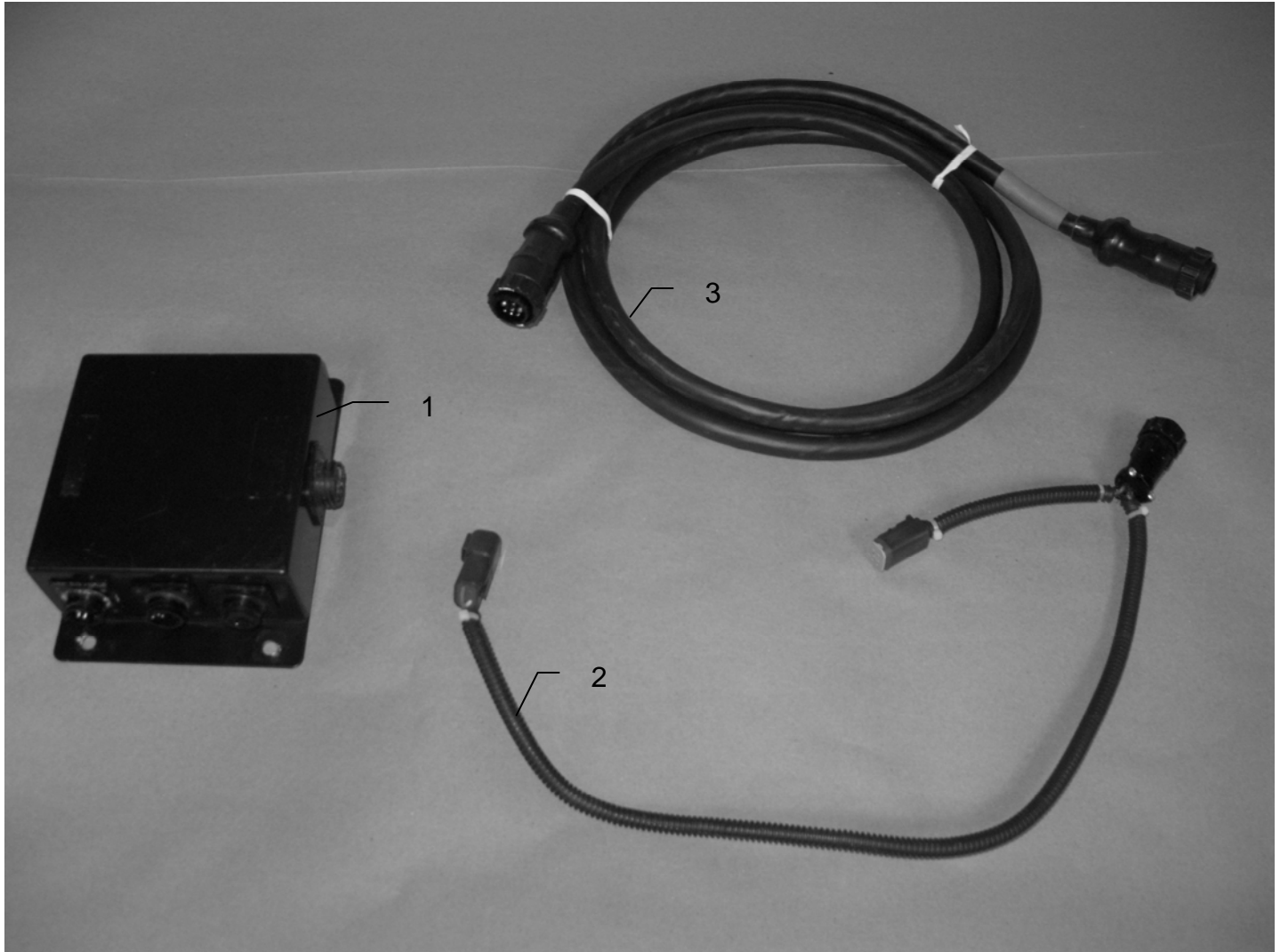

<u>Ref</u>	<u>Description</u>	<u>Part#</u>	<u>Qty</u>
1	PIP interface control (PIC)	006-5676	1
2	CNH interface cable	006-0890N	1
3	Communication harness	006-5650F	1

NOTES:

WARRANTY AND LIABILITY AGREEMENT

Harvest Tec, Inc. will repair or replace components that are found to be defective within 12 months from the date of manufacture. Under no circumstances does this warranty cover any components which in the opinion of Harvest Tec, Inc. have been subjected to negligent use, misuse, alteration, accident, or if repairs have been made with parts other than those manufactured and obtainable from Harvest Tec, Inc.

Our obligation under this warranty is limited to repairing or replacing free of charge to the original purchaser any part that in our judgment shows evidence of defective or improper workmanship, provided the part is returned to Harvest Tec, Inc. within 30 days of the failure. Parts must be returned through the selling dealer and distributor, transportation charges prepaid.

This warranty shall not be interpreted to render Harvest Tec, Inc. liable for injury or damages of any kind, direct, consequential, or contingent, to persons or property. Furthermore, this warranty does not extend to loss of crop, losses caused by delays or any expense prospective profits or for any other reason. Harvest Tec, Inc. shall not be liable for any recovery greater in amount than the cost or repair of defects in workmanship.

There are no warranties, either expressed or implied, of merchantability or fitness for particular purpose intended or fitness for any other reason.

This warranty cannot guarantee that existing conditions beyond the control of Harvest Tec, Inc. will not affect our ability to obtain materials or manufacture necessary replacement parts.

Harvest Tec, Inc. reserves the right to make design changes, improve design, or change specifications, at any time without any contingent obligation to purchasers of machines and parts previously sold.

Revised 01/03/06

HARVEST TEC, INC.
P.O. BOX 63
2821 HARVEY STREET
HUDSON, WI 54016
PHONE: 715-386-9100
1-800-635-7468
FAX: 715-381-1792
Email: info@harvesttec.com