

OWNER'S MANUAL

*Model 880
GPS Attachment*

HARVEST
TEC *Equipment and Products
for Quality Hay.™*

P.O. Box 63 • 2821 Harvey Street • Hudson, WI 54016
800-635-7468 • www.harvesttec.com

#010-0880

REVISED 4-10

HARVEST TEC 880 TABLE OF CONTENTS

	<u>PAGE</u>
INTRODUCTION	3
OVERVIEW	3
INSTALLATION OF GPS Receiver & Harness	4-7
INSTALLATION OF TRIMBLE AgGPS 162 RECEIVER	4
INSTALLATION OF GPS HARNESS	4
SYSTEM WIRING DIAGRAMS	4-5
HARVEST TEC SOFTWARE UPDATE INSTRUCTIONS	6-7
SETUP INSTRUCTIONS	8
YIELD MAPPING SETUP	8
OPERATING INSTRUCTIONS	9
PROCESSING YIELD DATA FILE	10-11
INSTALLATION OF YIELD FILE CONVERTER PROGRAM	10
CONVERTING YIELD DATA FILE	11
COMMON QUESTIONS ABOUT THE 880	12
TROUBLE SHOOTING CHECKS	12
PARTS BREAKDOWN FOR MODEL 880	13
NOTES	14
WARRANTY STATEMENT	BACK PAGE

*****Note: Need to Purchase Trimble 162
AgGPS*****

Case Pt. #: 87491749

New Holland Pt. #: 87491753

INTRODUCTION

Congratulations on purchasing a Harvest Tec Model 880 GPS attachment. The GPS harness will allow you attach the Trimble 162 AgGPS receiver (NOT included in 880 kit) to Harvest Tec's 500 moisture monitoring system or the 565 preservative applicator systems. By doing this it will allow you to collect important baling information to create yield files for each individual Job. If you already have Harvest Tec's Bale Identification System adding the GPS will also give you the ability to write exact coordinates to where a bale was tied in a field and apply that to its unique ID Tag. The model 880 will include the harness to connect the Trimble 162 receiver to your Harvest Tec 500/565 system, USB flash drive, PIP Removable Storage Cover, and Harvest Tec's yield mapping file converter program.

OVERVIEW

The Harvest Tec model 880 GPS gathers WAAS information on the fly and sends it to the PIP (Precision Information Processor) for processing. With this information the PIP creates a yield mapping file that will be stored onto the USB flash drive. This yield file, after being converted by Harvest Tec's yield mapping conversion program, can be useful to the user for present and future field management. The yield file is capable of being loaded into any type of field management software.

The field the yield file created will indicate where each bale was tied off. If you have Harvest Tec's Bale Identification System you will then have the ability to write that coordinate to the Tag and this will give you not only proof of what field the bale came from but also the approximate location of where the bale was made.

INSTALLATION OF GPS Receiver

Locate the Trimble AgGPS 162. The GPS receiver will be magnetically mounted on top of your baler in front of the misstie flag indicators or if they're not present on a flat surface near the knotter cover/door. This location should give the GPS receiver the best available location.

INSTALLATION OF GPS Harness

Locate the GPS harness (006-5650GPS). Attach harness to the GPS receiver and run harness to the right side of the baler. Using the zip ties provided, fasten the harness to the other 500 or 565 wiring harnesses. (**Note: make sure wiring harnesses are not in any pinch points and will not come in contact with moving parts on the baler.) For users that have Harvest Tec's Bale Identification System the GPS harness will be attached to the Tagger Control (to the port labeled Modular Port). For customers that do not have a Bale Identification System the Harness will be attached to the PIP (to the port labeled Tagger Control).

SYSTEM WIRING DIAGRAM

1. Connect the square plug end of the Harness to GPS receiver. Connect opposite end into one of the following:
 - a. Attach GPS harness to Tagger Control (Modular Port) if Bale Identification system is present. (Page 4)
 - b. If user doesn't have Bale Identification system and has a 500 or 565 system, attach GPS harness to PIP (Tagger Control Port). (Page 5)

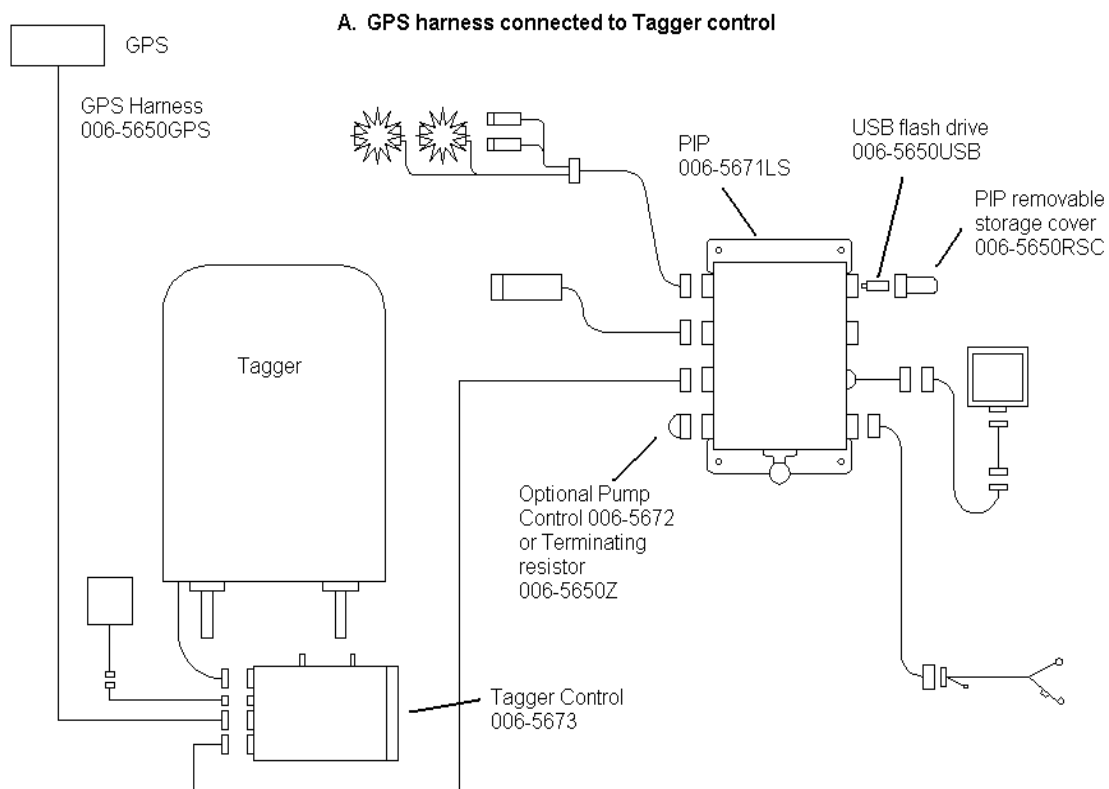

B. GPS harness connected to PIP

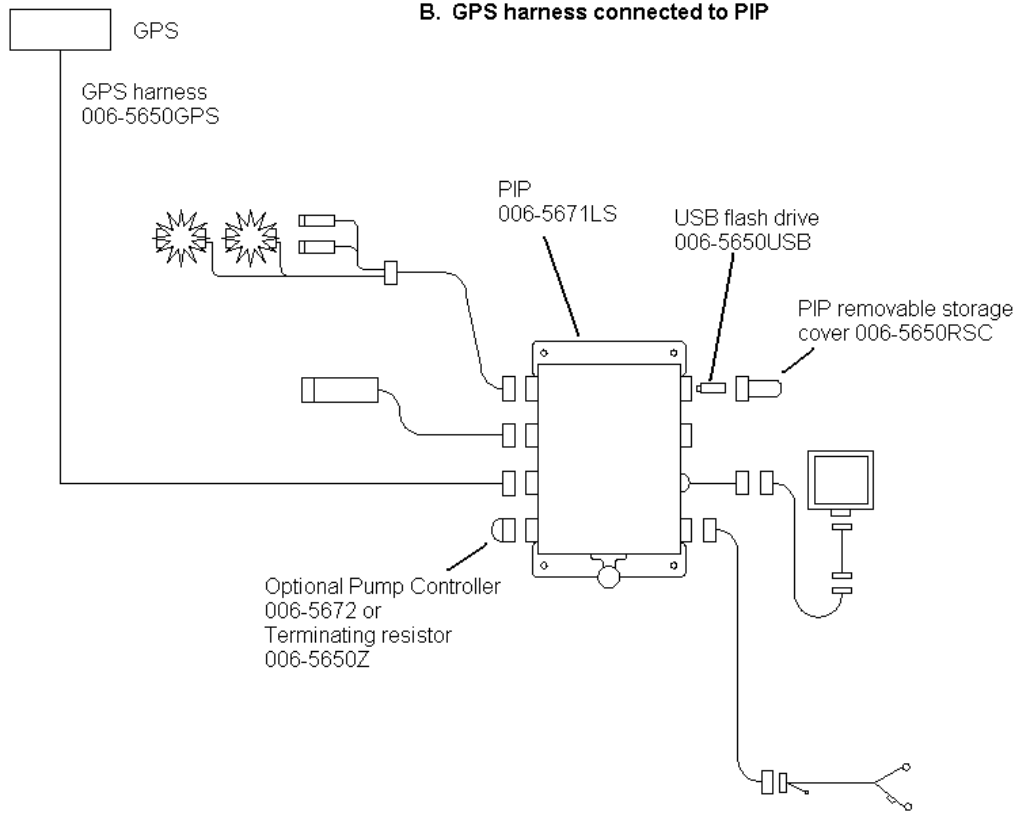

Harvest Tec 565 Software Updating Instructions

1. With the addition of the GPS attachment to the user's existing 500/565 system there will need to be a software update.
2. Start by downloading all of your existing Job Records off of your PIP (refer to 500, 565 or 596 manual for downloading instructions). **Once any software update is done to the 500/565 system all Job Records are erased.** Also, write down all important application/bale rate/tagger settings that you may want to reuse. These are returned to default once the update is complete.
3. All software files are on the USB flash drive included in the 880 GPS Attachment kit.
 - a. Insert your USB flash drive into the Data Transfer port on the PIP
4. Power the system on and the update will begin automatically. (**Note: **Do not power the system down or remove the USB flash during an update.**)
 - a. The PIP and display should beep once when powered on. The display should show 'Checking for Updates' for approximately 1 minute.
 - b. After the 1-2 minutes, the display should beep once and the display should change to 'Updating...' Depending on how much software needs to be changed, the screen may stay on the 'Updating...' screen for another minute. The display will flash every 2-3 seconds. It will continue to do this until the software is updated within the Display.
 - c. Once the display stops flashing, the software will need to finish configuring itself. It may take another 30 seconds to a minute for the update to take effect.
(**The whole software updating process should take 2-3 minutes)
5. Once the update process is complete, the 'Screen Calibration' layout will be displayed. Please recalibrate the screen to proceed to the main menu.
6. Once at the Main Menu screen, verify that in the bottom left-hand corner it displays **Version: 16050-56080.** (*****If the correct version numbers aren't displayed re-start update process beginning with step 2.)
7. Select the 'Setup Mode' button then find the 'PIP Setup' button on the lower left side. Press the 'PIP Setup' button to enter the 'PIP Setup' menu.
8. Once in the 'PIP Setup' screen, three item descriptions are displayed next to three mating numerical. For **Model** and **TSD Model** press the number next to it, re-enter that default value, press 'Enter' to confirm (ex: **Model: re-enter 5 and press enter to confirm**). For the **OEM** selection press the number related to you respective manufacturer and again press 'Enter' to confirm.

Model:	5
OEM:	
Harvest Tec	0
Agco	1
Case	2
New Holland	3
TSD Model:	4

9. If all three options are programmed correctly, the system will revert back to the main menu. Please verify that the 'PIP Setup' button that was in 'Setup Mode' has now disappeared.
10. Press 'Options' once screen is displayed press the **0** next to Flow Rate. It will then advance to another screen, Press **1** then press 'Enter' to confirm. The system will power down, **touch** the screen start the system again.
11. Once system reaches 'Main Menu' create a new Job and the system will be ready for setup (See 'Setup Instructions' on p. 8).

12. ******Remove USB FLASH DRIVE before system is turned off using key power ON****** If the system is restarted using key power it will go through the updating process once again resetting all of the users application parameters. Take the USB flash drive and insert it into the USB port on a computer. Open the USB flash drive and **delete** the files labeled as: tsd16050 (BIN file), pac01020 (BIN file), htp56080 (BIN file). ******DO NOT delete the file labeled ydConverterSetup-V1_0_0_0******

SETUP INSTRUCTIONS

1. Turn the 565 control system on. After a few seconds the Main Menu screen should appear. Press Setup Mode, the Setup Mode screen will then appear.
2. Press Yield Mapping setup.
 - a. Yield Mapping Setup should now be displayed.

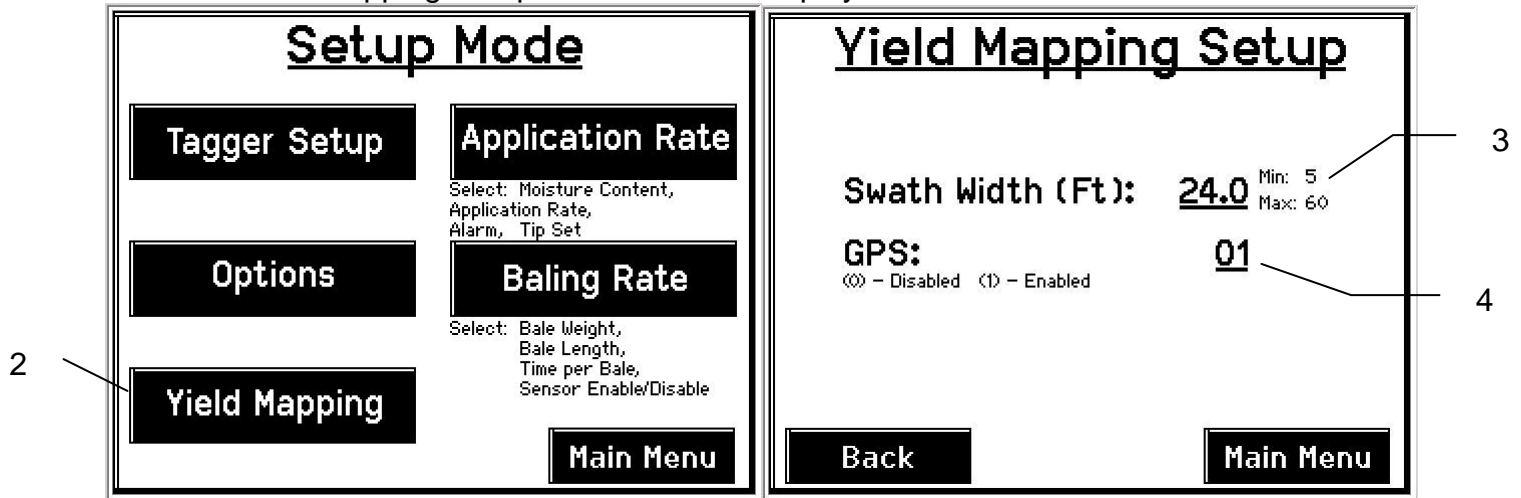

3. Press the underlined value next to **Swath Width (Ft)**. Enter in the swath width that will be baled, press **Enter** to confirm.
4. Press the underlined value next to **GPS**. Enabling/Disabling will require entering the appropriate value. 0 to Disable, 1 to Enable. Press **Enter** to confirm.
5. **Make sure the USB flash drive is inserted into the PIP's Data Transfer port before baling. Without the USB flash drive a yield file will not be created. (USB flash drive provided in the 880 kit)**



OPERATION INSTRUCTIONS

1. Once setup is complete the system is ready for baling. There is a GPS indicator icon that will appear in either of the Manual or Automatic mode screens. This icon shows the user that the GPS is transmitting data to the PIP to be processed. While all this is going on a Yield file is being created and saved to the USB flash.

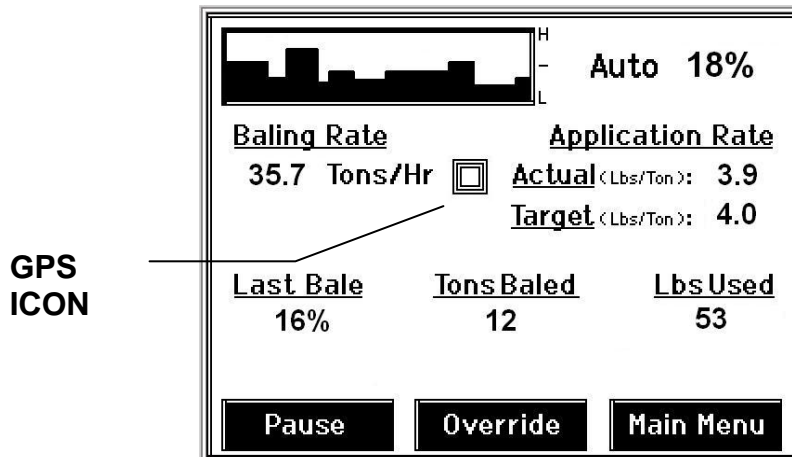

2. Once baling is complete, create a **New Job** and the yield data file will be complete and ready to be converted.

INSTALLATION OF YIELD DATA FILE CONVERTER PROGRAM

1. Plug the USB flash provided in the 880 kit into the USB port on the computer.
2. The USB flash will have a zipped file on it and will be labeled **ydConverterSetup-V1_0_0_0**.
 - a. Double click on that folder to open it and there will be two files inside labeled **setup** & **ydConverterSetup**. Double click on **ydConverterSetup**.

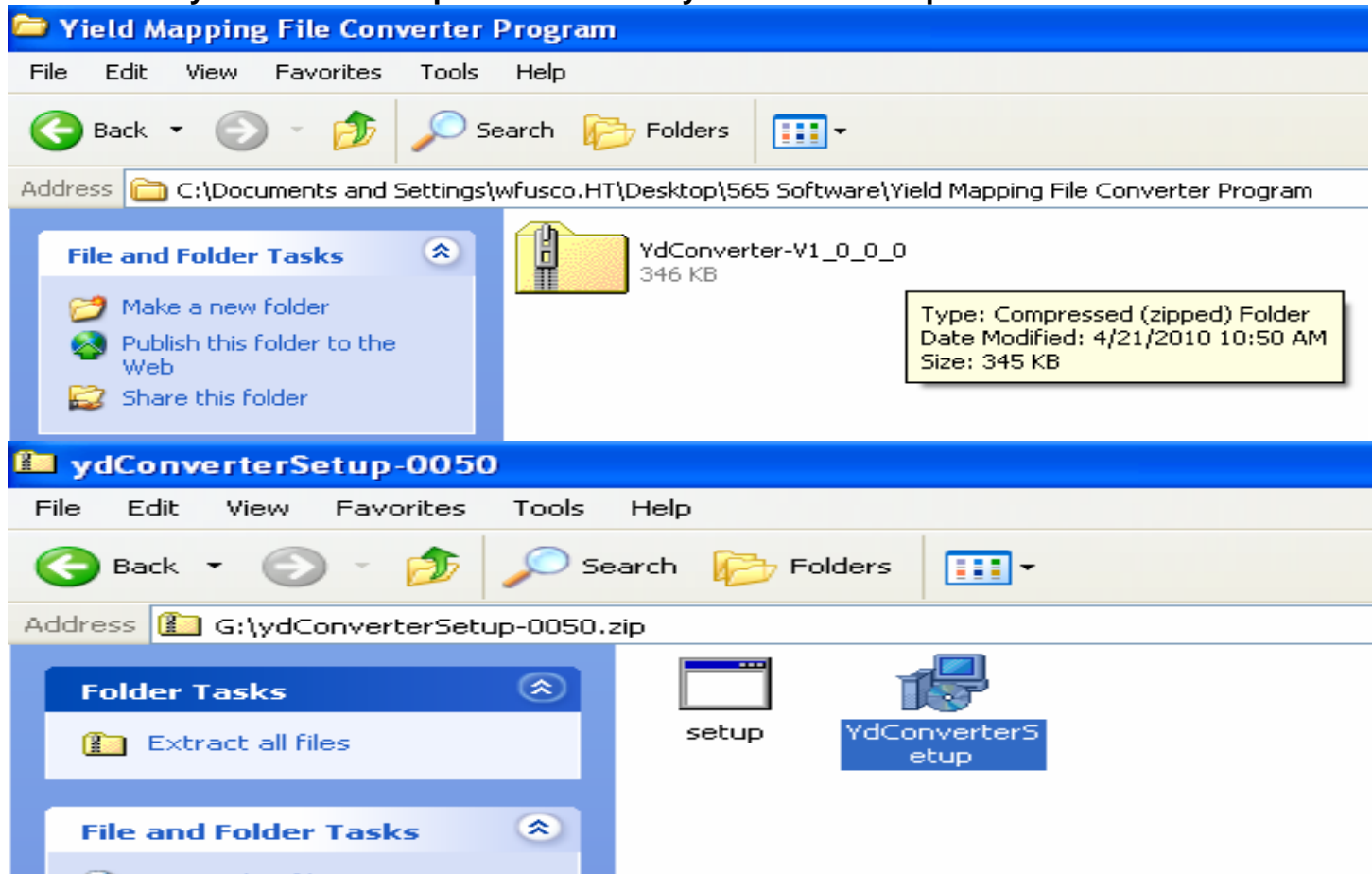

- b. A setup screen will appear, click **Next**.
- c. The next screen will ask you what folder you would like to save the File Converter Program in. Use the default option and click **Next** to accept. Next a confirmation screen will appear, press **Next** to confirm. The computer will then let the Yield File Converter Program install itself (Computer will take up to a 1 min to save the yield file converter program to its desktop).

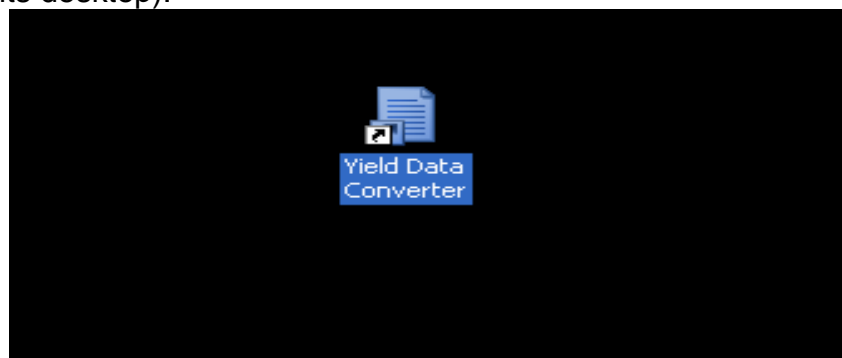

- d. Once the program has been installed you will see and Icon on the computers desktop as pictured above.

CONVERTING YIELD DATA FILE

1. The yield data file that was created on the USB flash while baling will need to be converted before it can be utilized in a yield mapping program. Start by double clicking on the yield mapping file converter Icon located on the computers desktop.
2. The program should open. Click on Select Files and navigate to the USB flash where the data files are located. Selected the file labeled as the users created job name **.YDT**



3. Once the **.YDT** file has been selected, click open to start the conversion. This process will take up to a few seconds. The converted file will read; the users created job name **-ym**. It will be located on the USB flash that the yield data file was created on.
- a. Once converted the file is in the appropriate format, it can be used by any yield mapping software/program.

COMMON QUESTIONS ABOUT THE 880

1. How do I verify that the yield file is being created?

Once you enter Automatic or Manual mode the message 'Opening USB Flash File' should appear. This indicates that the PIP is creating a yield file on the USB flash drive.

2. How many acres of yield mapping data can I get on my USB flash drive?

The USB flash drive provided has the ability to save 37,000 acres of yield information.

TROUBLE SHOOTING CHECKS:

PROBLEM	POSSIBLE CAUSE	SOLUTION
Message 'USB Flash not found' appears in Auto or Manual modes.	1. USB flash drive not in USB port on PIP.	1. Check to see if USB flash has fallen out or if one needs to be installed.
'Opening USB Flash File' is not appearing when entering Manual or Automatic mode.	1. GPS disabled.	1. Check Yield Mapping Setup to make sure that the GPS is enabled.

PARTS BREAKDOWN FOR MODEL 880



<u>Ref</u>	<u>Description</u>	<u>Part#</u>	<u>Qty</u>
1	PIP/GPS Harness	006-5650GPS	1
2	Removable Storage	006-5650USB	1
3	PIP Removable Storage Cover	006-5650RSC	1

NOTES:

WARRANTY AND LIABILITY AGREEMENT

Harvest Tec, Inc. will repair or replace components that are found to be defective within 12 months from the date of manufacture. Under no circumstances does this warranty cover any components which in the opinion of Harvest Tec, Inc. have been subjected to negligent use, misuse, alteration, accident, or if repairs have been made with parts other than those manufactured and obtainable from Harvest Tec, Inc.

Our obligation under this warranty is limited to repairing or replacing free of charge to the original purchaser any part that in our judgment shows evidence of defective or improper workmanship, provided the part is returned to Harvest Tec, Inc. within 30 days of the failure. Parts must be returned through the selling dealer and distributor, transportation charges prepaid.

This warranty shall not be interpreted to render Harvest Tec, Inc. liable for injury or damages of any kind, direct, consequential, or contingent, to persons or property. Furthermore, this warranty does not extend to loss of crop, losses caused by delays or any expense prospective profits or for any other reason. Harvest Tec, Inc. shall not be liable for any recovery greater in amount than the cost or repair of defects in workmanship.

There are no warranties, either expressed or implied, of merchantability or fitness for particular purpose intended or fitness for any other reason.

This warranty cannot guarantee that existing conditions beyond the control of Harvest Tec, Inc. will not affect our ability to obtain materials or manufacture necessary replacement parts.

Harvest Tec, Inc. reserves the right to make design changes, improve design, or change specifications, at any time without any contingent obligation to purchasers of machines and parts previously sold.

Revised 04/20/2010

HARVEST TEC, INC.
P.O. BOX 63
2821 HARVEY STREET
HUDSON, WI 54016
PHONE: 715-386-9100
1-800-635-7468
FAX: 715-381-1792
Email: info@harvesttec.com