

# OWNER'S MANUAL

## **Model 840** *Dye Sprayer Marking System*



---

P.O. Box 63 • 2821 Harvey Street • Hudson, WI 54016  
800-635-7468 • [www.harvesttec.com](http://www.harvesttec.com)

#010-0840  
**REVISED 2-10**

# HARVEST TEC 840 TABLE OF CONTENTS

|  | <b><u>PAGE</u></b> |
|--|--------------------|
| <b>INTRODUCTION &amp; TOOLS NEEDED</b>                     | <b>3</b>           |
| <b>INSTALLATION OF DYE SPAYER TANK &amp; PLUMBING</b>      | <b>4-10</b>        |
| 1. INSTALLATION OF MOUNTING BRACKET & TANK – LARGE SQUARES | 4                  |
| 2. INSTALLATION OF MOUNTING BRACKET & TANK – SMALL SQUARES | 5                  |
| 3. SYSTEM WIRING   | 6-7                |
| 4. INSTALLATION OF PLUMBING                                | 8-10               |
| ALL LARGE SQUARES  | 8-9                |
| ALL SMALL SQUARES (Conventional & Inline)                  | 8-9                |
| PLUMBING DIAGRAM   | 10                 |
| <b>FILLING TANK &amp; FIRST TIME &amp; ANNUAL START UP</b> | <b>11</b>          |
| 1. Filling the Tank  |                    |
| 2. First Time & Annual Start up                            |                    |
| <b>OPERATING INSTRUCTIONS AUTOMATIC OR MANUAL MODE</b>     | <b>12</b>          |
| <b>COMMON QUESTIONS ABOUT THE 840</b>                      | <b>13</b>          |
| <b>TROUBLE SHOOTING CHECKS</b>                             | <b>13</b>          |
| <b>MAINTENANCE</b>   | <b>13</b>          |
| <b>WIRING DIAGRAMS</b>                                     | <b>14</b>          |
| <b>PARTS BREAKDOWN</b>                                     | <b>15</b>          |
| <b>NOTES</b>   | <b>16</b>          |
| <b>WARRANTY</b>  | <b>17</b>          |
| <b>BACK PAGE</b>   | <b>18</b>          |

## **INTRODUCTION**

Congratulations on purchasing a Harvest Tec Model 840 Dye Sprayer Marking System. This system, after attached to a Model 565/562 Automatic Applicator or the Model 500 Moisture Monitor for any large/small square baler, will allow you to visibly mark the wet areas on your bales. The system includes the tank, pump, plumbing mounting hardware and necessary cables. If something goes wrong, bring this manual into the dealership so they can order the correct parts for you.

## **TOOLS NEEDED**

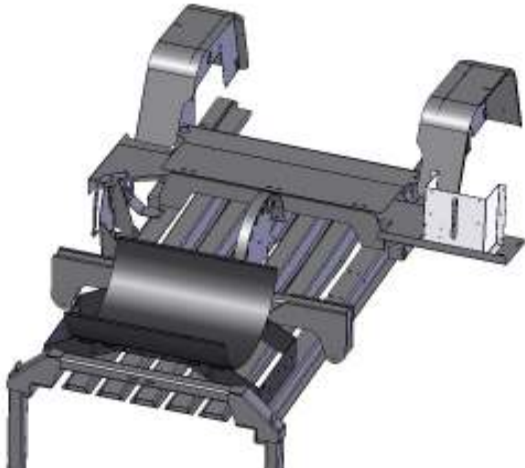
- Standard wrench set
- Standard socket set
- Hammer
- Metal drilling and cutting tools
- Center punch
- Tape measure
- Straight edge
- Marker

# INSTALLATION OF DYE SPAYER TANK & PLUMBING

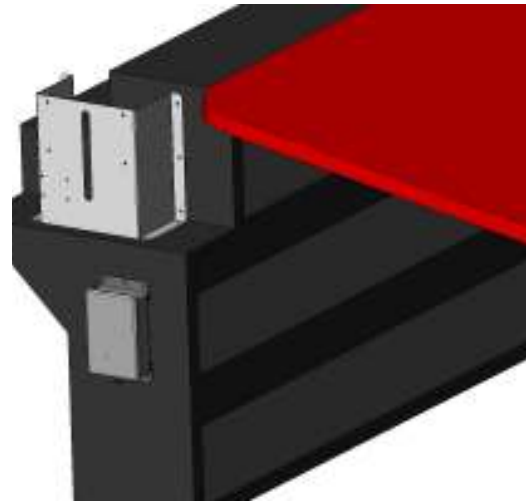
## 1. INSTALLATION OF MOUNTING BRACKET & TANK – LARGE SQUARES

Locate the tank and mounting bracket assembly. Looking at Figures 1, 2 & 3 decide which of these mounting locations will be the most convenient and work the best for the user.

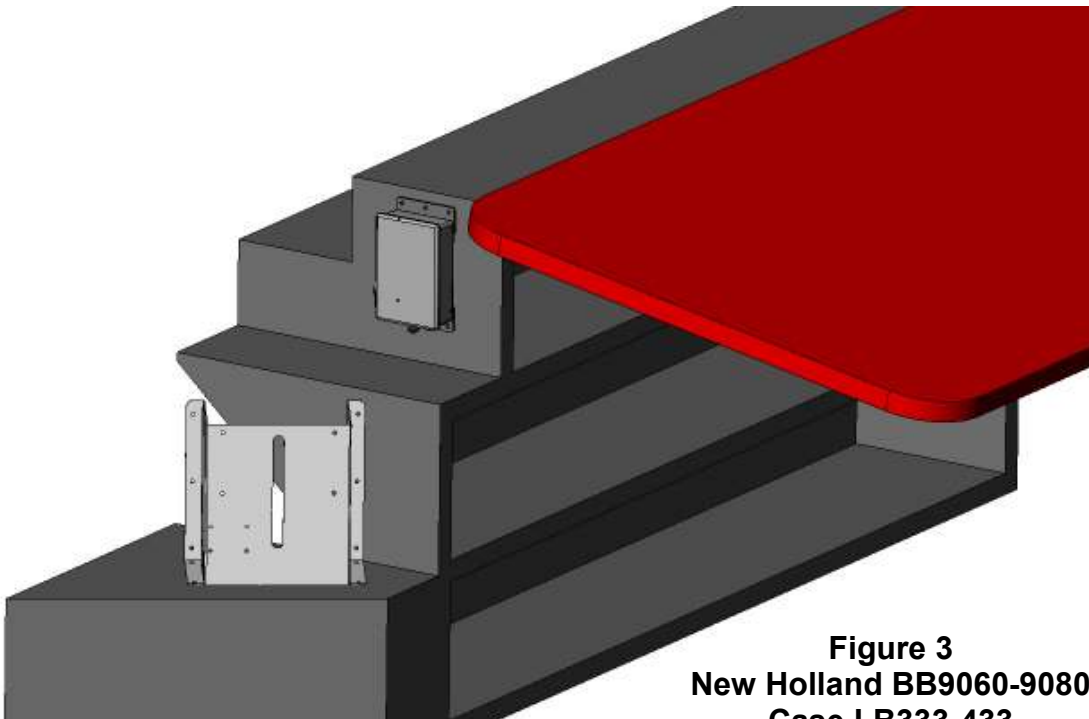
1. Once tank location is decided, mark the mounting holes and drill out using 3/8" bit.
2. Fasten the mounting bracket to the baler using the 5/16" hardware provided in the kit.



**Figure 1**  
Common Hesston, Massey  
Ferguson, Challenger Balers



**Figure 2**  
New Holland 590,595, BB940-960A  
Case LBX331-432

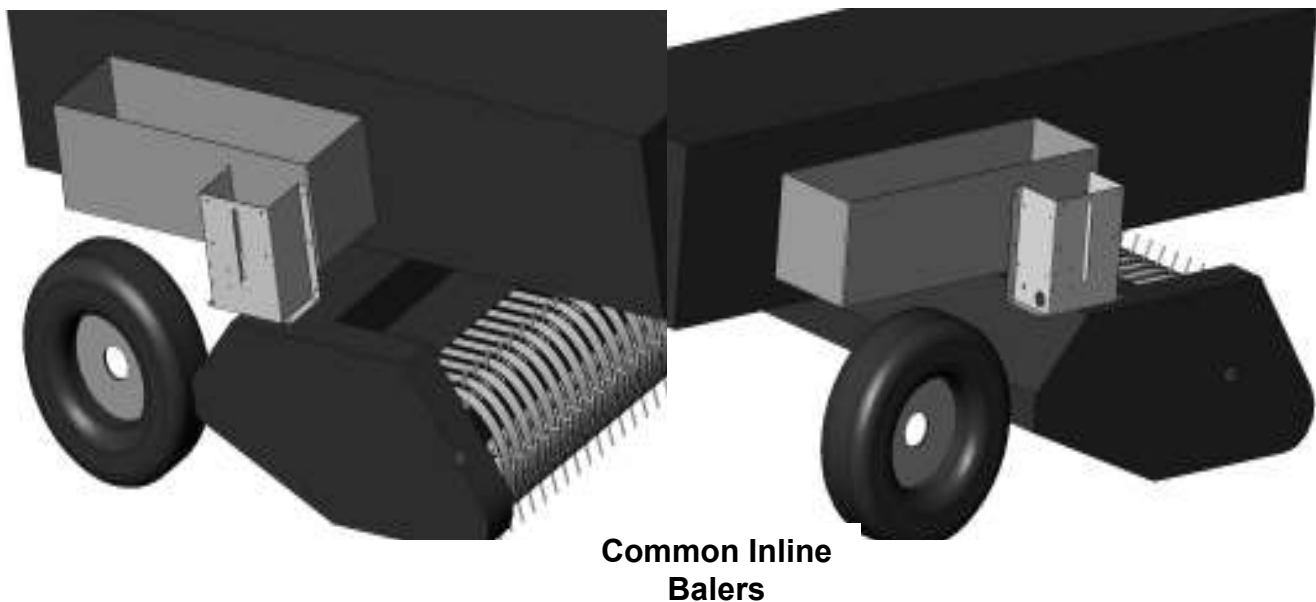
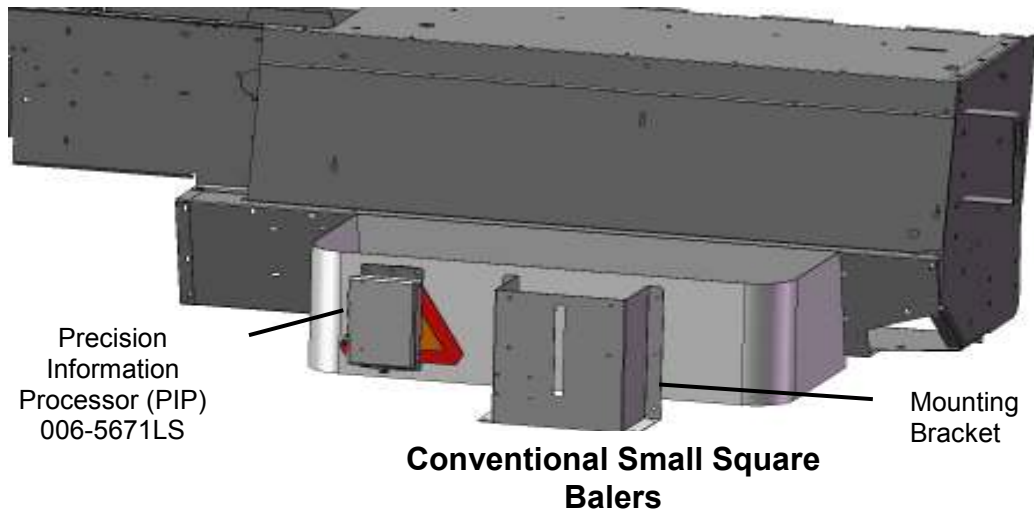


**Figure 3**  
New Holland BB9060-9080  
Case LB333-433

## 2. INSTALLATION OF MOUNTING BRACKET & TANK – SMALL SQUARES

Locate the tank and mounting bracket assembly. The tank and mounting bracket assembly will be mounted in one of the two locations pictured below. Based off of what is seen in the picture mount the assembly in the location that works best for the customer.

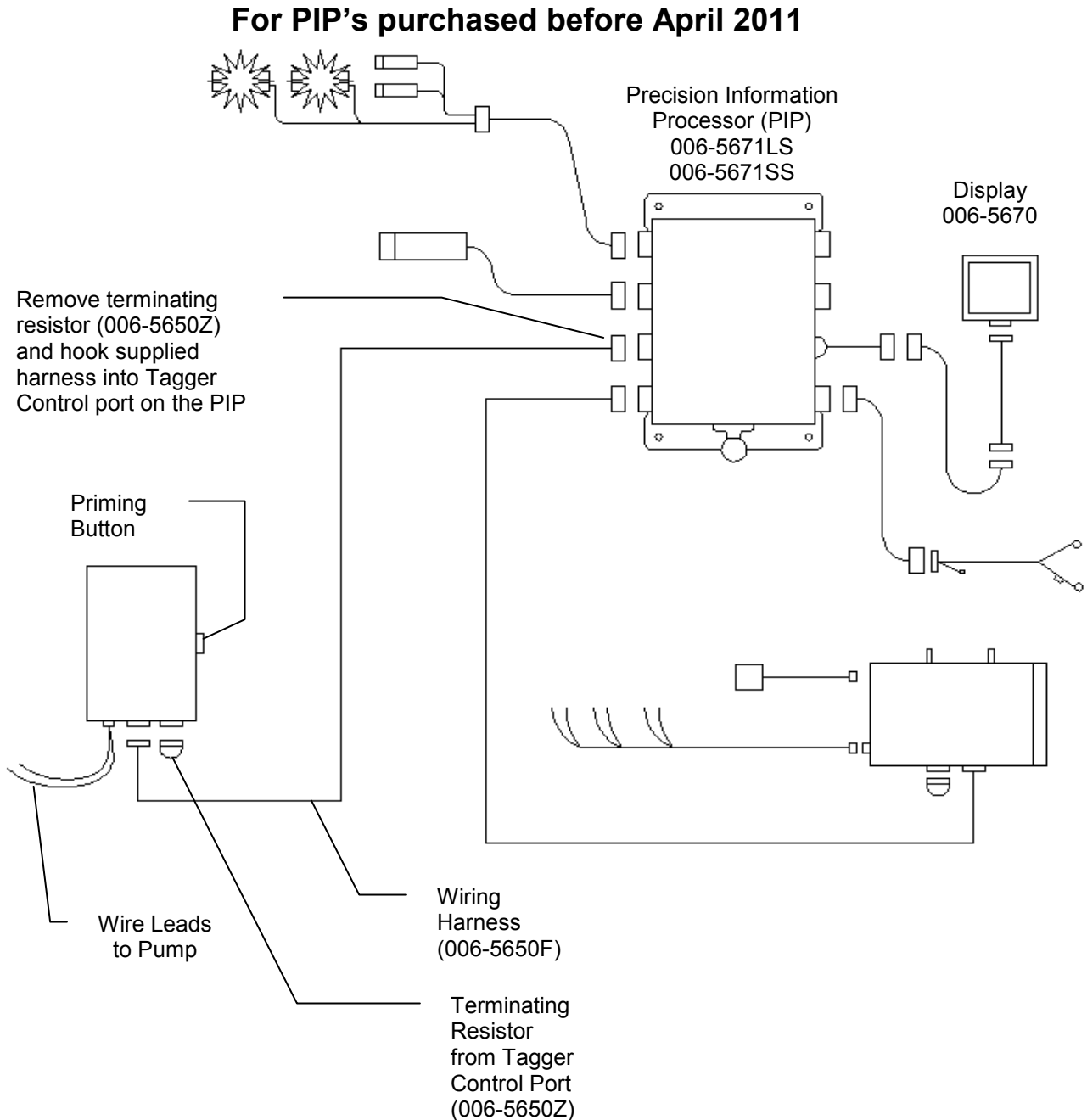
1. Start by aligning the tank mounting bracket on the twine box and mark each of the mounting holes.
2. Using a 3/8" drill bit, drill each of the marked holes and use the 5/16" x 1 1/4" bolts provided to mount the tank and bracket to the twine box.



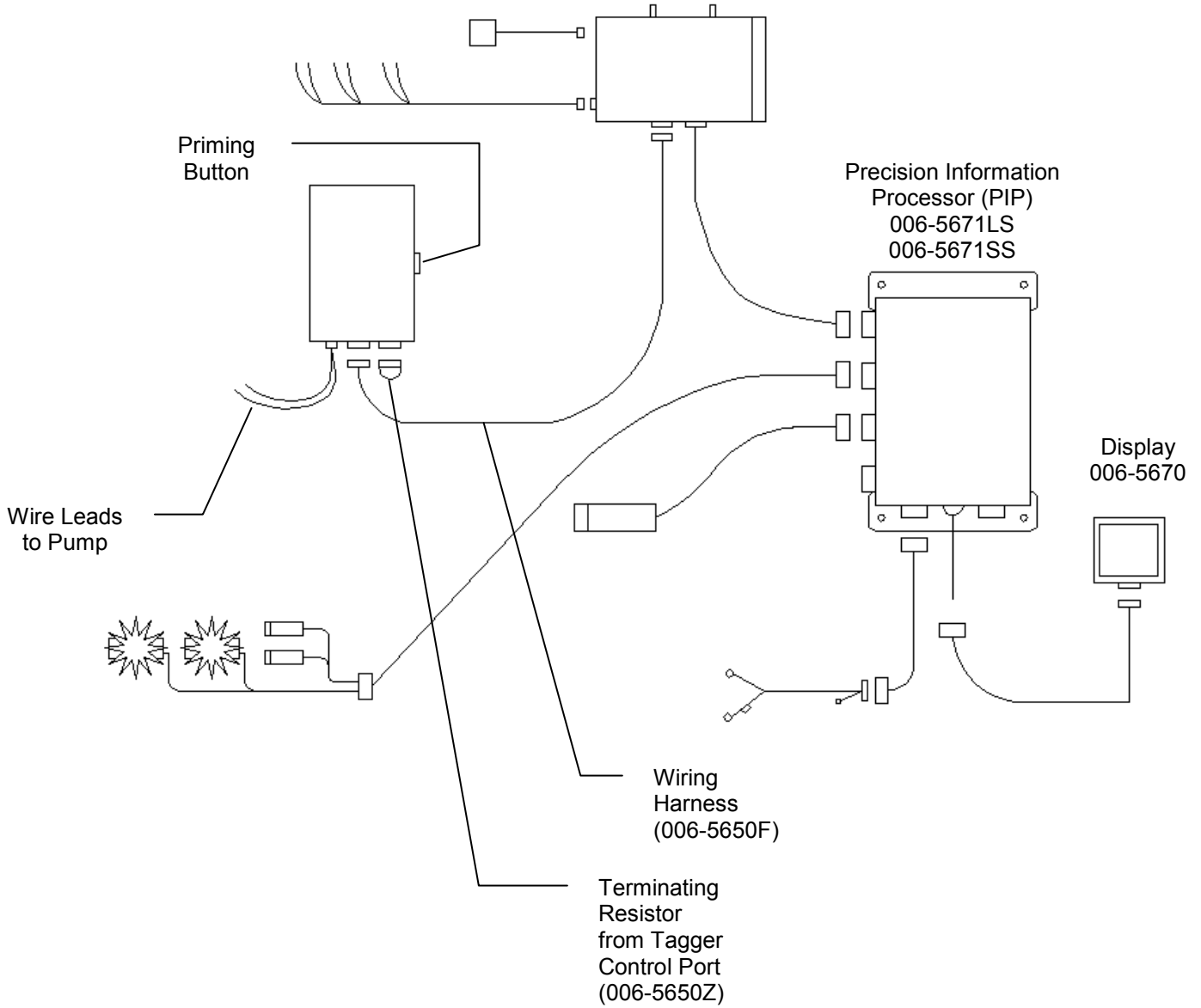
### 3. SYSTEM WIRING

Locate the wiring harness (006-5650F) supplied in the 840 Dye Sprayer Marking Kit. Connect one end of the DSM wire harness into the Tagger Control port located on the side of the Precision Information Processor (PIP). Route and fasten the remaining harness securely to the baler leading to the Dye Sprayer Module (DSM). Connect the wiring harness into the DSM as shown in the diagram below. Make sure the terminating resistor that was taken off of the PIP is fastened onto the modular port on the DSM.

**\*\*\*\*\*Make sure terminating resistor is on DSM\*\*\*\*\***



# For PIP's purchased after April 2011

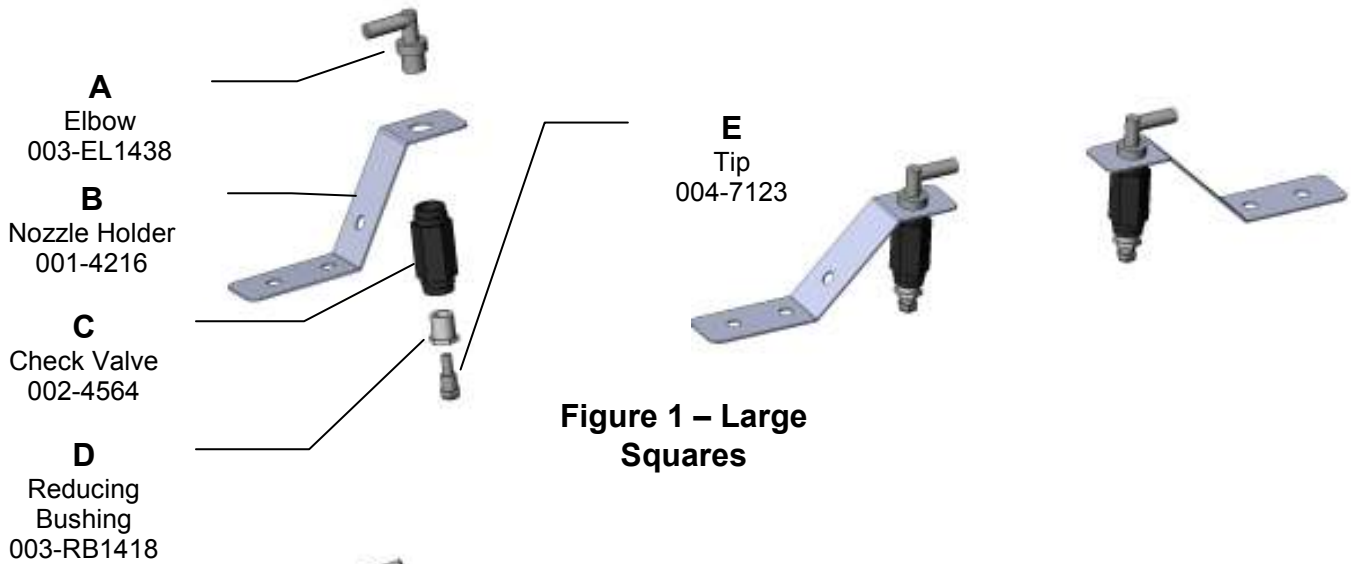


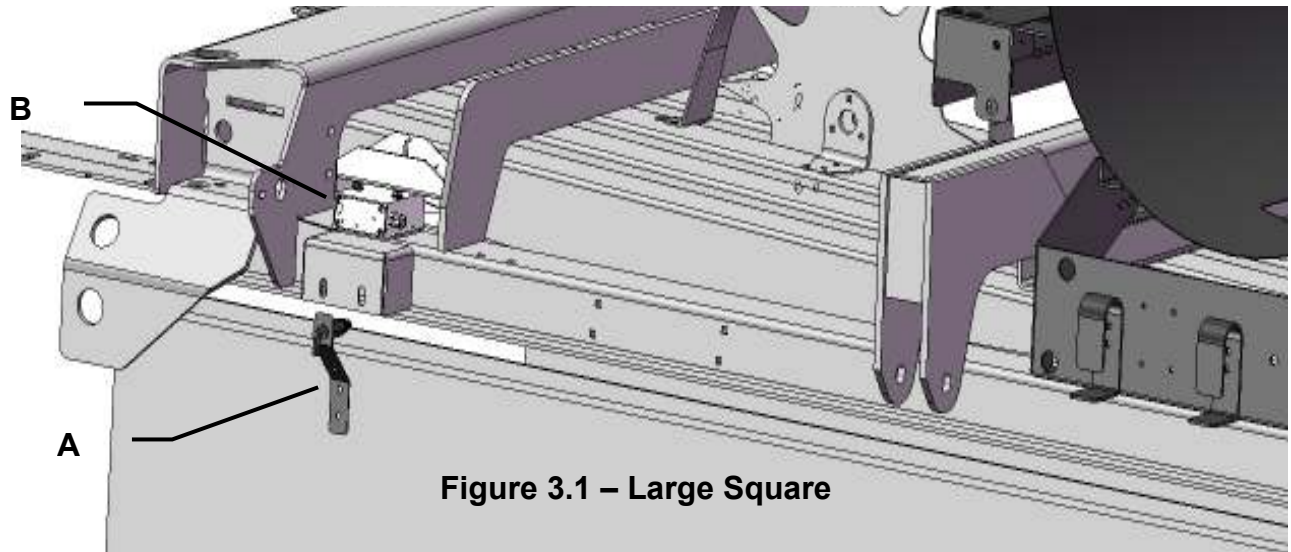
## INSTALLATION OF PLUMBING & WIRING

To most effectively mark the wet spots in any bale, Harvest Tec recommends that the nozzles are mounted directly above or below the Star Wheels. To get the best spray pattern focused directly on the wet spot of the bale the nozzles will need to be approximately 1" above the bale that is being marked. A small notch may need to be cut to increase surface area of the bale being marked.

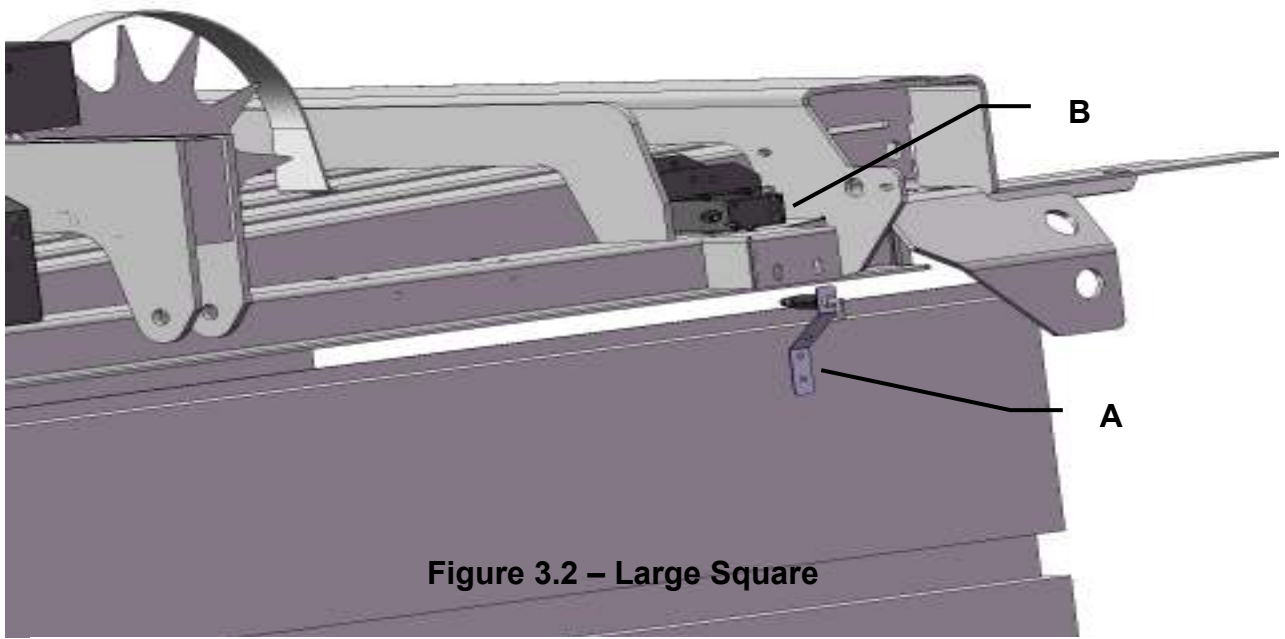
1. Once you have the tank and mounting bracket securely fastened to the baler, locate parts A, B, C, D & E pictured below in Figure 1 or 2. Assemble in the following order: (A)elbow/(B)nozzle holder/(C)check valve/(D)reducing bushing/(E)tip as pictured in Figures 1 or 2. (Figure 1- Large Squares; Figure 2 - Small Squares)  
**\*\*\*\*\*Note: All parts should be thread taped\*\*\*\*\***
2. Install the tip and nozzle holder assemblies in the suggested locations pictured below. Use the 1/4" hardware provided to do so. (Figure 3.1&3.2 - Large Squares; Figure 4 - Small Squares)
  - a. Make sure that the tip assemblies (A) are mounted in line with the star wheels (B) so that the system is marking the wet spots of the bale.
3. Once the nozzle holders are fastened to the balers, route the 3/8" hose to the tips. Make sure to fasten the hose securely but avoid pinching the lines. (Plumbing Diagram pictured in Figure 5)

**\*\*\*\*\*Keep from routing the hose in the way of moving parts on the baler\*\*\*\*\***

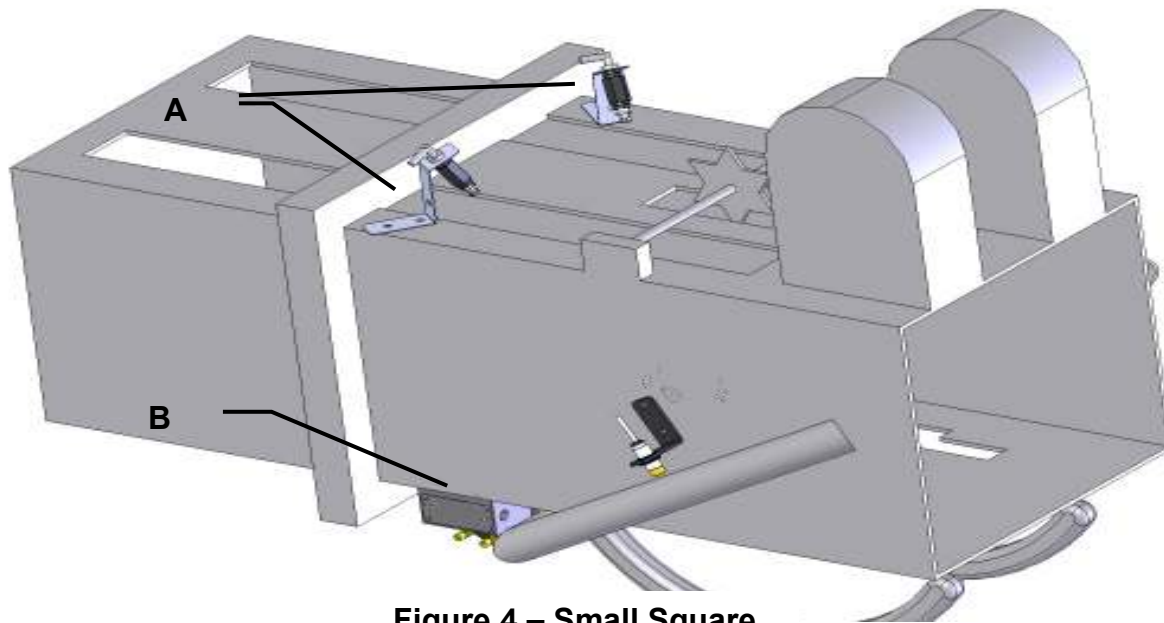




**Figure 3.1 – Large Square**

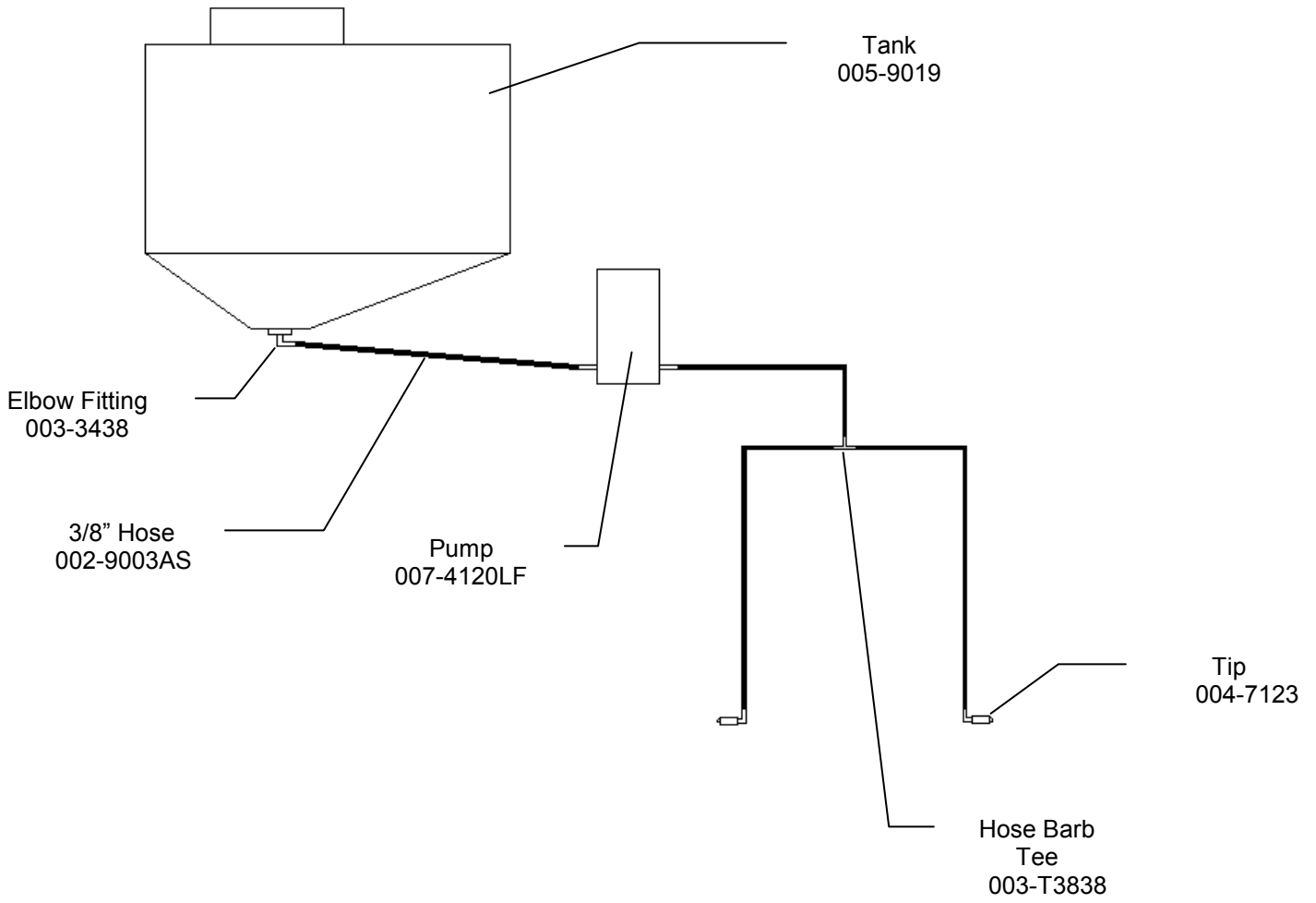


**Figure 3.2 – Large Square**



**Figure 4 – Small Square**

# Plumbing Diagram



**Figure 5**

## FILLING TANK & FIRST TIME AND ANNUAL START UP

### 1. FILLING THE TANK

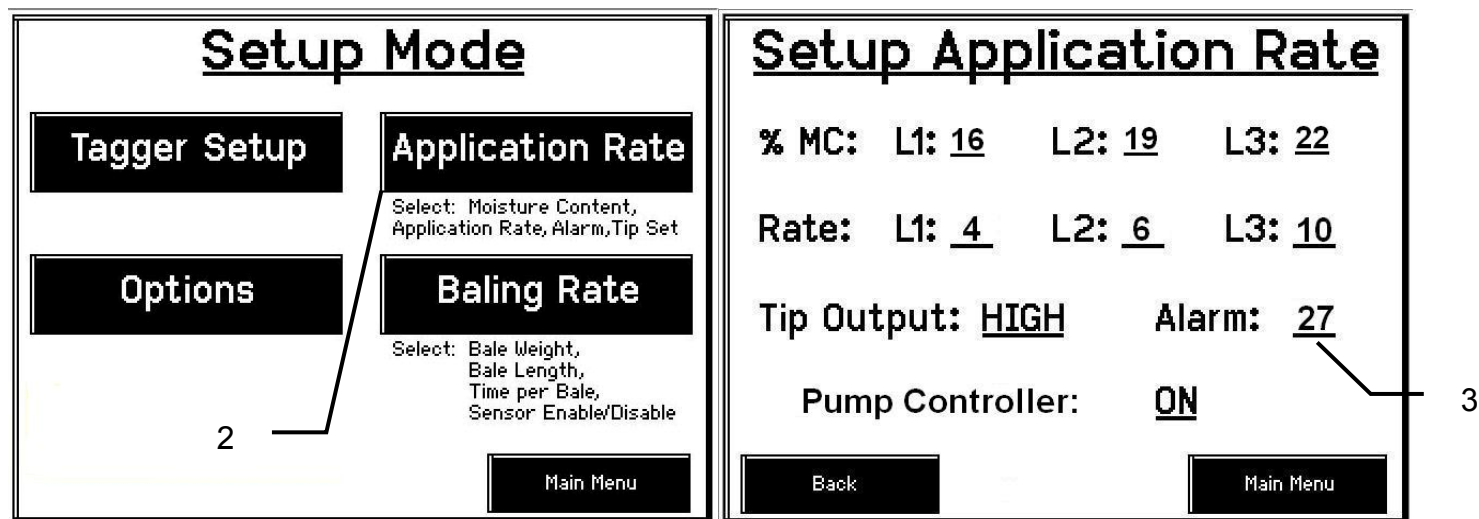
1. Remove the tank lid from the 3 gallon tank. Make sure the tank is clean and completely empty. Mix the Dye (009-0800) with warm water inside the Dye bottle. Make sure that the bottle is shaken vigorously so that the dye completely dissolves. Once the solution is mixed, add it to the 3 gallon tank and fill the tank with water.

### 2. FIRST TIME AND ANNUAL START UP

1. Once the tank has been filled the plumbing lines will need to be primed. Remove each of the two tips from the ends of the check valve bodies. Hold the priming button until all of the air is flushed out of the lines and there is a steady stream of liquid coming from each of the check valve bodies.

**\*\*\*NOTE: The system needs to be primed every time the system is run out of Dye\*\*\***

2. The Dye Sprayer Marker will always be active when it is attached to your 565, 562 applicators or 500 moisture monitoring system. You can adjust the moisture content level at which you would like the system to mark the 'Wet Flakes' in the bale being made. This can be done by entering 'Setup Mode' followed by 'Application Rate'.
3. Once you're in the 'Setup Application Rate' screen adjusting the Alarm level will adjust the Moisture Content level at which the Dye Sprayer will mark the bales.

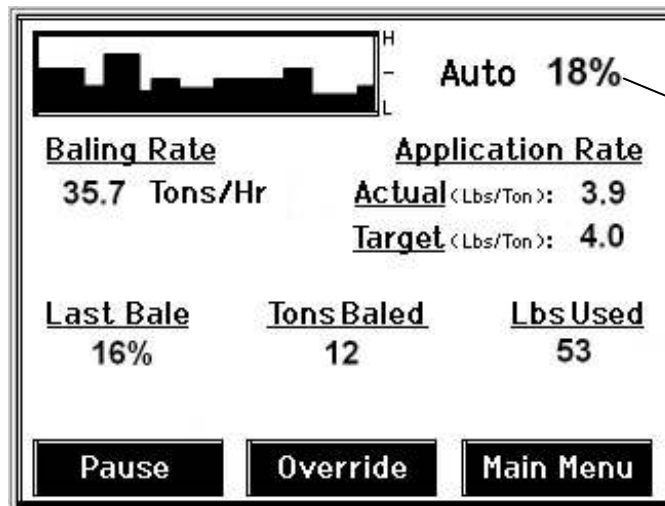


## OPERATING INSTRUCTIONS AUTOMATIC MODE OR MANUAL MODE

Auto & Manual mode will automatically mark bales with dye if the moisture content sensed by the star wheels is above the moisture 'Alarm' level that was set by the operator.

1. The moisture sensed by the star wheels is marked 1 in Figure 1 below. See page 9 for set-up instructions.

After pushing the AUTOMATIC MODE OR MANUAL MODE key in the Main Menu screen, the following screen should appear:



1

## **COMMON QUESTIONS ABOUT THE 840**

### **1. How do I set up the Alarm to begin marking Bales?**

To activate the Marking System from the 'Main Menu' screen enter the 'Setup Mode' screen. From there enter the Application Rate screen and adjust the moisture Alarm to the moisture content level at which you would like the system to mark your bales at.

### **2. Is the marking dye safe for livestock consumption?**

The DSM uses red-colored, food-grade dye and is safe for all livestock.

### **3. How do I bleed the air out of the lines properly?**

Remove the tips from the check valves that they're threaded into and press the button on the DSM until the air is pushed out of the lines.

## **TROUBLE SHOOTING CHECKS:**

| <b><u>Problem</u></b>         | <b><u>Possible Cause</u></b>   | <b><u>Solution</u></b>  |
|-------------------------------|--|---|
| The tips are not spraying Dye | <ol style="list-style-type: none"><li>1. The system is out of dye.</li><li>2. There is air in the lines, preventing a steady mist coming from the tips.</li><li>3. Damaged/pinched hose.</li><li>4. Tip is plugged.</li><li>5. Alarm is set too high</li></ol> | <ol style="list-style-type: none"><li>1. Check the tank for solution. If the tank is empty, refill and bleed air out of the lines.</li><li>2. Remove the tips from the check valves and using the priming button bleed the air out of the lines.</li><li>3. Inspect all the hose making sure the lines are damaged or pinched.</li><li>4. Removed the tip from the bushing and inspect, clean is necessary.</li><li>5. Lower the alarm level to the MC at with the user would like to have the bales marked at.</li></ol> |

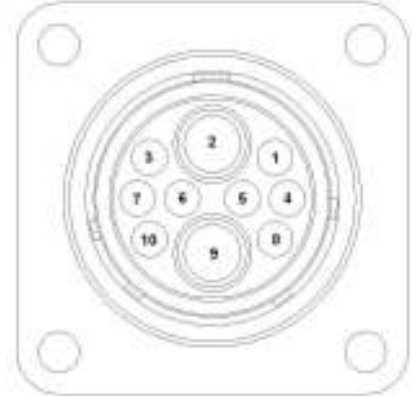
## **MAINTENANCE**

1. For **winter** storage, drain all of the liquid out of the lines and tank and pump.

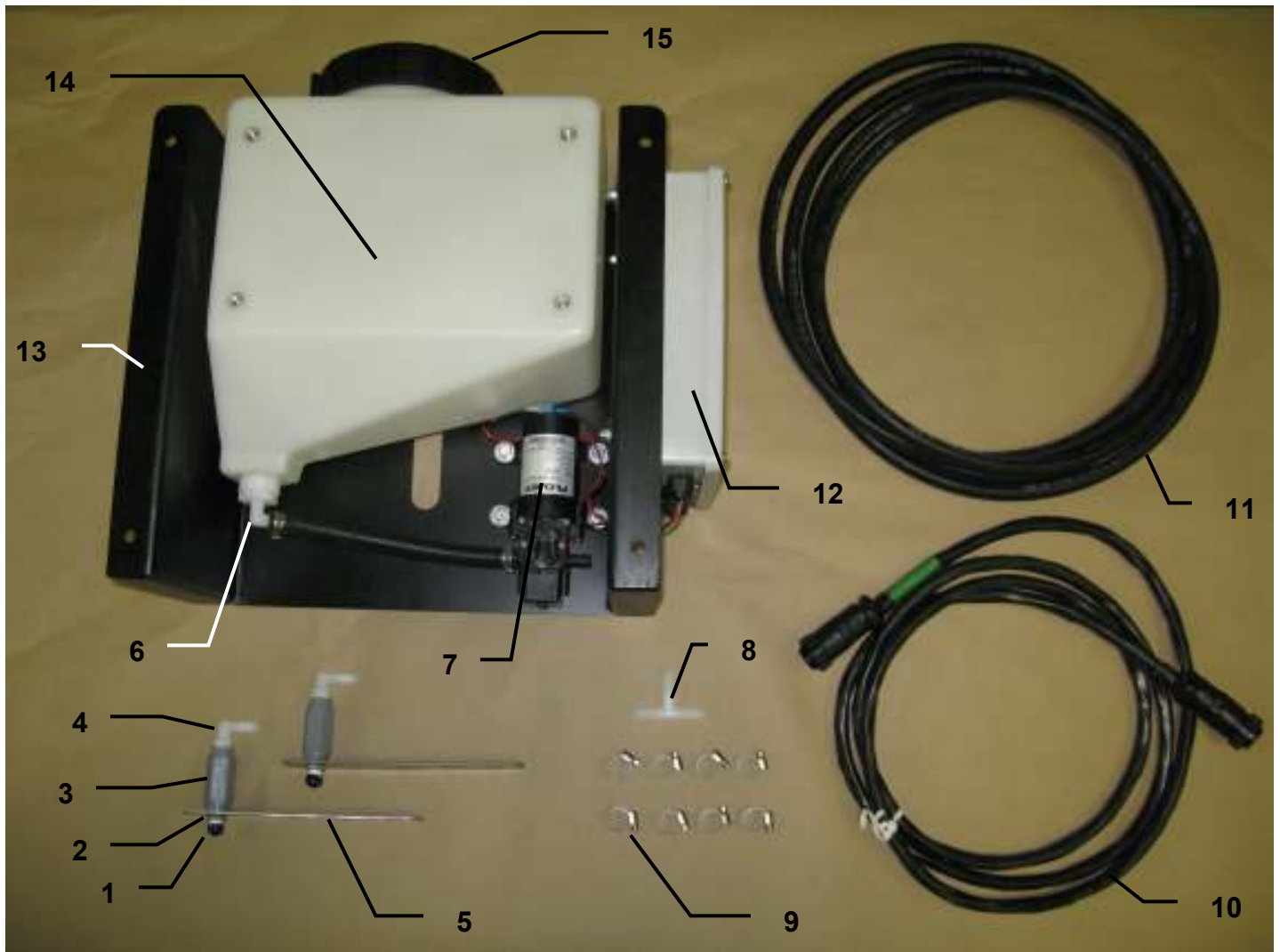
## WIRING DIAGRAM

### Communication harness on PIP and Dye Sprayer Module

|        |            |                    |
|--------|------------|--------------------|
| Pin 1  | Red        | Can 12 volt        |
| Pin 2  | Red 8 ga   | Battery 12 volt    |
| Pin 3  | Gray       | Shield             |
| Pin 4  | Green      | Can channel OH in  |
| Pin 5  | Yellow     | Can channel OL in  |
| Pin 6  | Blue       | Can channel OH out |
| Pin 7  | Orange     | Can channel OL out |
| Pin 8  | Black      | Can ground         |
| Pin 9  | Black 8 ga | Battery ground     |
| Pin 10 | Not used   |                    |



## Parts Breakdown for Model 840



| <u>Ref</u> | <u>Description</u>   | <u>Part#</u> | <u>Qty</u> |
|------------|----------------------|--------------|------------|
| 1          | Tip                  | 004-7123     | 2          |
| 2          | Reducing Bushing     | 003-RB1418   | 2          |
| 3          | Check Valve          | 002-4564F    | 2          |
| 4          | Elbow Fitting        | 003-EL1438   | 2          |
| 5          | Nozzle Holder        | 001-4216     | 2          |
| 6          | Elbow Fitting        | 003-EL3438   | 1          |
| 7          | DSM Pump             | 007-4120LF   | 1          |
| 8          | 3-Way Hose Barb Tee  | 003-T3838    | 1          |
| 9          | Hose Clamp           | 002-9002     | 8          |
| 10         | DSM Harness          | 006-5650F    | 1          |
| 11         | Rubber Hose          | 002-9003AS   | 15 ft      |
| 12         | Dye Sprayer Module   | 006-5677     | 1          |
| 13         | DSM Mounting Bracket | 001-2500     | 1          |
| 14         | Tank                 | 005-9019     | 1          |
| 15         | Tank Cap             | 005-9022C    | 1          |
| NP         | Tank Cap Gasket      | 005-9022CG   | 1          |

**Notes:**

## **WARRANTY AND LIABILITY AGREEMENT**

Harvest Tec, Inc. will repair or replace components that are found to be defective within 12 months from the date of manufacture. Under no circumstances does this warranty cover any components which in the opinion of Harvest Tec, Inc. have been subjected to negligent use, misuse, alteration, accident, or if repairs have been made with parts other than those manufactured and obtainable from Harvest Tec, Inc.

Our obligation under this warranty is limited to repairing or replacing free of charge to the original purchaser any part that in our judgment shows evidence of defective or improper workmanship, provided the part is returned to Harvest Tec, Inc. within 30 days of the failure. Parts must be returned through the selling dealer and distributor, transportation charges prepaid.

This warranty shall not be interpreted to render Harvest Tec, Inc. liable for injury or damages of any kind, direct, consequential, or contingent, to persons or property. Furthermore, this warranty does not extend to loss of crop, losses caused by delays or any expense prospective profits or for any other reason. Harvest Tec, Inc. shall not be liable for any recovery greater in amount than the cost or repair of defects in workmanship.

There are no warranties, either expressed or implied, of merchantability or fitness for particular purpose intended or fitness for any other reason.

This warranty cannot guarantee that existing conditions beyond the control of Harvest Tec, Inc. will not affect our ability to obtain materials or manufacture necessary replacement parts.

Harvest Tec, Inc. reserves the right to make design changes, improve design, or change specifications, at any time without any contingent obligation to purchasers of machines and parts previously sold.

Revised 01/03/06

**HARVEST TEC, INC.**  
**P.O. BOX 63**  
**2821 HARVEY STREET**  
**HUDSON, WI 54016**  
PHONE: 715-386-9100  
1-800-635-7468  
FAX: 715-381-1792  
Email: [info@harvesttec.com](mailto:info@harvesttec.com)