

# Supplement Manual

***596K & 565K supplement***  
***For Krone 12130 & HDP balers***

**HARVEST** *Equipment and Products*  
 **TEC** *for Quality Hay.™*

---

P.O. Box 63 • 2821 Harvey Street • Hudson, WI 54016  
800-635-7468 • [www.harvesttec.com](http://www.harvesttec.com)

#010-0596K  
**REVISED 10/10**

# SUPPLEMENT INDEX

	<u>PAGE</u>
INSTALLATION KIT REFERENCE CHART	3
INSTALLATION OF THE APPLICATOR	4-5
1. INSTALLATION OF PUMP PLATE	4
3. INSTALLATION OF TANK AND STAR WHEELS	5
PARTS BREAKDOWN	6
NOTES	7
WARRANTY AND LIABILITY	BACK PAGE

## INTRODUCTION

Use this supplemental manual with your 596 or 565 manual for installation instructions and parts breakdown.

## INSTALLATION KIT REFERENCE CHART

<b>BALER MAKE</b>	<b>BALER MODEL</b>	<b>INSTALLATION KIT</b>
Krone	1290 HDP w/cutter	4514B
Krone	12130 w/cutter	4514B
Krone	1290 HDP	4515B
Krone	12130	4515B

### Attention:

For kits on Krone HDP balers Krone part number 20 073 194 0 must be ordered to mount the starwheels.

## INSTALLATION OF APPLICATOR

### 1. INSTALLATION OF PUMP PLATE

#### FOR ALL KRONE 12130 & HDP BALERS

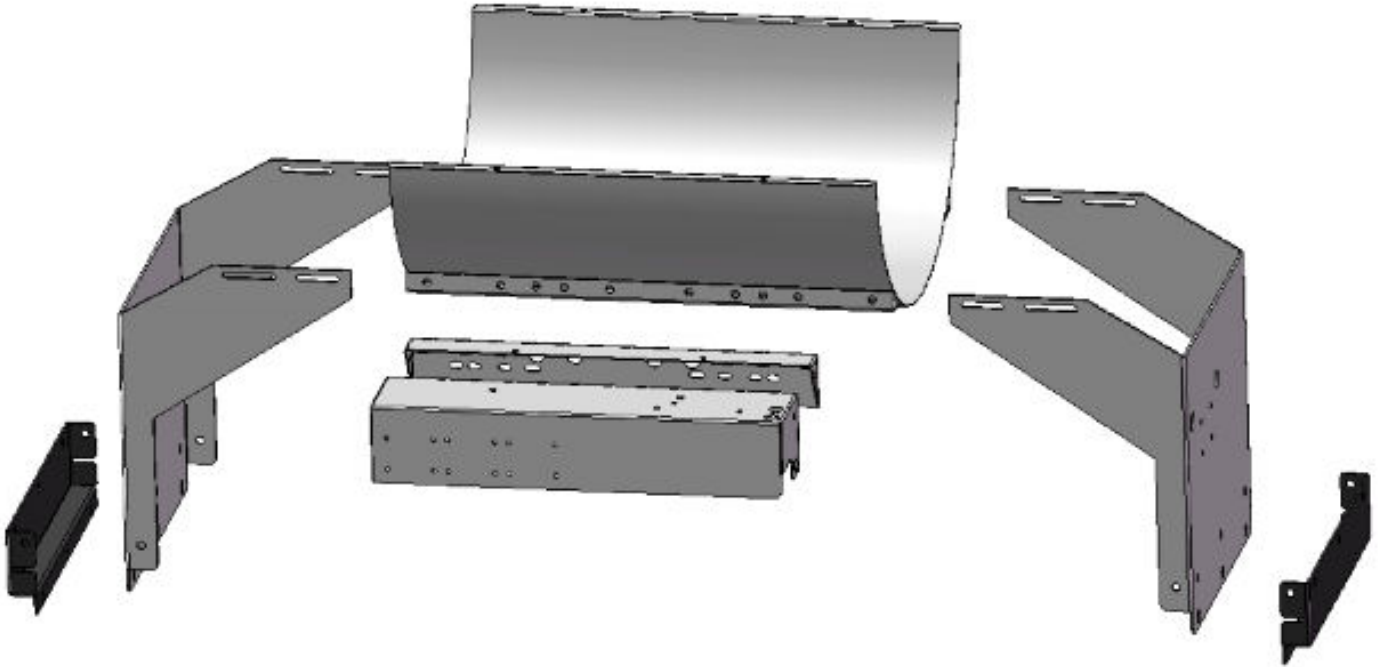

Install both saddle legs (001-6707KA) onto the saddle (001-6707A) with 3/8 x 1" Bolts, locks and flat washers. The mounting slots in the legs will attach to the first and second weld nuts in from each end, of the saddle, on both sides. Note: There is a "V" shape cut out in the sump area of the saddle. This side of the saddle should be attached to the side of the legs that have a narrower profile.

1. Once legs and saddle are loosely attached measure the distance from the top outside corners of the bale chamber where the saddle will be attached. Move legs in or out so the inside edges will match this dimension. Also try to center the saddle within these dimensions. Do not fully tighten down bolts until unit is mounted on the baler
2. Connect the pump plate mounting bracket (001-4646C) to the side of the saddle that has the wider profile to the legs. Note: you will have to remove the two inside bolts and replace them with two 3/8" x 1 1/4" bolts.
3. Attach the pump plate holder (001-4646D) to the pump plate mounting bracket (001-4646C) using four 3/8" x 3/4" flange head bolts

**The Pump Controller and pump heads must be pointing down. Failure to mount the pump plate assembly in this specified direction will void all warranty of the Pump Controller and pumps**

### 3. INSTALLATION OF TANK AND STARWHEELS

#### FOR ALL KRONE 2010 HDP BALERS

Mount the tank legs and saddle on the baler as shown below. You will need to drill 9/16" holes (3 per side) in the baler to bolt the leg adapters (001-6707KB). Use six 1/2 x 1 1/2 allen head carriage bolts, flats, locks, and nuts. The bolts should be inserted from inside the baler. The saddle legs (001-6707KA) will attach to the leg adapters using ten (5 per side) 1/2 x 1 1/2 bolts, locks, flats, and nuts.

The saddle is intentionally tipped forward by 5° so that the tank cap will be parallel to the ground. There is a small cut out "V" where the tank sump fits in the saddle and this cut out should face the back of the baler for the tank to be level when installed on the baler.

See Krone sheet 20 073 194 0 for star wheel mounting instructions.

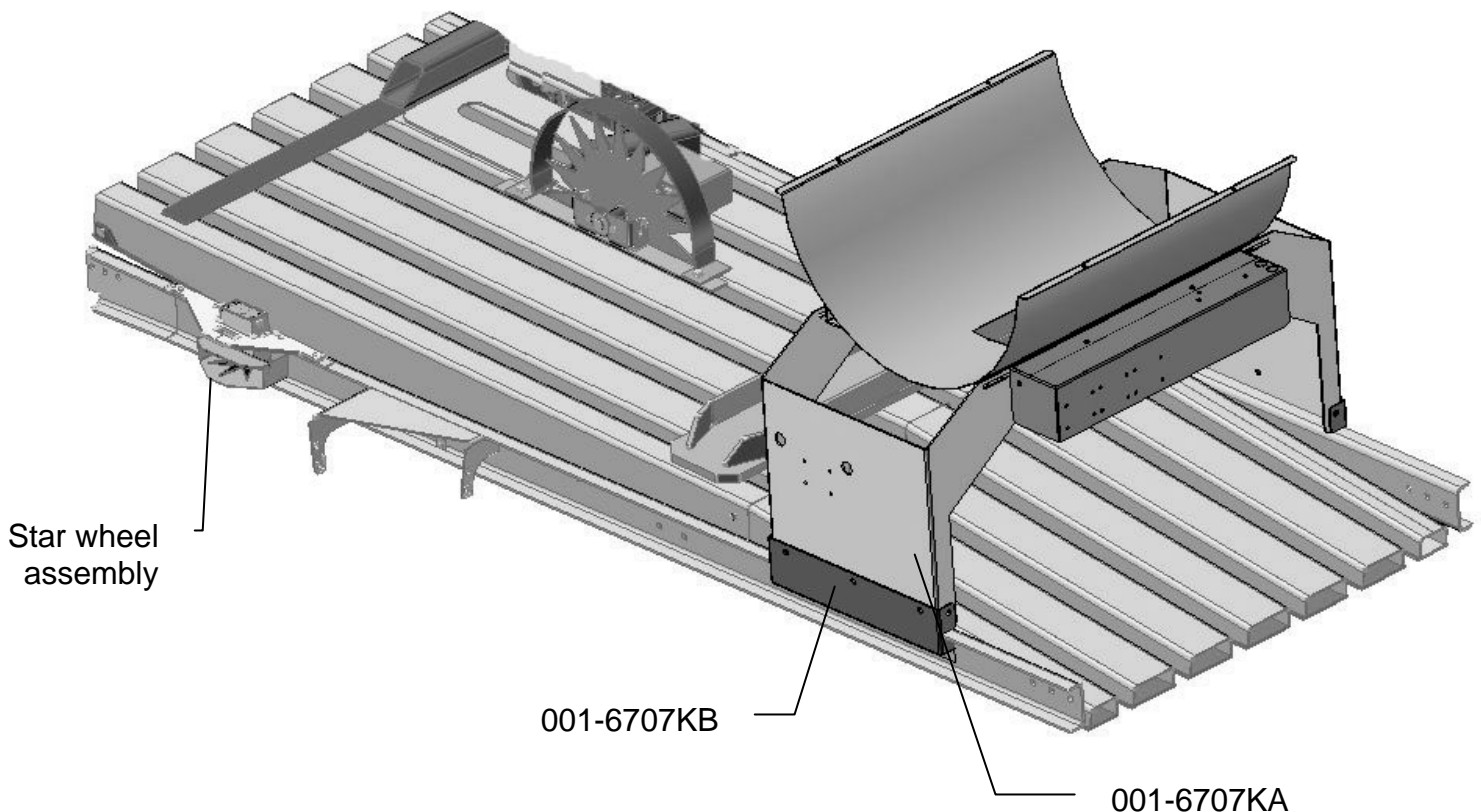

#### **For Pre-2010 HDP and 12130 balers**

Parts 001-6707KB are not used. Drill three 9/16" holes per side and mount with 1/2 x 1 1/2" allen head carriage bolts, flats, locks, and nuts.

Refer to 596 manual for mounting of starwheels on pre-2010 HDP & 12130 balers.

# TANK, SADDLE & LEGS PART #'S

Tank lid  
005-9022E

Tank straps  
001-4402B



Tank 110gl  
005-9208

Tank saddle  
001-6707A

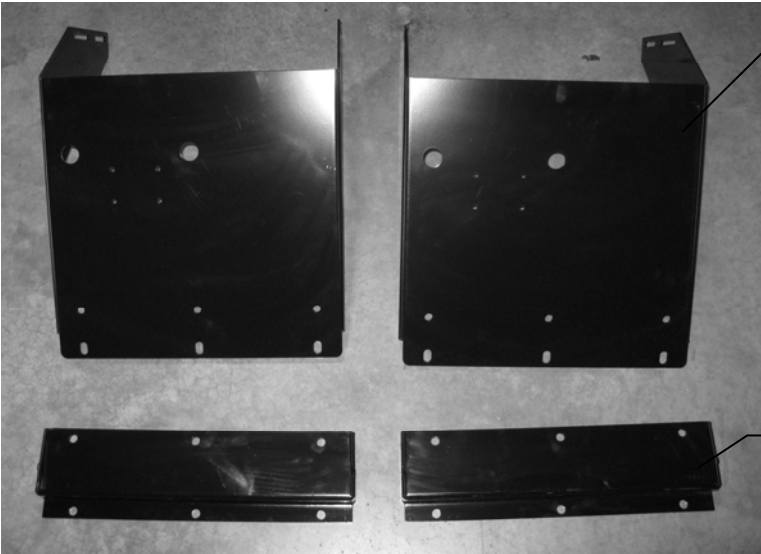

Saddle legs  
001-6707KA

Leg adapter  
001-6707KB

## NOTES:

## **WARRANTY AND LIABILITY AGREEMENT**

Harvest Tec, Inc. will repair or replace components that are found to be defective within 12 months from the date of manufacture. Under no circumstances does this warranty cover any components which in the opinion of Harvest Tec, Inc. have been subjected to negligent use, misuse, alteration, accident, or if repairs have been made with parts other than those manufactured and obtainable from Harvest Tec, Inc.

Our obligation under this warranty is limited to repairing or replacing free of charge to the original purchaser any part that in our judgment shows evidence of defective or improper workmanship, provided the part is returned to Harvest Tec, Inc. within 30 days of the failure. Parts must be returned through the selling dealer and distributor, transportation charges prepaid.

This warranty shall not be interpreted to render Harvest Tec, Inc. liable for injury or damages of any kind, direct, consequential, or contingent, to persons or property. Furthermore, this warranty does not extend to loss of crop, losses caused by delays or any expense prospective profits or for any other reason. Harvest Tec, Inc. shall not be liable for any recovery greater in amount than the cost or repair of defects in workmanship.

There are no warranties, either expressed or implied, of merchantability or fitness for particular purpose intended or fitness for any other reason.

This warranty cannot guarantee that existing conditions beyond the control of Harvest Tec, Inc. will not affect our ability to obtain materials or manufacture necessary replacement parts.

Harvest Tec, Inc. reserves the right to make design changes, improve design, or change specifications, at any time without any contingent obligation to purchasers of machines and parts previously sold.

Revised 01/03/06

**HARVEST TEC, INC.**  
**P.O. BOX 63**  
**2821 HARVEY STREET**  
**HUDSON, WI 54016**  
PHONE: 715-386-9100  
1-800-635-7468  
FAX: 715-381-1792  
Email: [info@harvesttec.com](mailto:info@harvesttec.com)