

Owner's Manual

500C1
Moisture only system for CNH balers

HARVEST *Equipment and Products*
 **TEC** *for Quality Hay.™*

P.O. Box 63 • 2821 Harvey Street • Hudson, WI 54016
800-635-7468 • www.harvesttec.com

#010-0500C1

REVISED 10/10

HARVEST TEC 500C1 TABLE OF CONTENTS

	<u>PAGE</u>
INTRODUCTION & TOOLS NEEDED FOR INSTALLATION	3
INSTALLATION OF SYSTEM	4-8
1. INSTALLATION OF PRECISION INFORMATION PROCESSOR	4
2. INSTALLATION OF STAR WHEELS	5
3. INSTALLATION OF STAR WHEEL WIRE HARNESS	6
4. WIRING INSTALLATION	7
SYSTEM WIRING DIAGRAM	7
5. MONITOR SETUP	8
PARTS BREAKDOWN	9
NOTES	10
WARRANTY AND LIABILITY	BACK PAGE

INTRODUCTION

The Harvest Tec model 500C1 is designed to read moisture on your baler monitor. The system will work with all monitors in CNH balers 2006 and newer (serial 4480 and above).

TOOLS NEEDED FOR INSTALLATION:

- Standard wrench set
- Electric drill and bits
- Side cutter
- Standard screwdriver
- Standard nut driver set
- Standard socket set
- Hammer
- Metal cutting tools
- Center punch

INSTALLATION OF SYSTEM

1. INSTALLATION PRECISION INFORMATION PROCESSOR

Follow the instructions below to mount the Precision Information Processor (PIP) onto your specific baler model and type. The locations shown are the right twine box (looking at the back of the baler). Mark and drill the four 3/8 holes and install PIP with four 5/16 x 1 bolts, locks, flats and nuts.

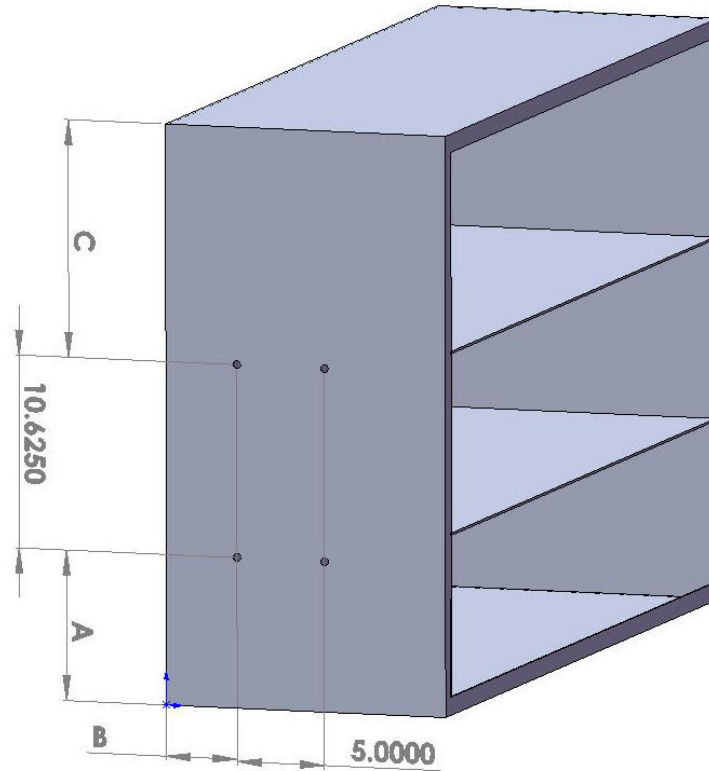

Baler Type	Model number	A	B	C
New Holland	BB940A -960A & BB9060-BB9080	N/A	2"	2"
Case IH	LBX 332-432 & LB 333 - 433	N/A	2"	2"

2. INSTALLATION STARWHEELS

The star wheels are to be mounted on top of the baler, just behind the knotters and under the walkway on both sides. Remove the bale from the chute, tip the walkway up and locate the wheels on the top outside corner angles of the bale chute, one on each side. Some balers may already have the notch cut and square holes. If so, the holes will need to be drilled round with a 5/16" drill bit. A 1/2" x 1/2" cut may also need to be made at the base of the twine arm mounting bracket for the star wheel to sit correctly on the bale chamber. Insert the four (per side) 5/16" x 3" black allen head bolts up through the chute and use nuts to hold the bolts in place. Place the star wheel block over the nuts and install the twine guards using the two inner holes of the star wheel block. See Step 3 for directions on how to hook-up the star wheel wires.

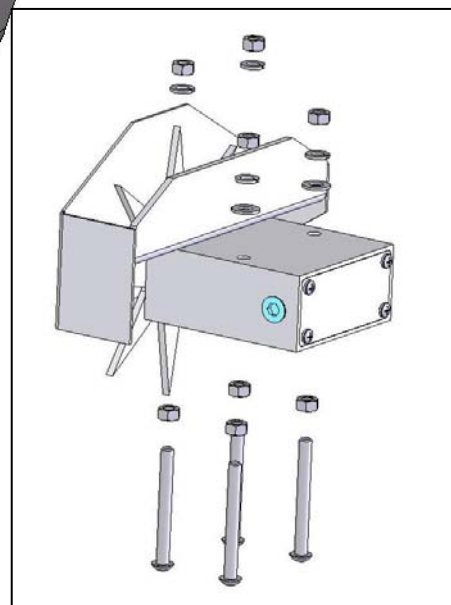
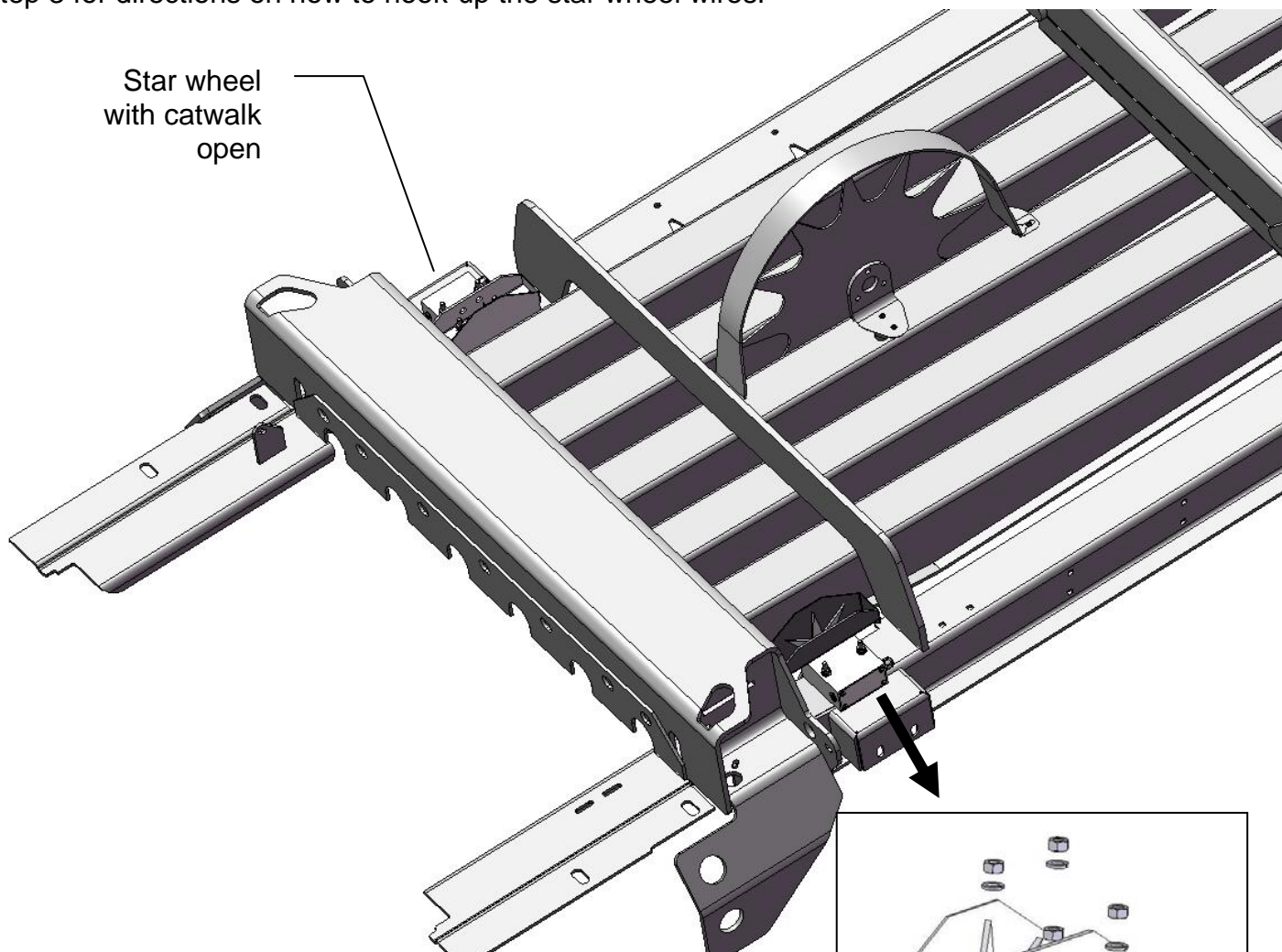

3. INSTALLATION OF STAR WHEEL WIRING HARNESS

First, remove the cover from the star wheel block and use a ¼" nut driver to remove the nut from the electronic swivel. Next, run the star wheel sensor wire (006-4640E2) through the black grommet and place the eye terminal on the star wheel sensor. Tighten the eye loop with the nut on the sensor and put the star wheel cover back on the base. Next, tighten the grommet to form a tight seal around the wire.

Once the star wheel connection is complete, run the harness along the baler frame to the Precision Information Processor (PIP). (See wiring installation on the following page.) The Precision Information Processor is located on the back of the right twine box.

006-4640E2

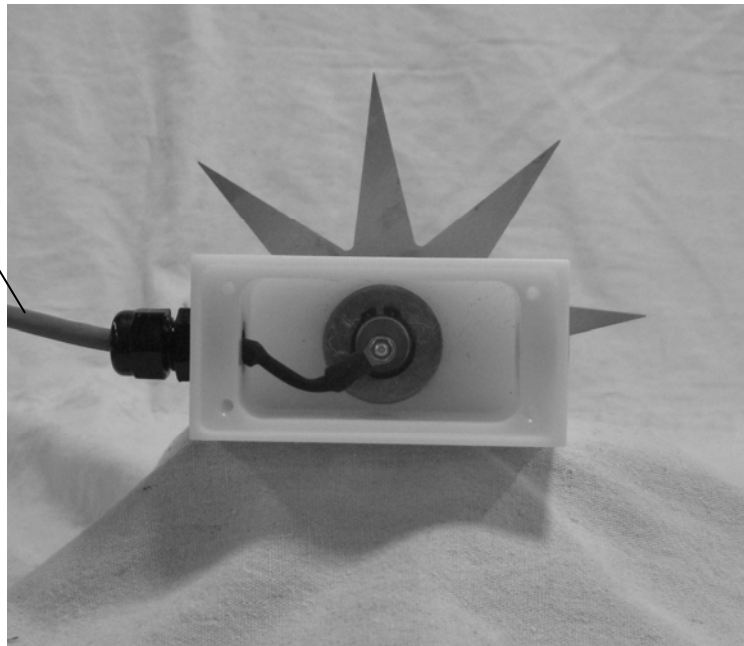

4. WIRING INSTALLATION

1. Connect the power and can comm. harness to PIP (006-5650I) at the display & power ports.
2. Connect harness (006-5650I) to connection on right side of baler. (Figure 2)
3. Connect star wheel harness 006-4640E2 at moisture & bale rate sensor port.
4. Install the two terminating resistors (006-5650Z & 006-4640J).

SYSTEM WIRING DIAGRAM

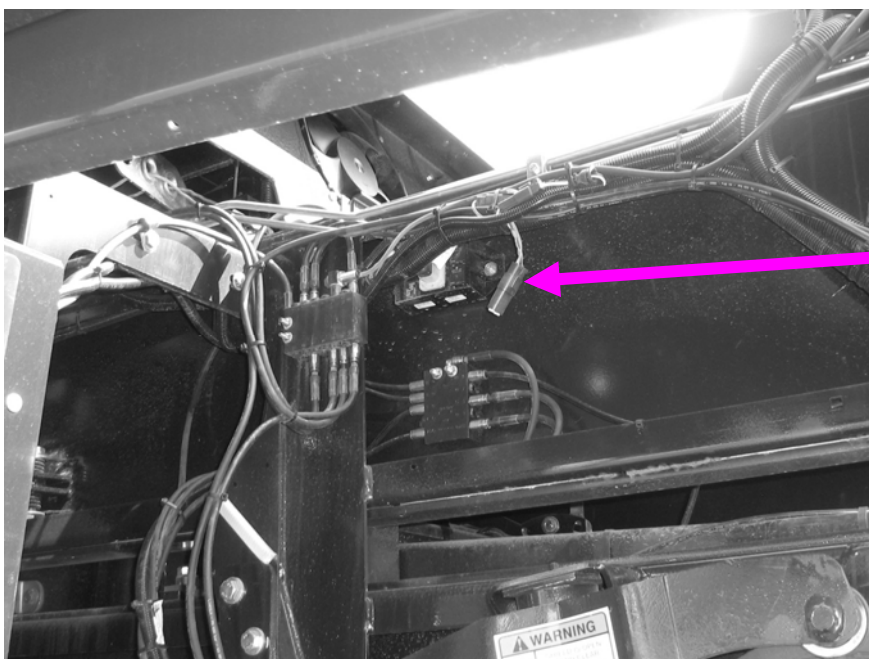
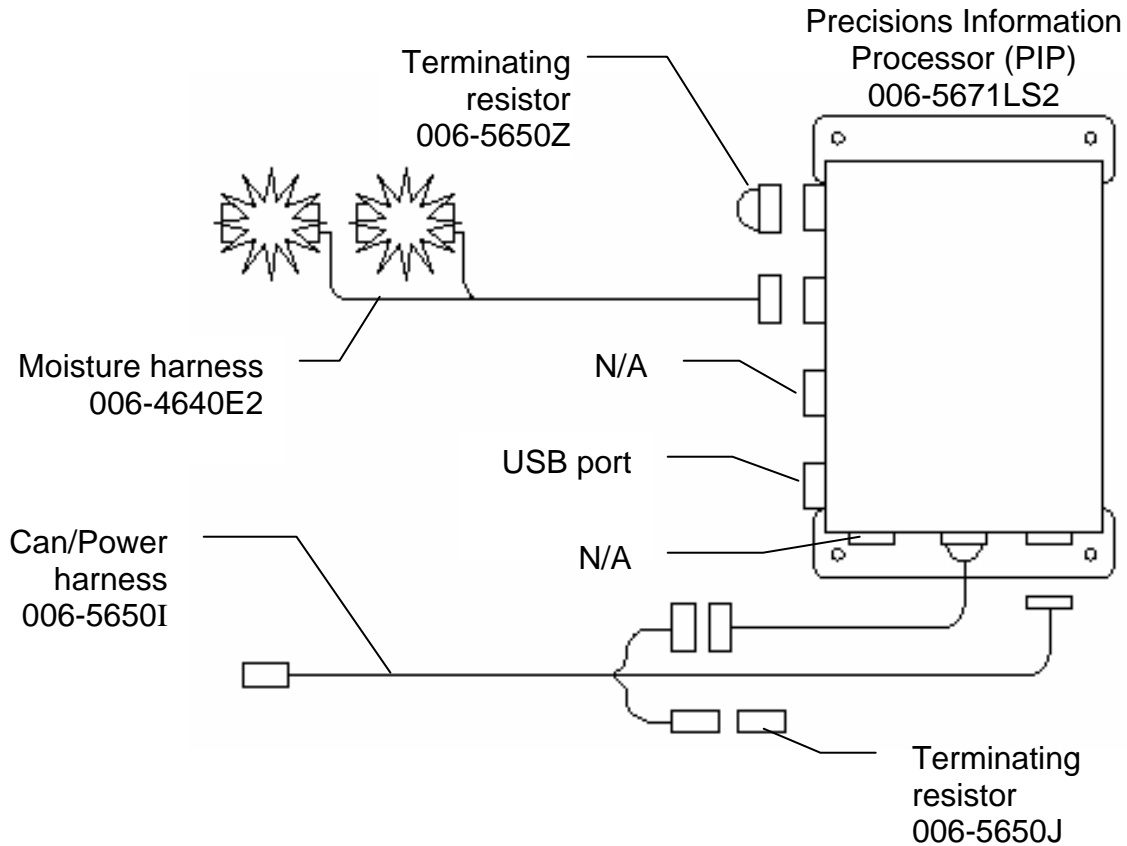

Figure 2

5. MONITOR SETUP

Open cover on the fuse/relay box on the right side of baler. Insert fuse into position F5. Refer to owners manual for additional help.

For machines with VT terminals

1. Select "Machine Setup" in you monitor and go into dealer mode.
2. Select "Not installed" from the "Moisture" sub-list in the machine setup list.
3. Select "Installed".
4. Leave dealer mode by switching the monitor "OFF" and back "ON".
5. Adjust the "Screen setup" in the monitor to view the "Bale moisture" and/or the "General environmental moisture" information.

Refer to the Service Manual of your machine for additional help.

For machines without VT terminals

1. In the sub-menu "Machine Setup" of the "Service Mode" select "Moisture Sensor" and change from "Not Installed" to "Installed"
2. In the sub-menu "Screen Setup" of the "Service Mode" adjust the view to see the "Moisture" information in the InfoView monitor.

Refer to the Service Manual for additional help.

PARTS BREAKDOWN

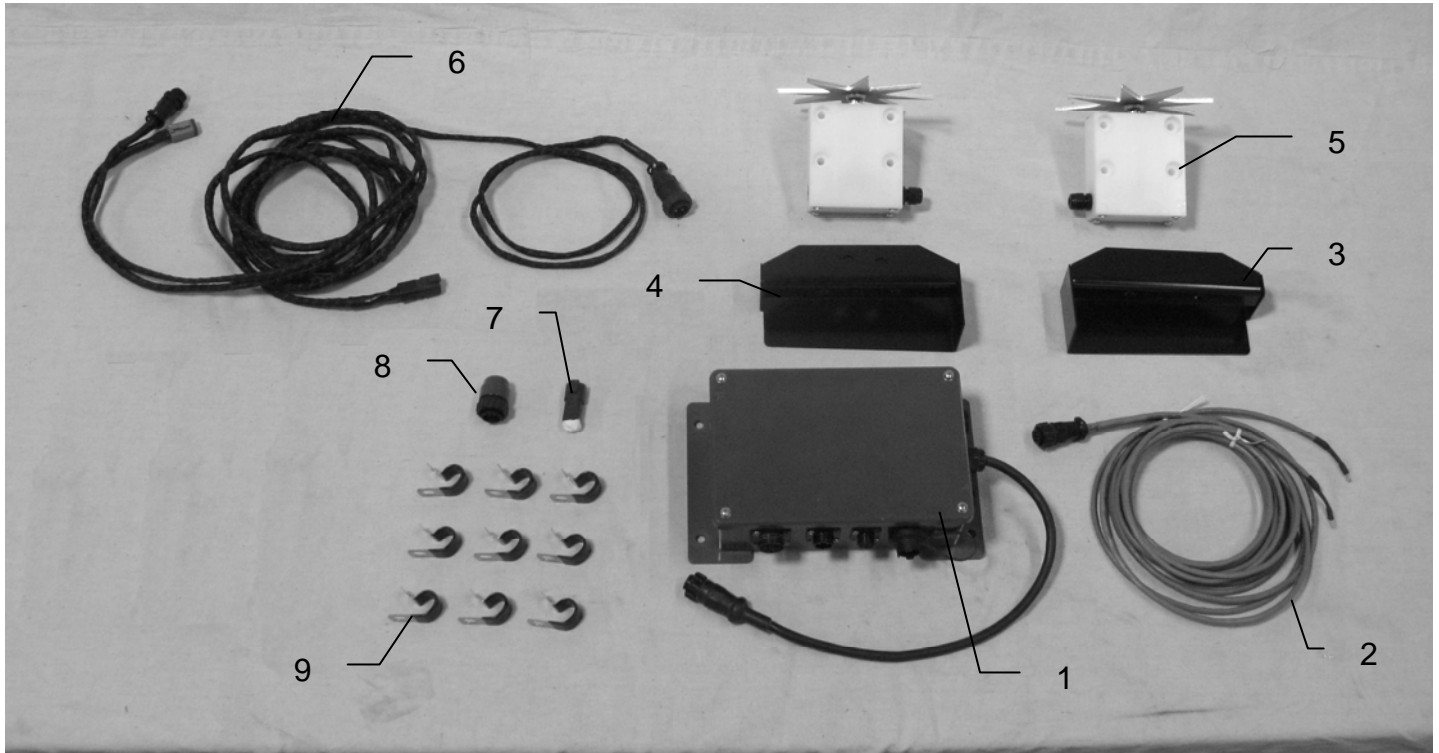

<u>Ref</u>	<u>Description</u>	<u>Part#</u>	<u>Qty</u>
1	PIP	006-5671LS2	1
2	Moisture harness	006-4640E2	1
3	Right twine diverter	001-4644	1
4	Left twine diverter	001-4645	1
5	Star wheel	030-4641	2
6	Can/Power harness	006-5650I	1
7	Resistor plug	006-4640J	1
8	Terminating resistor	006-5650Z	1
9	Jiffy clips	008-9018	9

NOTES:

WARRANTY AND LIABILITY AGREEMENT

Harvest Tec, Inc. will repair or replace components that are found to be defective within 12 months from the date of manufacture. Under no circumstances does this warranty cover any components which in the opinion of Harvest Tec, Inc. have been subjected to negligent use, misuse, alteration, accident, or if repairs have been made with parts other than those manufactured and obtainable from Harvest Tec, Inc.

Our obligation under this warranty is limited to repairing or replacing free of charge to the original purchaser any part that in our judgment shows evidence of defective or improper workmanship, provided the part is returned to Harvest Tec, Inc. within 30 days of the failure. Parts must be returned through the selling dealer and distributor, transportation charges prepaid.

This warranty shall not be interpreted to render Harvest Tec, Inc. liable for injury or damages of any kind, direct, consequential, or contingent, to persons or property. Furthermore, this warranty does not extend to loss of crop, losses caused by delays or any expense prospective profits or for any other reason. Harvest Tec, Inc. shall not be liable for any recovery greater in amount than the cost or repair of defects in workmanship.

There are no warranties, either expressed or implied, of merchantability or fitness for particular purpose intended or fitness for any other reason.

This warranty cannot guarantee that existing conditions beyond the control of Harvest Tec, Inc. will not affect our ability to obtain materials or manufacture necessary replacement parts.

Harvest Tec, Inc. reserves the right to make design changes, improve design, or change specifications, at any time without any contingent obligation to purchasers of machines and parts previously sold.

Revised 01/03/06

HARVEST TEC, INC.
P.O. BOX 63
2821 HARVEY STREET
HUDSON, WI 54016
PHONE: 715-386-9100
1-800-635-7468
FAX: 715-381-1792
Email: info@harvesttec.com