

OWNER'S MANUAL

Model 496 *100 & 110 Gallon Preservative Applicator*



*Equipment and Products
for Quality Hay.*

010-0496

REVISED 12-07

HARVEST TEC 496 TABLE OF CONTENTS

	<u>PAGE</u>
INSTALLATION KIT REFERENCE CHART	5
TOOLS NEEDED	5
INSTALLATION OF APPLICATOR	6-32
1. INSTALLATION OF PUMP PLATE	6-9
HESSTON, NEW IDEA, CHALLENGER, MASSEY FERGUSON, & CASE 8570, 8575, 8580, 8585, & 8590 BALERS	6
CASE & NEW HOLLAND	7
CLAAS, VERMEER, & KRONE BALERS	8
VICON & TAARUP BALERS	9
2. INSTALLATION OF TANK AND STAR WHEELS	10-18
NEW HOLLAND 590 THROUGH BB 960A & CASE IH LBX331 THROUGH LBX432 BALERS	11
CASE IH 8570, 8575, & 8585, CHALLENGER LB33, LB34, & HESSTON 7430, 4750, 4755, 4760, 4790, & MASSEY FERGUSON 2050, & NEW IDEA 7233, 7333, & 7234 BALERS	12
CASE IH 8580, 8590 & HESSTON 4900, 4910 & CHALLENGER LB 44 & NEW IDEA 7244 BALERS	13
AGCO HESSTON 7433, 7434, 7444 & CHALLENGER LB33B, LB34B & MASSEY FERGUSON 2150, 2170, & 2190 BALERS	14
VERMEER BALERS	15
CLAAS 2100 & 2200 BALERS	16
KRONE BALERS	17
VICON LB 8200 & LB 12200 BALERS & TAARUP 6570 – 6690 OC	18
3. INSTALLATION OF DRAIN/FILL LINE	19
4. INSTALLATION OF SPRAY SHIELD	20-29
4438B Vermeer SQ 2731	20
4439B Vermeer SQ3347	21
4490B Case IH 8570 and 8575, Hesston 4750 and 4755, and New Idea 7233	21
4491B Hesston 4900, 4910, Challenger LB44, Case IH 8580 and 8590, and New Idea 7244	22
4492B Hesston 4790, Case IH 8585, Challenger LB34, and New Idea 7234	22
4494B Challenger LB33, Hesston 4760, and New Idea 7333	23
4495B New Holland 590 through BB960A, and Case IH LBX331 through LBX432 and Krone VFS 88 and 128 with cutter	23
4497B Case IH LBX331 through LBX432, New Holland BB940 through BB960A roto-cut	24
4498B Krone VFS88 and VFS128	24
4499B Claas	25
4500B Hesston 4760 with cutter	25
4501B Hesston 4790 with cutter	26
4509B Claas 2100 with cutter	26
4510B Vicon LB 8200 & Taarup 6570 – 6570 OC	27
4511B Vicon LB 12200 & Taarup 6670 – 6690 OC	27
4514B Krone 890 - 12130 XC	28
4515B Krone 890 – 12130	28
4518 Agco large square	29
4519 Agco large square with cutter	29
5. PLUMBING	30
6. WIRING THE STAR WHEEL HARNESS	31
7. INSTALLATION OF THE BALE RATE SENSORS	31
8. INSTALLATION OF CONTROLS	31

9. INSTALLATION OF DISPLAY CABLE HARNESS	31
10. MAIN WIRING HARNESS AND POWER CORD INSTALLATION	31
WIRING INSTALLATION	32
11. DESCRIPTION OF BUTTONS	33
12. FIRST TIME AND ANNUAL START UP INSTRUCTIONS	34
CHECKING AND PRIMING THE PUMPS	34
13. SETTING UP THE SYSTEM FOR INITIAL USE	35
APPLICATION RATE	35
BALING RATE	36
OPERATING INSTRUCTIONS	37-40
AUTOMATIC MODE	37
MANUAL MODE	38
JOB RECORDS	39
DIAGNOSTICS	40
COMMON QUESTIONS ABOUT THE 465	41
MAINTENANCE	42
MAINTENANCE SCHEDULE	42
WINTER STORAGE	42
TROUBLE SHOOTING	43-44
BACKUP FUSE	44
WIRING DIAGRAMS	45-46
PARTS BREAKDOWN	47-68
TANK, SADDLE, AND LEGS	47
PUMP PLATE	48
STAR WHEELS	49
CONTROL BOX AND WIRING HARNESES AND HOSES	50
4438B	51
4439B	52
4490B	53
4491B	54
4492B	55
4494B	56
4495B	57
4497B	58
4499B	59
4500B	60
4501B	61
4509B	62
4510B	63
4511B	64
4514B	65
4515B	66
4518B	67
4519B	68
VICON TEMPLATE	69
TEMPLATE	70
NOTES	71
WARRANTY STATEMENT	BACK PAGE

INTRODUCTION

Congratulations on purchasing a Harvest Tec Model 496 applicator. This applicator is designed to apply Harvest Tec buffered propionic acid. The use of other products can cause application problems and damage to system components. The model 496 base kit includes the following parts: Tank, Frame, Pumps, Hose, Baler Mounted Processor, Touchscreen Display, Moisture Sensors, and Miscellaneous Hardware. The applicator can be installed on most large square balers with the proper installation kit. Before installing the unit on the baler, make sure you have the proper installation kit. (See the chart on following page.) If you are unsure about your installation kit contact your dealership for specifications. For your convenience we have included a parts break down for the model 496 applicator. If something goes wrong, bring this manual into the dealership so they can order the correct parts for you. Ordering the correct part number is very important. It will save you time, money, and your crop.

INSTALLATION KIT REFERENCE CHART

BALER MAKE	MODEL	INSTALL KIT
AGCO	4750-4755	030-4490B
HESSTON	4760	030-4494B
	4790	030-4492B
	4900-4910	030-4491B
	4760 ROTO-CUTTER	030-4500B
	4790 ROTO-CUTTER	030-4501B
	7430	030-4494B
	7430 ROTO-CUTTER	030-4500B
	7433-7444	030-4518B
	7433-7434 ROTO-CUTTER	030-4519B
CASE IH	8570-8575	030-4490B
	8585	030-4492B
	8580-8590	030-4491B
	LBX331-332 STD OR PACKER	030-4495B
	LBX431-432 STD OR PACKER	030-4495B
	LBX331-332 ROTO-CUTTER	030-4497B
	LBX431-432 ROTO-CUTTER	030-4497B
CHALLENGER	LB33	030-4494B
	LB34	030-4492B
	LB44	030-4491B
	LB33B – LB44B	030-4518B
	LB33B – LB34B ROTO-CUTTER	030-4519B
KRONE	VFS 88	030-4498B
	VFS 88 CUTTER	030-4495B
	VFS 128	030-4498B
	VFS 128 CUTTER	030-4495B
	890-12130 XC	030-4514B
	890-12130	030-4515B
CLAAS	2200	030-4499B
	2100	030-4509B
MASSEY FERGUSON	2050	030-4494B
	2050 ROTO-CUTTER	030-4500B
	2150 – 2190	030-4518B
	2150 – 2170 ROTO-CUTTER	030-4519B
NEW IDEA	7233	030-4490B
	7234	030-4492B
	7244	030-4491B
	7333	030-4494B
NEW HOLLAND	590-BB940A STD OR PACKER	030-4495B
	595-BB960A STD OR PACKER	030-4495B
	BB940-BB940A ROTO-CUTTER	030-4497B
	BB960-BB960A ROTO-CUTTER	030-4497B
TAARUP	6570 – 6570 OC	030-4510B
	6670 – 6690 OC	030-4511B
VERMEER	SQ2731	030-4438B
	SQ3347	030-4439B
VICON	LB 8200	030-4510B
	LB 12200	030-4511B

TOOLS NEEDED FOR INSTALLATION:

- Standard wrench set
- Electric drill and bits
- Side cutter
- Crescent wrench
- Standard screwdriver
- Standard nut driver set
- Standard socket set
- Hammer
- Metal cutting tools
- Hose cutter
- Center punch

INSTALLATION OF APPLICATOR

1. INSTALLATION OF PUMP PLATE

Hesston, New Idea, Challenger, Massey Ferguson, and Case 8570, 8575, 8580, 8585, 8590 balers:

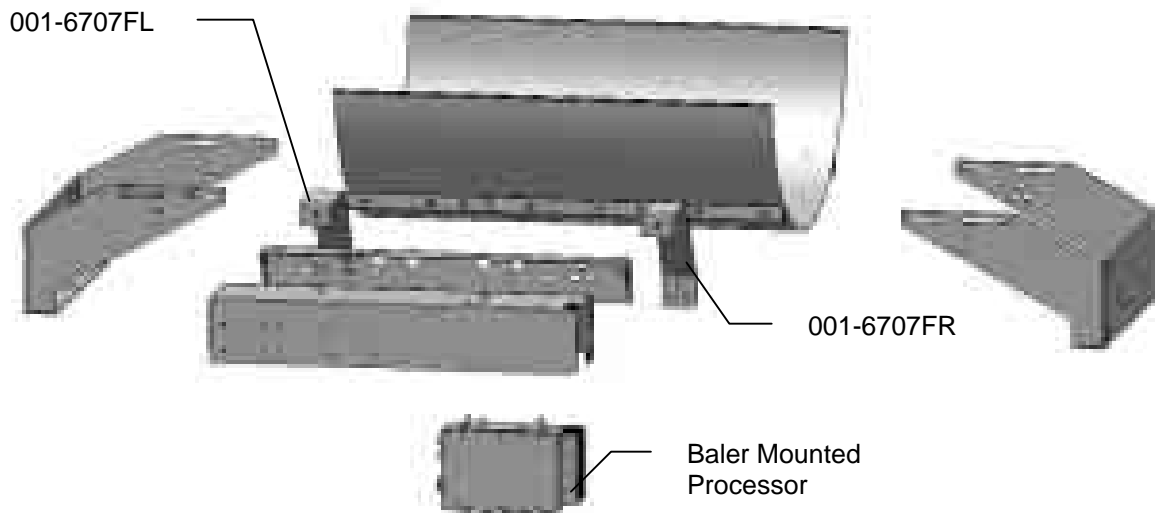

FOR 3 X 3 BALERS ONLY

Install both saddle legs (001-6707C) onto the saddle (001-6707A) with 3/8 x 1" Bolts, locks and flat washers. Note: the slots in the legs will attach to the second and fourth weld nuts in from each end, of the saddle, on both sides.

1. Once legs and saddle are loosely attached measure the distance from the top outside corners of the bale chamber where the saddle will be attached. Move legs in or out so the outside edges will match this dimension. Also try to center the saddle within these dimensions. Do not fully tighten bolts until mounted on the baler
2. Mount the pump plate support legs (001-6707FL & 001-6707FR) to the saddle legs using six 3/8" x 1 1/4" bolts, locks, flats, and nuts. Note: this will be the side that is opposite of the "V" notch that is in the sump cut out of the saddle
3. Attach the pump plate mounting bracket (001-4646C) to the pump plate support legs with two 3/8" x 1 1/4" bolts, locks, flats, and nuts.
4. Attach the pump plate holder (001-4646D) to the pump plate mounting bracket (001-4646C) using four 3/8" x 3/4" flange head bolts

FOR 3 X 4 and 4 x 4 BALERS ONLY

Install both saddle legs (001-6707C) onto the saddle (001-6707A) with 3/8 x 1" Bolts, locks and flat washers. Note: the slots in the legs will attach to the first and third weld nuts in from each end, of the saddle, on both sides.

1. Once legs and saddle are loosely attached measure the distance from the top outside corners of the bale chamber where the saddle will be attached. Move legs in or out so the outside edges will match this dimension. Also try to center the saddle within these dimensions. Do not fully tighten down bolts until mounted on the baler.
2. Mount the pump plate support legs (001-6707FL & 001-6707FR) to the saddle legs using six 3/8" x 1 1/4" bolts, locks, flats, and nuts. Note: this will be the side that is opposite of the "V" notch that is in the sump cut out of the saddle
3. Attach the pump plate mounting bracket (001-4646C) to the pump plate support legs with two 3/8" x 1 1/4" bolts, locks, flats, and nuts.
4. Attach the pump plate holder (001-4646D) to the pump plate mounting bracket (001-4646C) using four 3/8" x 3/4" flange head bolts

The Baler Mounted Processor and pump heads must be pointing down. Failure to mount the pump plate assembly in this specified direction will void all warranty of the Baler Mounted Processor and pumps.

Case & New Holland

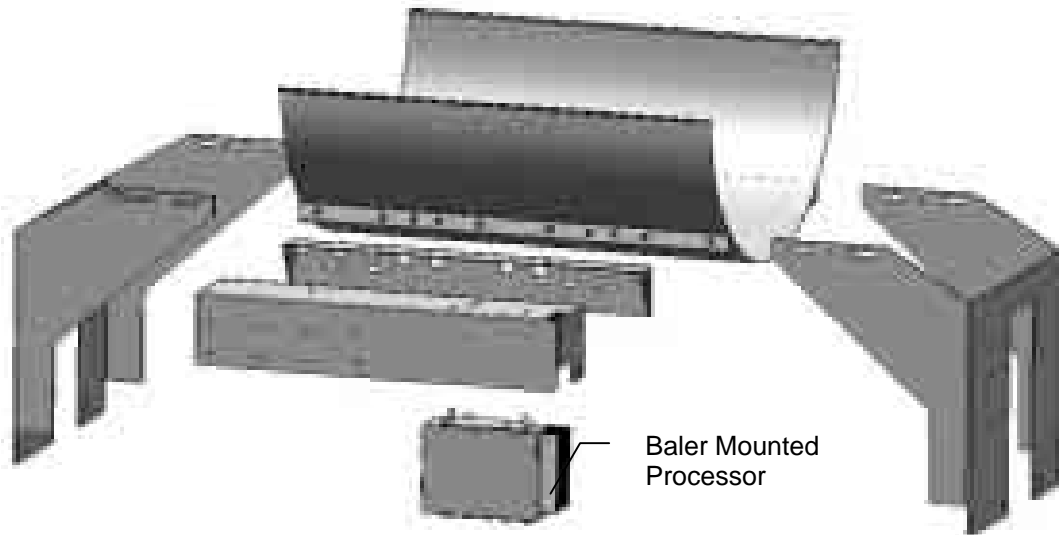

FOR 3 X 3 BALERS ONLY

Install both saddle legs (001-6707BL & 001-6707BR) onto the saddle (001-6707A) with 3/8 x 1" Bolts, locks and flat washers. The mounting slots in the legs will attach to the second and fourth weld nuts in from each end, of the saddle, on both sides. Note: There is a "V" shape cut out in the sump area of the saddle. This side of the saddle should be attached to the side of the legs that have a narrower profile.

1. Once legs and saddle are loosely attached measure the distance from the top outside corners of the bale chamber where the saddle will be attached. Move legs in or out so the inside edges will match this dimension. Also try to center the saddle within these dimensions. Do not fully tighten down bolts until unit is mounted on the baler
2. Connect the pump plate mounting bracket (001-4646C) to the side of the saddle that has the wider profile to the legs. Note: you will have to remove the two outside bolts and replace them with two 3/8" x 1 1/4" bolts.
3. Attach the pump plate holder (001-4646D) to the pump plate mounting bracket (001-4646C) using four 3/8" x 3/4" flange head bolts

FOR 3 X 4 BALERS ONLY

Install both saddle legs (001-6707BL & 001-6707BR) onto the saddle (001-6707A) with 3/8 x 1" Bolts, locks and flat washers. The mounting slots in the legs will attach to the first and third weld nuts in from each end, of the saddle, on both sides. Note: There is a "V" shape cut out in the sump area of the saddle. This side of the saddle should be attached to the side of the legs that have a narrower profile.

1. Once legs and saddle are loosely attached measure the distance from the top outside corners of the bale chamber where the saddle will be attached. Move legs in or out so the inside edges will match this dimension. Also try to center the saddle within these dimensions. Do not fully tighten down bolts until unit is mounted on the baler
2. Connect the pump plate mounting bracket (001-4646C) to the side of the saddle that has the wider profile to the legs. Note: you will have to remove the two inside bolts and replace them with two 3/8" x 1 1/4" bolts.
3. Attach the pump plate holder (001-4646D) to the pump plate mounting bracket (001-4646C) using four 3/8" x 3/4" flange head bolts

The Baler Mounted Processor and pump heads must be pointing down. Failure to mount the pump plate assembly in this specified direction will void all warranty of the Baler Mounted Processor and pumps

Claas, Vermeer, and Krone balers

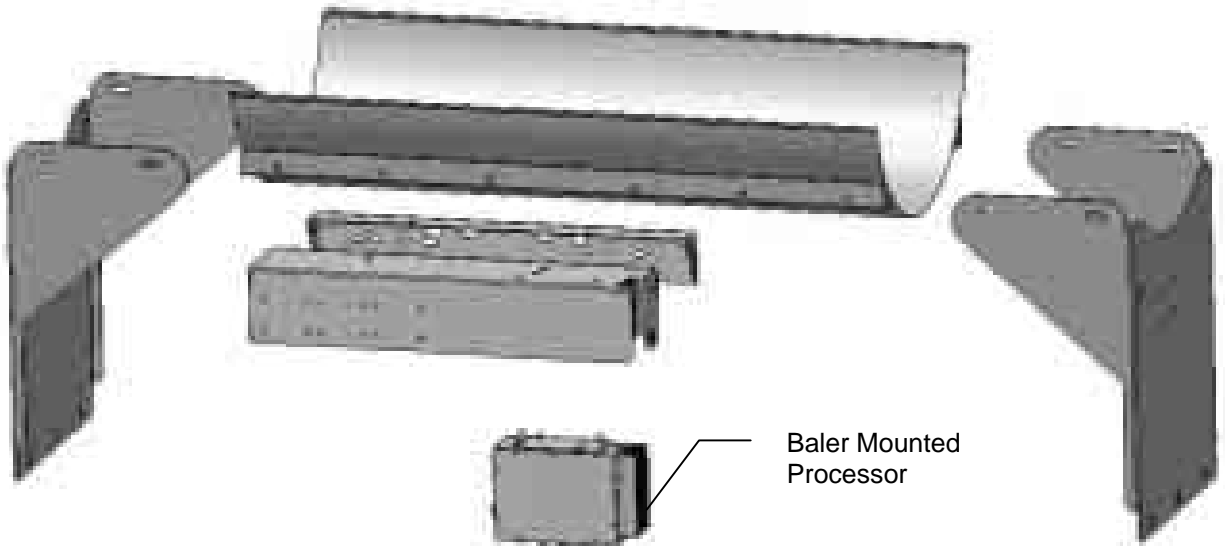

FOR 3 X 3 BALERS ONLY

Install both saddle legs (001-6706V) onto the saddle (001-6706A) with 3/8 x 1" Bolts, locks and flat washers. The mounting slots in the legs will attach to the second and third weld nuts in from each end, of the saddle, on both sides

1. Once legs and saddle are loosely attached measure the distance from the top outside corners of the bale chamber where the saddle will be attached. Move legs in or out so the inside edges will match this dimension. Also try to center the saddle within these dimensions. Do not fully tighten down bolts until unit is mounted on the baler
2. Connect the pump plate mounting bracket (001-4646C) to the saddle. You will have to remove the two outside bolts and replace them with two 3/8" x 1 1/4" bolts. Note: this will be the side that is opposite of the "V" notch that is in the sump cut out of the saddle. Expect for Krone (see pg 16)
3. Attach the pump plate holder (001-4646D) to the pump plate mounting bracket (001-4646C) using four 3/8" x 3/4" flange head bolts

FOR 3 X 4 and 4 x 4 BALERS ONLY

Install both saddle legs (001-6707V) onto the saddle (001-6707A) with 3/8 x 1" Bolts, locks and flat washers. The mounting slots in the legs will attach to the first and second weld nuts in from each end, of the saddle, on both sides.

1. Once legs and saddle are loosely attached measure the distance from the top outside corners of the bale chamber where the saddle will be attached. Move legs in or out so the inside edges will match this dimension. Also try to center the saddle within these dimensions. Do not fully tighten down bolts until unit is mounted on the baler
2. Connect the pump plate mounting bracket (001-4646C) to the saddle. You will have to remove the two inside bolts and replace them with two 3/8" x 1 1/4" bolts. Note: this will be the side that is opposite of the "V" notch that is in the sump cut out of the saddle. Expect for Krone (see pg 16)
3. Attach the pump plate holder (001-4646D) to the pump plate mounting bracket (001-4646C) using four 3/8" x 3/4" flange head bolts.

The Baler Mounted Processor and pump heads must be pointing down. Failure to mount the pump plate assembly in this specified direction will void all warranty of the Baler Mounted Processor and pumps

Vicon & Taarup balers

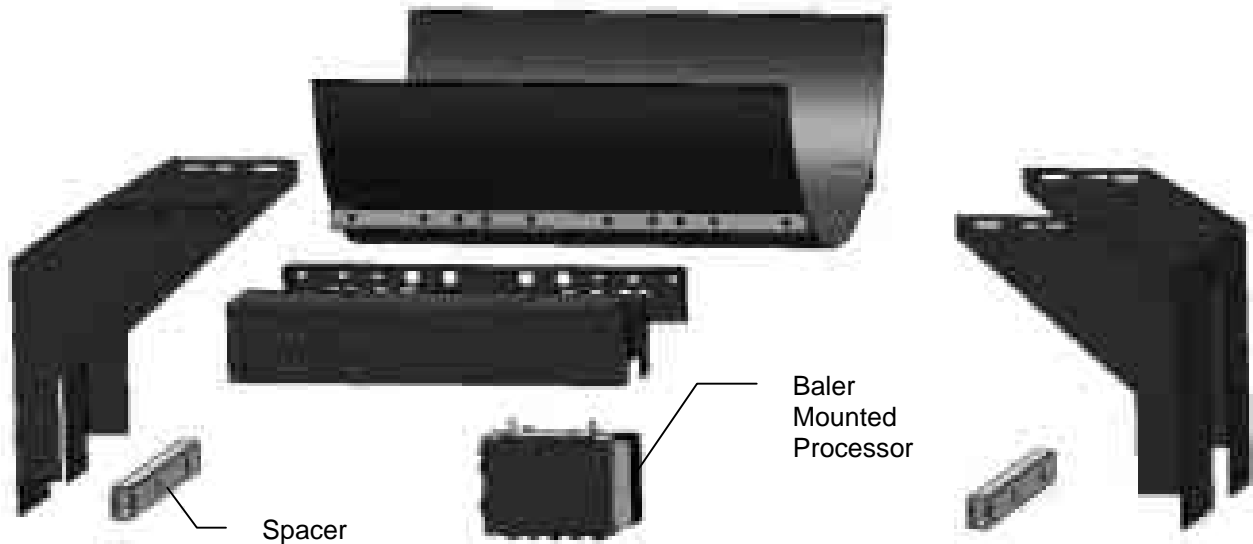

FOR 3 X 3 BALERS ONLY

Install both saddle legs (001-6707BL & 001-6707BR) onto the saddle (001-6707A) with 3/8 x 1" Bolts, locks and flat washers. The mounting slots in the legs will attach to the second and fourth weld nuts in from each end, of the saddle, on both sides. Note: There is a "V" shape cut out in the sump area of the saddle. This side of the saddle should be attached to the side of the legs that have a narrower profile.

1. Once legs and saddle are loosely attached measure the distance from the top outside corners of the bale chamber where the saddle will be attached. Move legs in or out so the inside edges will match this dimension. Also try to center the saddle within these dimensions. Do not fully tighten down bolts until unit is mounted on the baler
2. Connect the pump plate mounting bracket (001-4646C) to the side of the saddle that has the wider profile to the legs. Note: you will have to remove the two outside bolts and replace them with two 3/8" x 1 1/4" bolts.
3. Attach the pump plate holder (001-4646D) to the pump plate mounting bracket (001-4646C) using four 3/8" x 3/4" flange head bolts

FOR 3 X 4 BALERS ONLY

Install both saddle legs (001-6707BL & 001-6707BR) onto the saddle (001-6707A) with 3/8 x 1" Bolts, locks and flat washers. The mounting slots in the legs will attach to the first and third weld nuts in from each end, of the saddle, on both sides. Note: There is a "V" shape cut out in the sump area of the saddle. This side of the saddle should be attached to the side of the legs that have a narrower profile.

1. Once legs and saddle are loosely attached measure the distance from the top outside corners of the bale chamber where the saddle will be attached. Move legs in or out so the inside edges will match this dimension. Also try to center the saddle within these dimensions. Do not fully tighten down bolts until unit is mounted on the baler
2. Connect the pump plate mounting bracket (001-4646C) to the side of the saddle that has the wider profile to the legs. Note: you will have to remove the two inside bolts and replace them with two 3/8" x 1 1/4" bolts.
3. Attach the pump plate holder (001-4646D) to the pump plate mounting bracket (001-4646C) using four 3/8" x 3/4" flange head bolts

The Baler Mounted Processor and pump heads must be pointing down. Failure to mount the pump plate assembly in this specified direction will void all warranty of the Baler Mounted Processor and pumps

2. INSTALLATION OF TANK AND STAR WHEELS

Use the template located in the back of this manual as a guide for cutting a notch and locating the mounting holes for the star wheels. Carefully mark the location of the star wheel holes using the template and a center punch so the star wheels will run true to the direction of the bales, otherwise, the star wheels may work themselves out of the block. The star wheels must be mounted so that they are no closer than 3/8" from any metal parts of the baler and come in contact only with the bale. Four 5/16" allen headed bolts will be used to mount the star wheel block and twine guard to the baler. The bolts must be inserted from the inside of the baler chamber. Use nuts and lock washers to hold the bolts in place before putting on the star wheel block, the block is counter-bored on one side so the block will fit over the nuts. The star wheel block has a plug on one side and a wire grommet on the other side. If there are interference problems with the star wheel wires on one side of the block, exchange the wire grommet with the plug so the wire can exit the block on the other side. Mount the twine guards using the two inner holes on the star wheel block. **The twine guard containing the bale rate sensors should be placed on the baler's right side, when looking from the back of the baler.

The following pages will contain detailed instructions for your baler. Please refer to the table of contents for you exact listing.

New Holland 590 through BB960A and Case IH LBX331 through LBX 432 balers

Mount the tank legs and saddle on the baler as shown below. The tank legs bolt to the baler with ½" carriage bolts (qty 6). Depending on the baler model, 9/16" holes (3 per side) may need to be drilled in the baler to bolt down the tank legs. The bolts should be inserted from inside the baler.

The saddle is intentionally tipped forward by 5° so that the tank cap will be parallel to the ground. There is a small cut out "V" where the tank sump fits in the saddle and this cut out should face the back of the baler for the tank to be level when installed on the baler.

Use the template located in the back of the manual as a guide for cutting the notch and mounting holes for the star wheels. The star wheels are to be mounted on top of the baler, just behind the knotters and under the walkway on both sides. Remove the bale from the chute, tip the walkway up and locate the wheels on the top outside corner angles of the bale chute, one on each side. Some balers may already have the notch cut and square holes. If so, the holes will need to be drilled round with a 5/16" drill bit. A 1/2" x 1/2" cut may also need to be made at the base of the twine arm mounting bracket for the star wheel to sit correctly on the bale chamber. Mark the location of the notch (5/8" wide and 9" long) and the location of the four 5/16" holes for the star wheel base. After cutting the notch and drilling the hole, insert the 5/16" by 3 ¼" black allen head bolts up through the chute and use nuts to hold the bolts in place. Place the star wheel block over the nuts and install the twine guards using the two inner holes of the star wheel block. **The twine guard containing the bale rate sensors will be placed on the right side.** See Step 7 for directions on how to hook-up the star wheel wires.

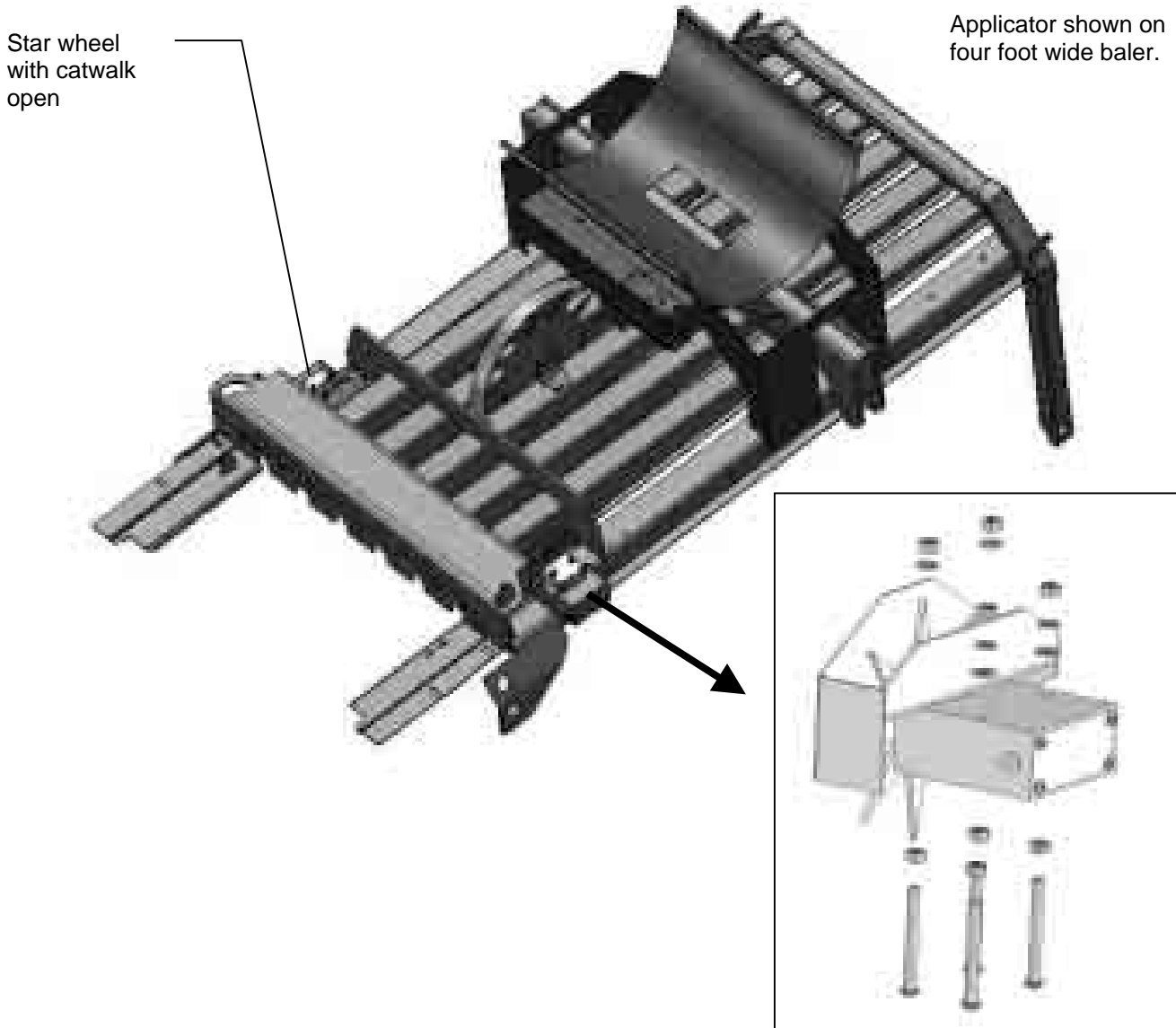

Case IH 8570, 8575, and 8585, Challenger LB33, LB34, and Hesston 7430, 4750, 4755, 4760, and 4790, and Massey Ferguson 2050, and New Idea 7233, 7333, 7234 balers

Mount the tank legs and saddle on the baler as shown below, centered between the compression arm and the crossbeam. The tank legs bolt to the baler with ½” carriage bolts (qty 6). Depending on the baler model, 9/16” holes (3 per side) may need to be drilled in the baler to bolt down the tank legs. The bolts should be inserted from inside the baler.

The saddle is intentionally tipped forward by 5° so that the tank cap will be parallel to the ground. There is a small cut out “V” where the tank sump fits in the saddle and this cut out should face the back of the baler for the tank to be level when installed on the baler.

The star wheels are mounted under the walkway on top of the baler behind the knotters. Remove the bale from the chute and tip the walkway up. Locate the star wheel template on the outside corner angles of the bale chute on the left and right side of the baler. The center of the wheel shaft will be approximately 5½ inches in front of the walkway support or about halfway between the walkway support and the cross frame almost directly in front of it. The notch will start just in front of the walkway support.

Two parts of the baler frame will have to be trimmed off on both sides to mount each star wheel.

The first is the outside corner angles of the chute. Use the template to mark the location of the star wheel notch as well as the location of the four holes for the star wheel base. The notch will be 5/8” by 9” long and will help keep the wheel away from the twine. Spray the ground areas with touch up paint to prevent rusting. The second portion of the baler to trim off is the end of the gusset that may interfere with the star wheel’s plastic base support. Center the star wheel in the slots that was just notched and check for interference with the gusset.

Drill 5/16” holes for the star wheel block. Insert the 5/16” by 3 ¼” bolts up through the chute and use nuts to hold the bolts in place. Place the star wheel block over the nuts and install the twine guards using the two inner holes of the star wheel block. **The twine guard containing the bale rate sensors will be placed on the right side of the baler.** See Step 7 for directions on how to hook-up the star wheel wires.

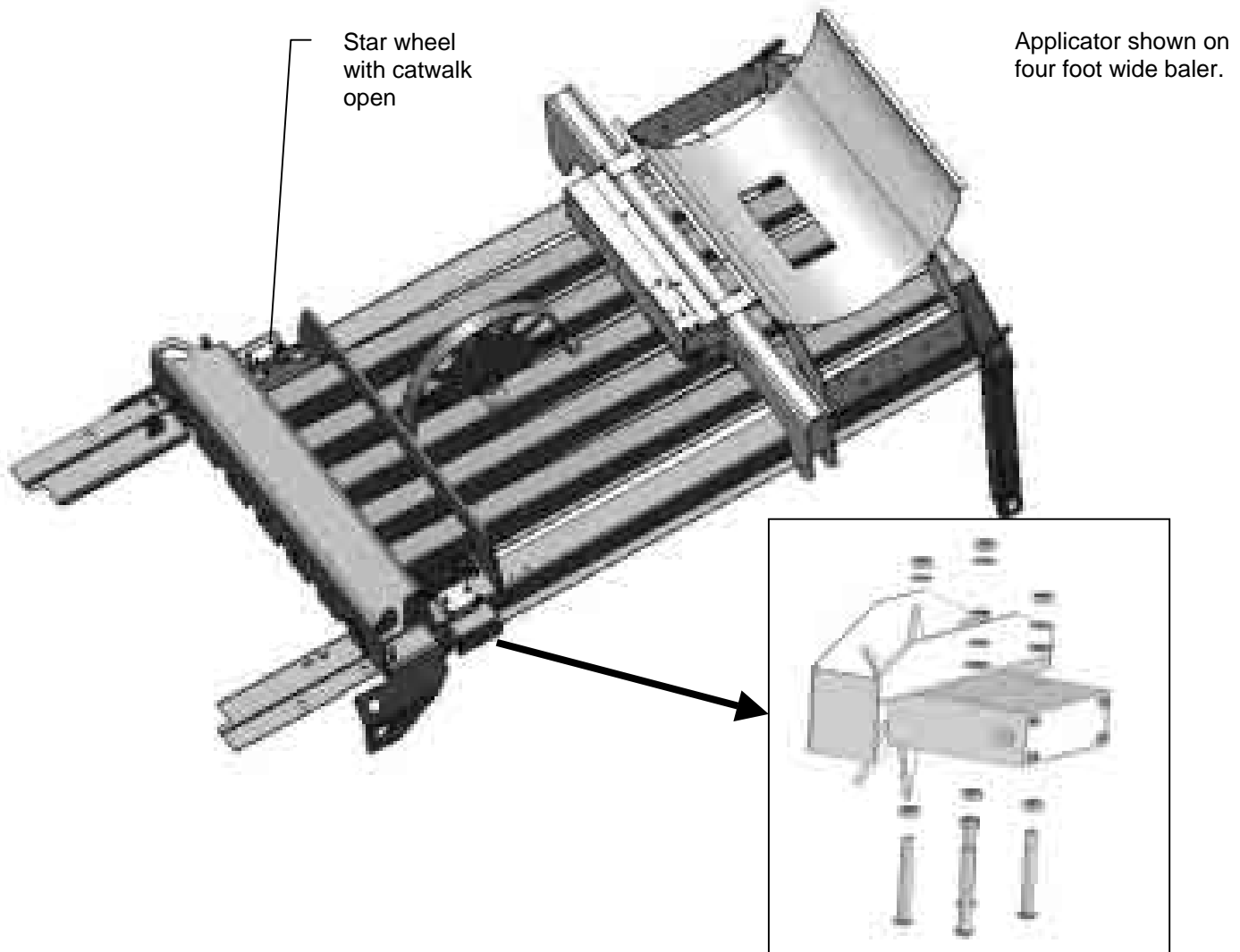

Case IH 8580 and 8590, Hesston 4900 and 4910, Challenger LB44, and New Idea 7244 balers

Mount the tank legs and saddle on the baler as shown below, centered between the compression arm and the crossbeam. The tank legs bolt to the baler with ½" carriage bolts (qty 6). Depending on the baler model, 9/16" holes (3 per side) may need to be drilled in the baler to bolt down the tank legs. The bolts should be inserted from inside the baler. Bolt the ladder bracket extensions (001-6707H) on the side of the tank legs and attach the balers existing ladder.

The saddle is intentionally tipped forward by 5° so that the tank cap will be parallel to the ground. There is a small cut out "V" where the tank sump fits in the saddle and this cut out should face the back of the baler for the tank to be level when installed on the baler.

The star wheels are mounted on top of the baler, just behind the knotters under the walkway on both sides. Use the template at the back of the manual to mark the location and dimension of the notch and holes. Remove the bale from the chute. Tip the walkway up and locate the wheels on the top outside corner angles of the bale chute, one on each side. The star wheel block is located just in front of the horizontal channels holding the twine boxes. Using the template, mark the location of the notch (5/8" wide and 9" long) and the location of the four 5/16" holes for the star wheelbase using a center punch. The bare metal edge of the angle should be sprayed with touch up paint to prevent corrosion.

Once the above modification to the baler is made on both sides of the chute, the wheels can be mounted. Insert the 5/16" by 3 ¼" bolts up through the chute and use nuts to hold the bolts in place. Place the star wheel block over the nuts and install the twine guards using the two inner holes of the star wheel block. **The twine guard containing the bale rate sensors will be placed on the right side of the baler.** See Step 7 for directions on how to hook-up the star wheel wires.

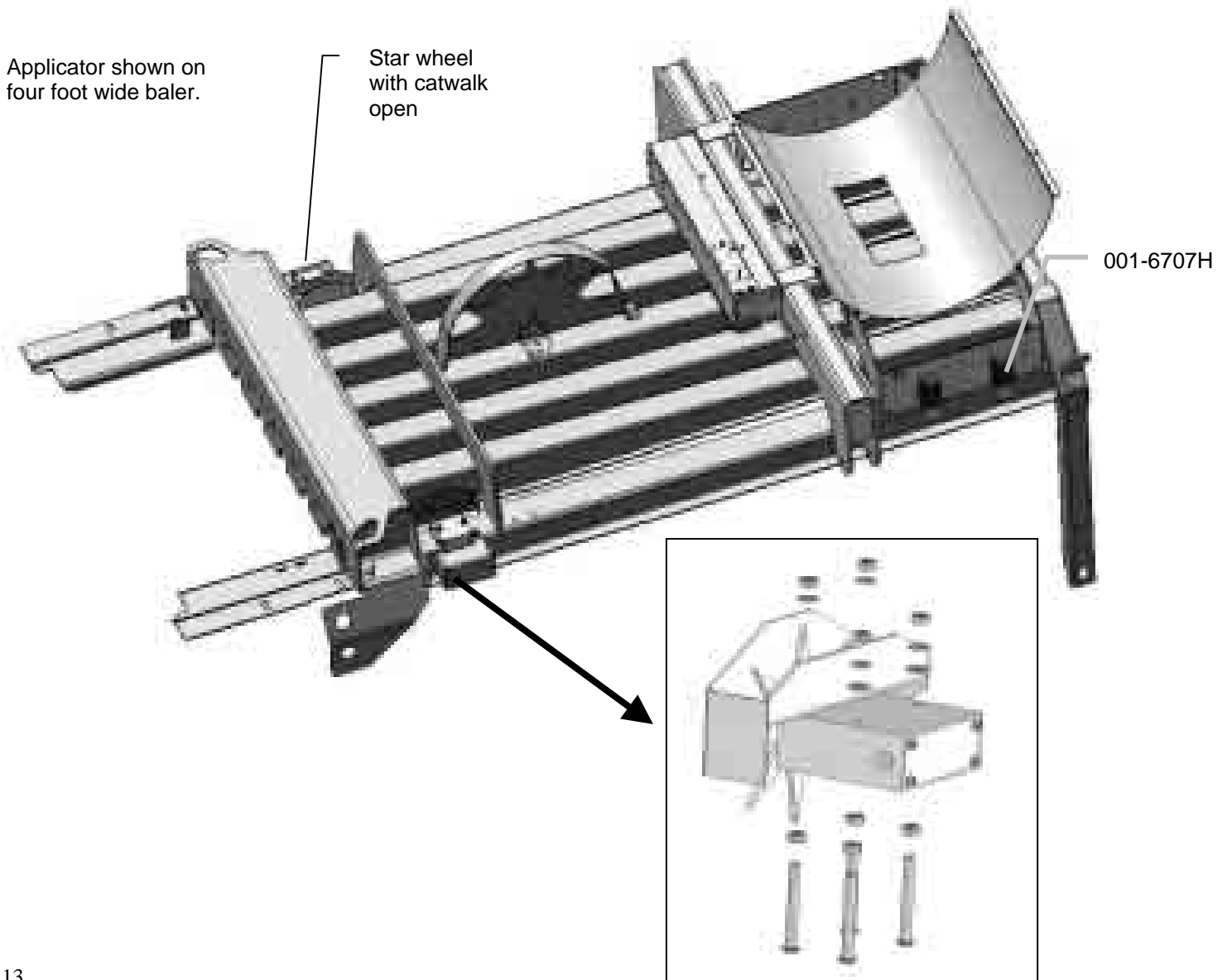

Agco Hesston 7433, 7434, 7444, and Challenger LB33B, LB34B, LB44B, and Massey Ferguson 2150, 2170, 2190

Mount the tank legs and saddle on the baler as shown below, just behind the compression arm. The tank legs bolt to the baler with ½" carriage bolts (qty 6). Depending on the baler model, 9/16" holes (3 per side) may need to be drilled in the baler to bolt down the tank legs. The bolts should be inserted from inside the baler.

The saddle is intentionally tipped forward by 5° so that the tank cap will be parallel to the ground. There is a small cut out "V" where the tank sump fits in the saddle and this cut out should face the back of the baler for the tank to be level when installed on the baler

The star wheels are to be mounted on top of the baler, just behind the knotters and under the walkway on both sides. The notch and holes for the star wheel are pre cut. Place the spacer plate (001-6707E) over the pre cut holes. Attach with 5/16 x 1/2 allen head bolts and internal star washers from inside the bale chamber. Center the star wheels over the top of the spacer plate, place the twine diverters on top of the star wheel and attach with 5/16 x 2 1/4 hex bolt and lock washers. For remainder two holes per star wheel attach with 5/16 x 2 1/4" hex bolt, lock washer, and one 5/16" thick flat washers per bolt. Verify that star wheels align with bale chamber before tightening down all hardware. **The twine guard containing the bale rate sensors will be placed on the right side of the baler.** See Step 7 for directions on how to hook-up the star wheel wires.

Applicator shown on four foot wide baler.

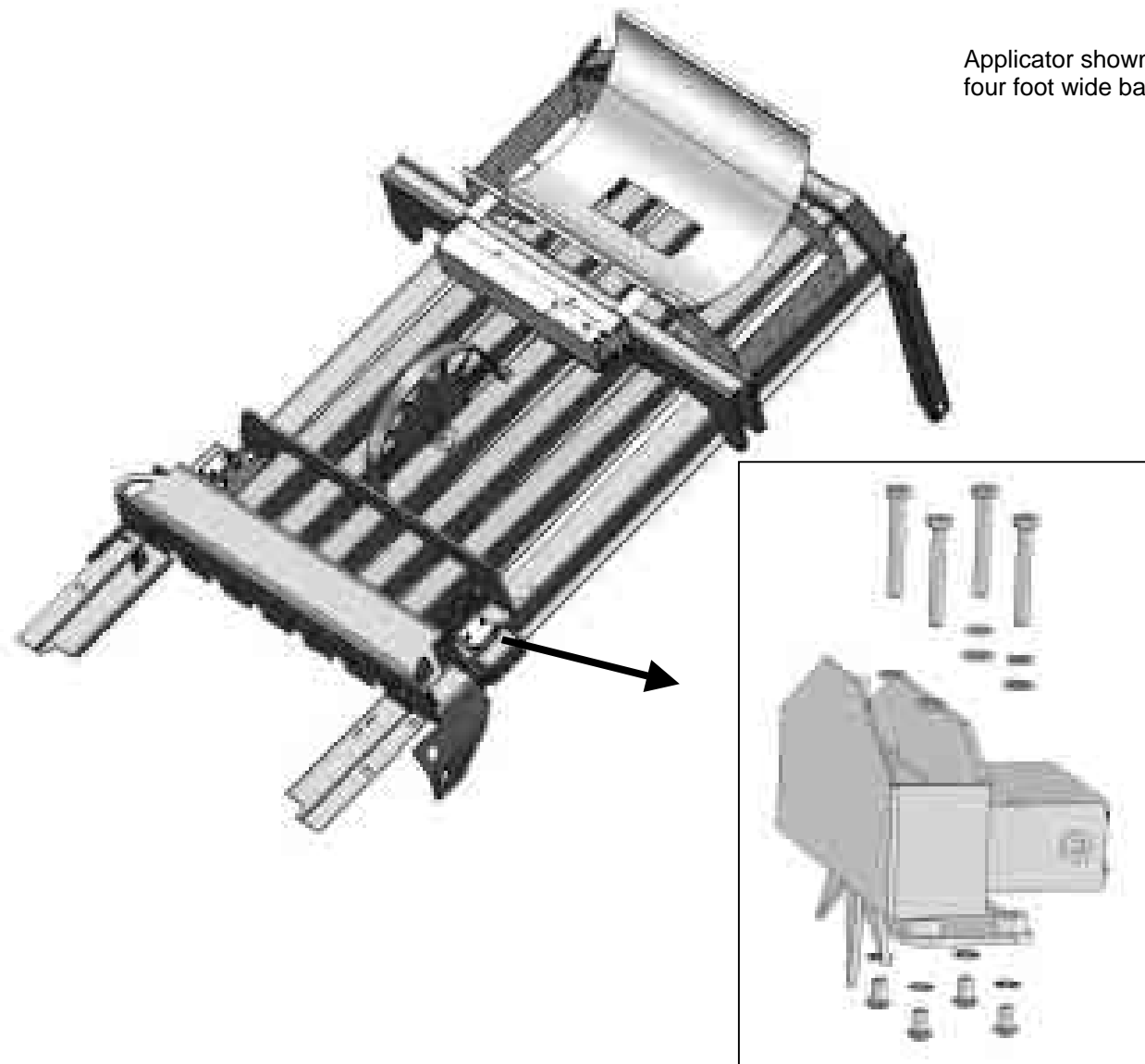

Vermeer SQ2731 and SQ3347 balers

Mount the tank legs and saddle on the baler as shown below. The tank legs bolt to the baler with ½" carriage bolts (qty 6). You will need to drill 9/16" holes (3 per side) in the baler to bolt down the tank legs. The bolts should be inserted from inside the baler.

The saddle is intentionally tipped forward by 5° so that the tank cap will be parallel to the ground. There is a small cut out "V" where the tank sump fits in the saddle and this cut out should face the back of the baler for the tank to be level when installed on the baler.

Locate the steel crossbeam that goes across the bale chamber in between the knotters and shield for the hydraulic cylinder. The yellow shield is located in the middle and runs in the same direction as the bale chamber. Using the provided star wheel template, locate the template as far forward as possible behind the crossbeam. Position the template so the edge of the star wheel base is aligned with the outside of the bale chamber. Mark the hole positions for drilling and also mark the notch for the star wheels. The notch will be 5/8" by 9" long and will help keep the wheel away from the twine. Repeat this process on the other side of the bale chamber for the second star wheel. Insert the 5/16" by 3 ¼" bolts up through the chute and use nuts to hold the bolts in place. Place the star wheel block over the nuts and install the twine guards using the two inner holes of the star wheel block. **The twine guard containing the bale rate sensors will be placed on the right side of the baler.** See Step 7 for directions on how to hook-up the star wheel wires.

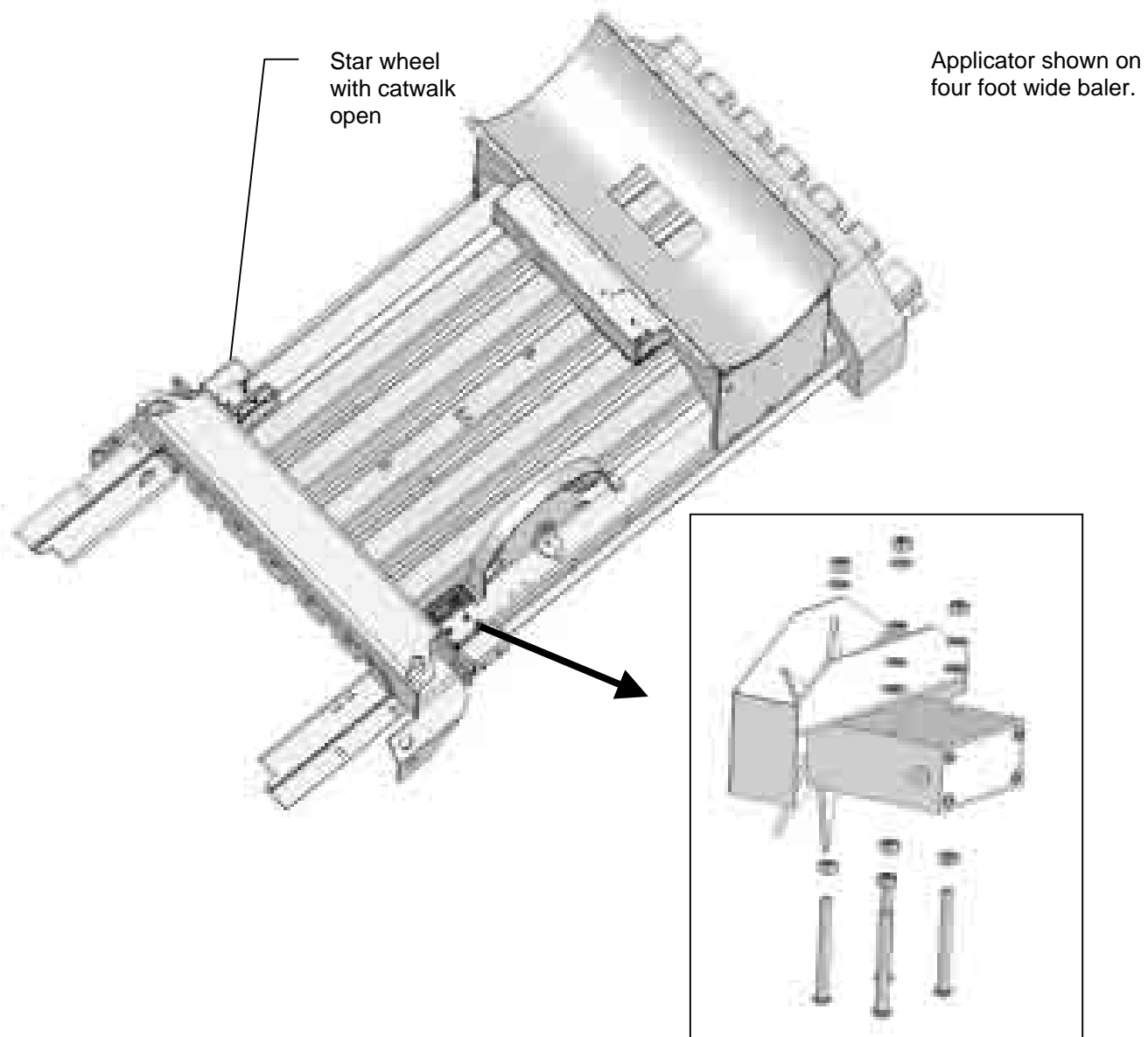

Claas 2100 and 2200 balers

Mount the tank legs and saddle on the baler as shown below. The tank legs bolt to the baler with ½" carriage bolts (qty 6). You will need to drill 9/16" holes (3 per side) in the baler to bolt down the tank legs. The bolts should be inserted from inside the baler. Make sure to mount the tank legs as far back as possible to allow room for using the ladder.

The saddle is intentionally tipped forward by 5° so that the tank cap will be parallel to the ground. There is a small cut out "V" where the tank sump fits in the saddle and this cut out should face the back of the baler for the tank to be level when installed on the baler.

Use the template located in the back of the manual as a guide for cutting the notch and mounting holes for the star wheels. The star wheels are to be mounted on top of the baler, just behind the knotters and as far forward as possible. Remove the bale from the chute. Locate the wheels on the top outside corner angles of the bale chute, one on each side. Mark the location of the notch (5/8" wide and 9" long) and the location of the four 5/16" holes for the star wheel base. After cutting the notch and drilling the hole, insert the 5/16" by 3 ¼" black allen head bolts up through the chute and use nuts to hold the bolts in place. Place the star wheel block over the nuts and install the twine guards using the two inner holes of the star wheel block. **The twine guard containing the bale rate sensors will be placed on the right side.** See Step 7 for directions on how to hook-up the star wheel wires.

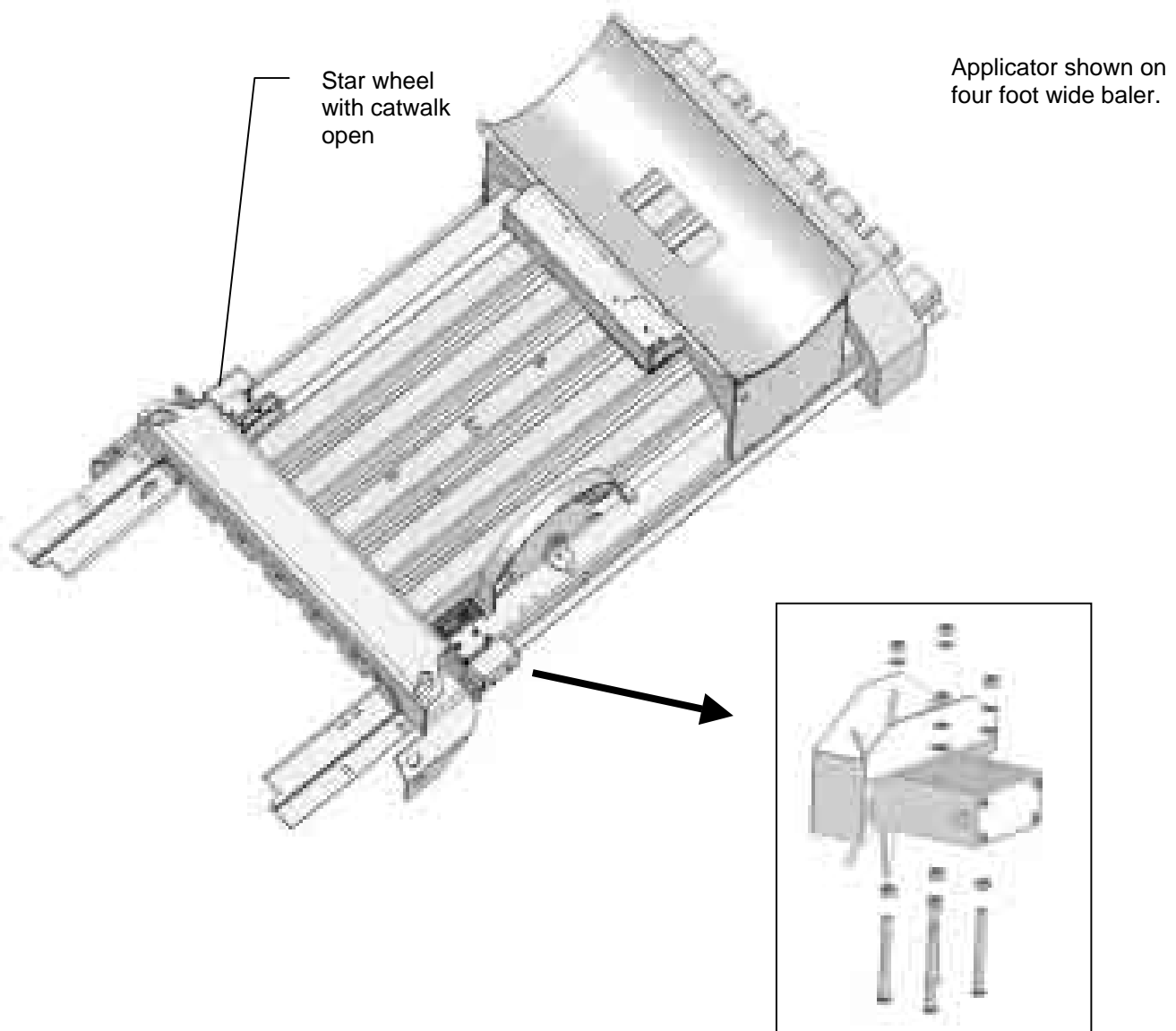

Krone large square

Mount the tank legs and saddle on the baler as shown below. The tank legs bolt to the baler with ½" carriage bolts (qty 6). You will need to drill 9/16" holes (3 per side) in the baler to bolt down the tank legs. The bolts should be inserted from inside the baler.

The saddle is intentionally tipped forward by 5° so that the tank cap will be parallel to the ground. There is a small cut out "V" where the tank sump fits in the saddle and this cut out should face the back of the baler for the tank to be level when installed on the baler.

Use the template located in the back of the manual as a guide for cutting the notch and mounting holes for the star wheels. The star wheels are to be mounted on top of the baler, just behind the knotters and as far forward as possible. Remove the bale from the chute. Locate the wheels on the top outside corner angles of the bale chute, one on each side. Mark the location of the notch (5/8" wide and 9" long) and the location of the four 5/16" holes for the star wheel base. After cutting the notch and drilling the hole, insert the 5/16" by 3 ¼" black allen head bolts up through the chute and use nuts to hold the bolts in place. Place the star wheel block over the nuts and install the twine guards using the two inner holes of the star wheel block. **The twine guard containing the bale rate sensors will be placed on the right side.** See Step 7 for directions on how to hook-up the star wheel wires.

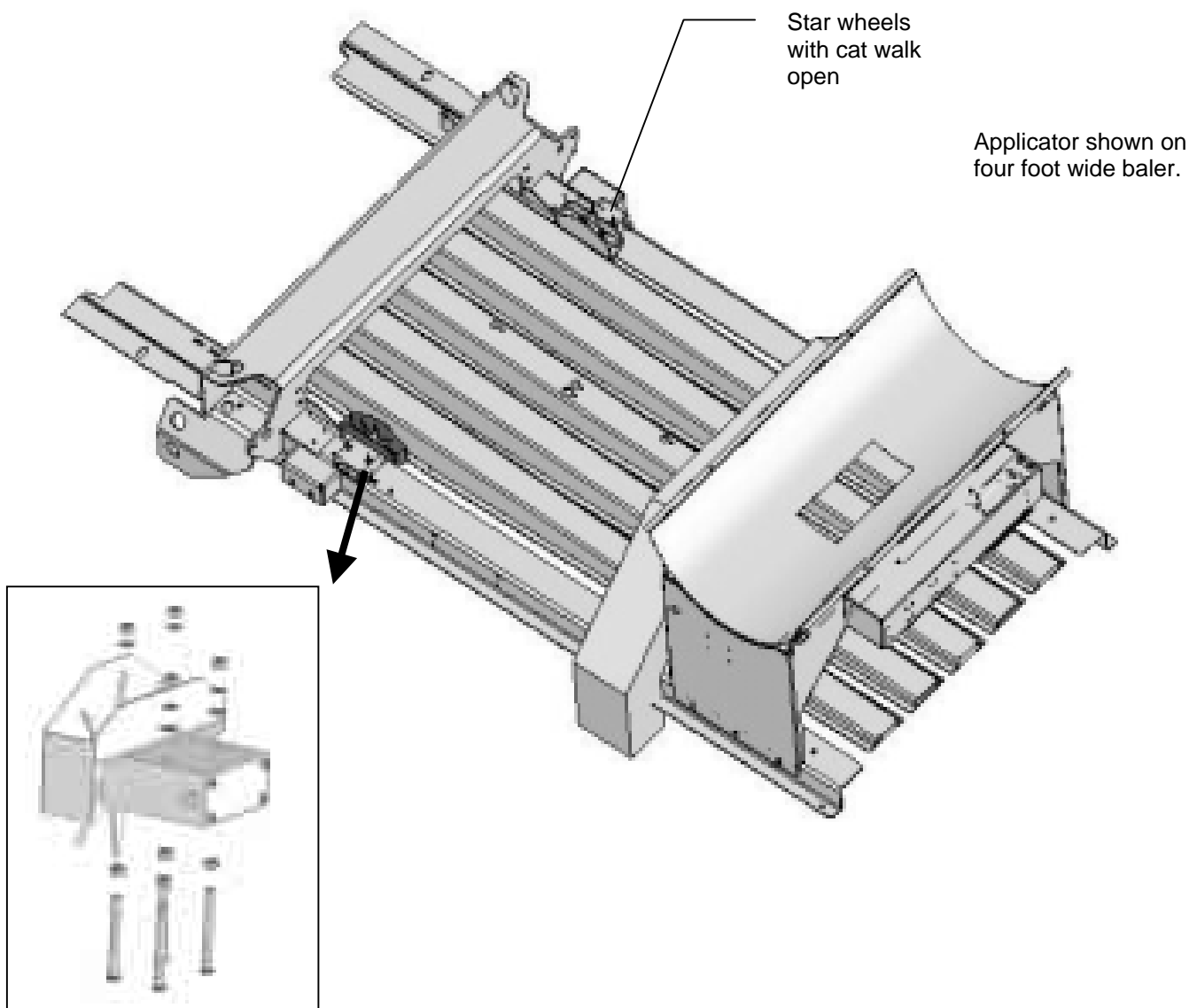

Vicon LB 8200 and LB 12200 & Taarup 6570 – 6690 OC

Mount the tank legs and saddle on the baler as shown below. Insert the two 001-6707BS spacers between the legs and saddle legs. The tank legs bolt to the baler with 1/2" carriage bolts (qty 6). The bolts should be inserted from inside the baler.

The saddle is intentionally tipped forward by 5° so that the tank cap will be parallel to the ground. There is a small cut out "V" where the tank sump fits in the saddle and this cut out should face the back of the baler for the tank to be level when installed on the baler.

Use the template in the back of the manual labeled Vicon large square balers for this installation. The star wheels are to be mounted on top of the baler, just behind the knotters and under the walkway on both sides. Remove the bale from the chute, mount the star wheels flush with the back of the walkway with one star wheel on each side. Mark the holes inside the chamber, and drill the two holes per side, for mounting from inside the chamber. Insert the 5/16" by 3 1/4" black allen head bolts up through the chute and use nuts to hold the bolts in place. Place the star wheel block over the nuts and install the twine guards using the two inner holes of the star wheel block. **The twine guard containing the bale rate sensors will be placed on the right side.** See Step 7 for directions on how to hook-up the star wheel wires.

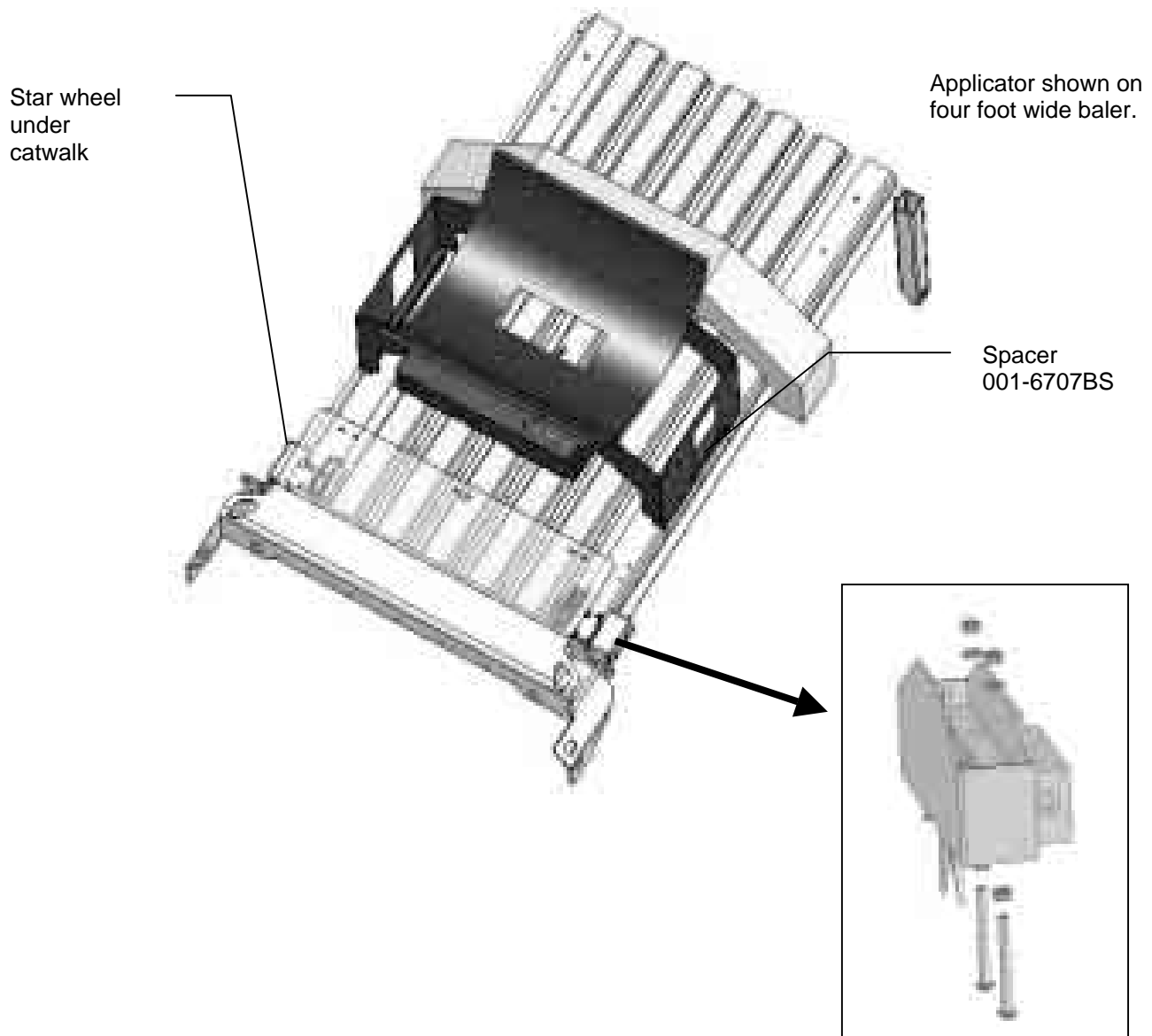

3. INSTALLATION OF THE DRAIN/FILL LINE

- A. Thread $\frac{3}{4}$ " elbow fitting into end of tank.
- B. Run hose from the elbow down the frame to the bottom of the baler.
- C. Drill $\frac{1}{4}$ " holes to accept the valve holder bracket and use $\frac{5}{16}$ " x $\frac{1}{4}$ " self-tapping screws.
- D. Connect valve assembly to other end of hose. Place hose clamps on both ends.
- E. Secure hose to frame using cable locks (**see picture below.**)

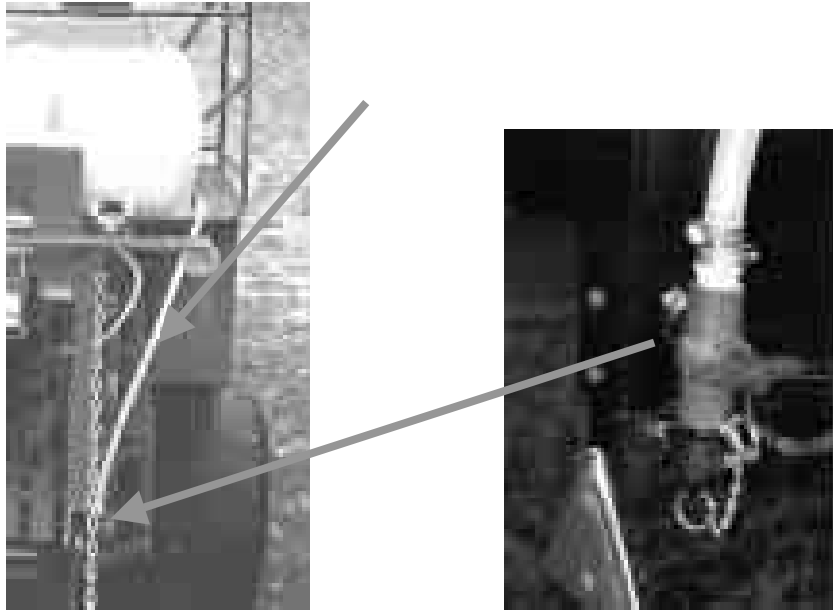

4. INSTALLATION OF THE SPRAY SHIELD

The spray shield assembly is designed to spray the hay evenly as the baler picks it up. A sketch of the spray shield nozzle holder is shown below.

High Output Tips for Rates Requiring 84-632 lbs/hr. (Approximately 21-63 tons/hr)

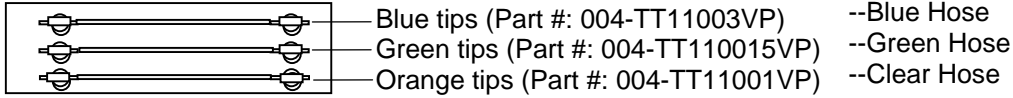

Low Output Tips for Rates Requiring 44-400 lbs/hr. (Approximately 11-40 tons/hr)

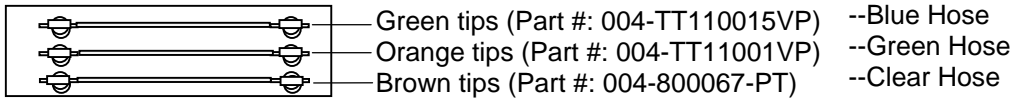

Spray shield showing nozzle placement and tubing.

Installation kit 4438B for Vermeer SQ2731

The spray shield is installed on the gathering fork guard located in the back of the pick up head. Existing bolts are used to fasten the spray shield bracket to the gathering fork guards. Route hoses so they will not interfere with moving parts. This can be checked by rotating the flywheel by hand.

Don't fasten hoses to metal hydraulic lines! A parts breakdown is located in the back of the manual.

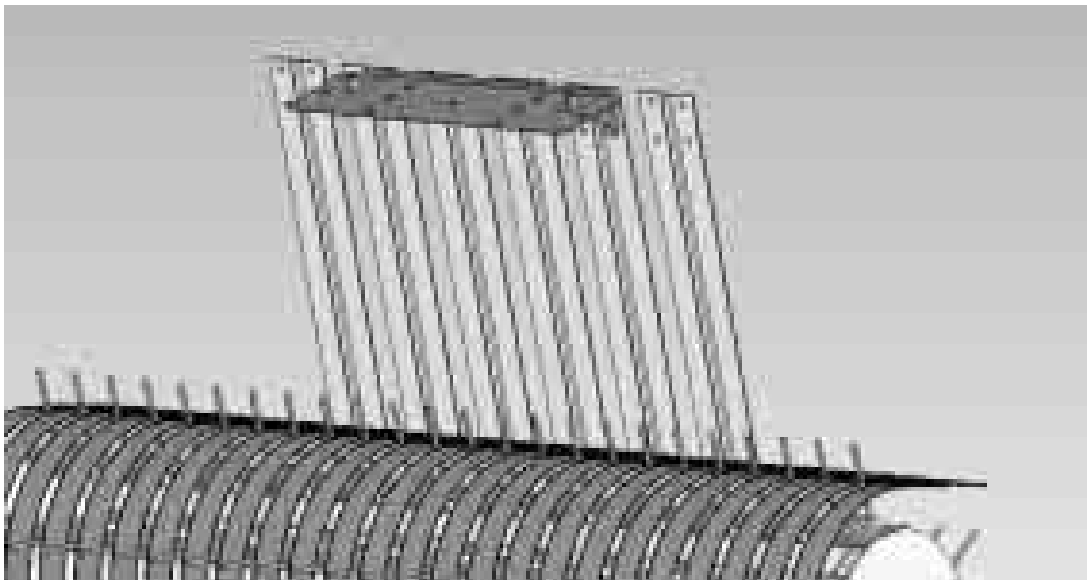

Installation kit 4439B for Vermeer SQ3347

The spray shield is installed on the gathering fork guard located in the back of the pick up head. Existing bolts are used to fasten the spray shield bracket to the gathering fork guards. Route hoses so they will not interfere with moving parts. This can be checked by rotating the flywheel by hand. **Don't fasten hoses to metal hydraulic lines!** A parts breakdown is located in the back of the manual.

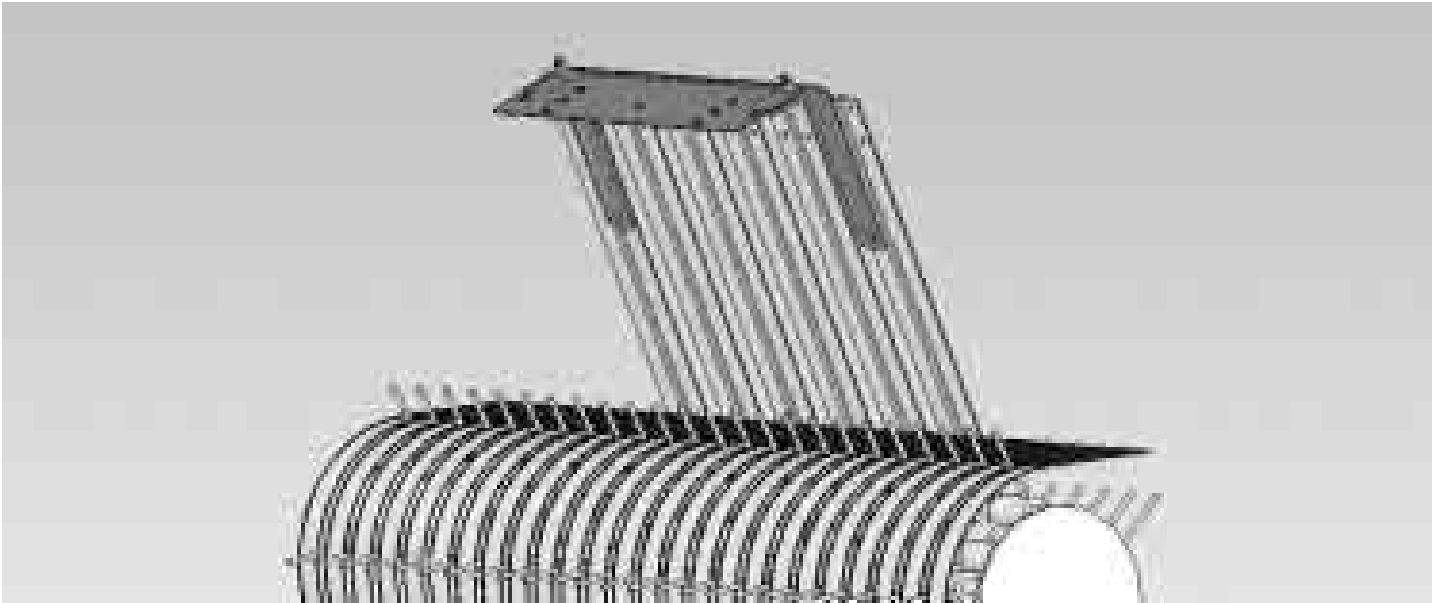

Installation kit 4490B for Case IH 8570 and 8575, Hesston 4750 and 4755, and New Idea 7233 balers

The spray shield holder will be installed underneath the baler's tongue. Bolt the right side up using the existing hole on the bottom lip of the baler. Use the clamp on the left hand side to tighten the shield against the underside of the tongue. Tighten the clamp with the two bolts provided. A parts breakdown of the 4490B is located in the back of this manual.

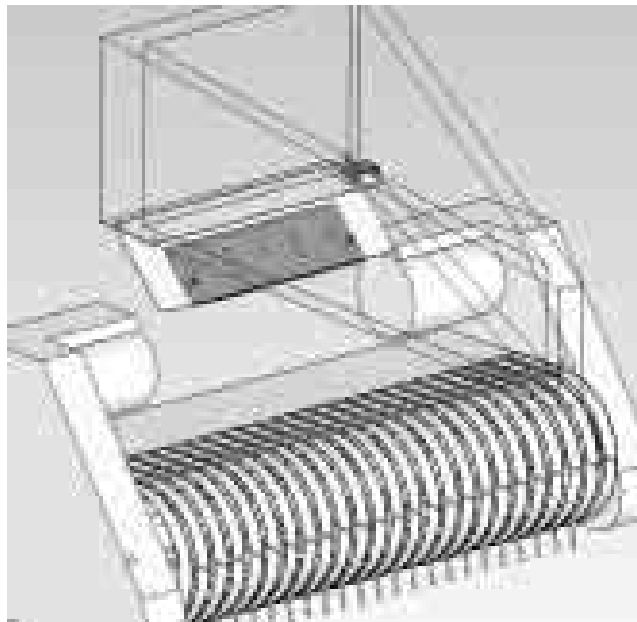

Installation kit 4491B for Hesston 4900 and 4910, Challenger LB44, Case IH 8580 and 8590, and New Idea 7244 balers

Install the spray shield behind the baler's cross channel, which is located on the bottom side of the tongue behind the flywheel. Note the position of the bevel on the spray shield. Clamp the spray shield around the channel using the backing plates and the ¼" by 7" bolts provided. A parts breakdown of the 4491B install kit is shown in the back of this manual.

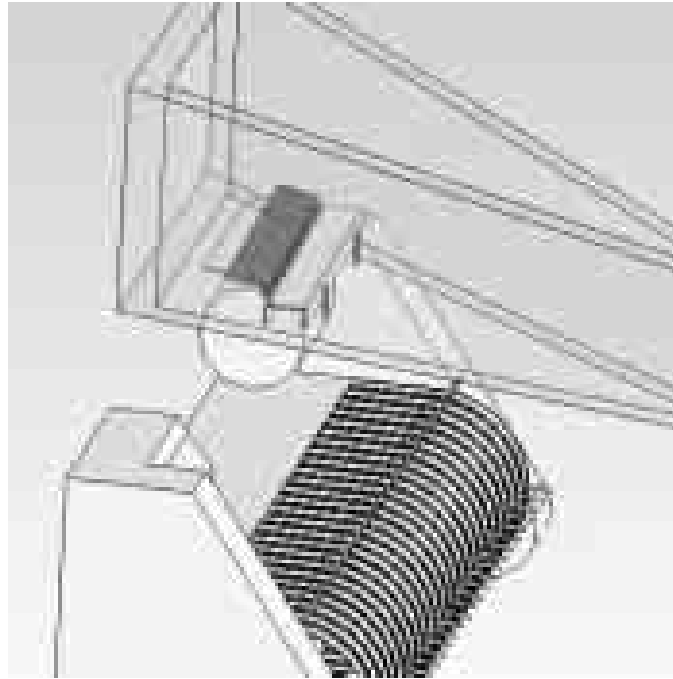

Installation kit 4492B for Hesston 4790, Case IH 8585, Challenger LB34, and New Idea 7234 balers

Remove the two 3/8" carriage bolts that connect the wrapper extension to the angle support on each side. Place the brackets 001-4436DL and 001-4436DR between the angle support and the wrapper extension. Replace the bolts with 3/8" x 1 1/4" carriage bolts, nuts, locks, and flat washers. Before tightening pull down on wrapper extensions so when tightened the bolts are in the top of the wrapper extension slot. Install the wind guard stops 001-4436S as shown below. Two holes will need to be drilled per side. Mount using four 1/4" x 1" bolts, locks and nuts.

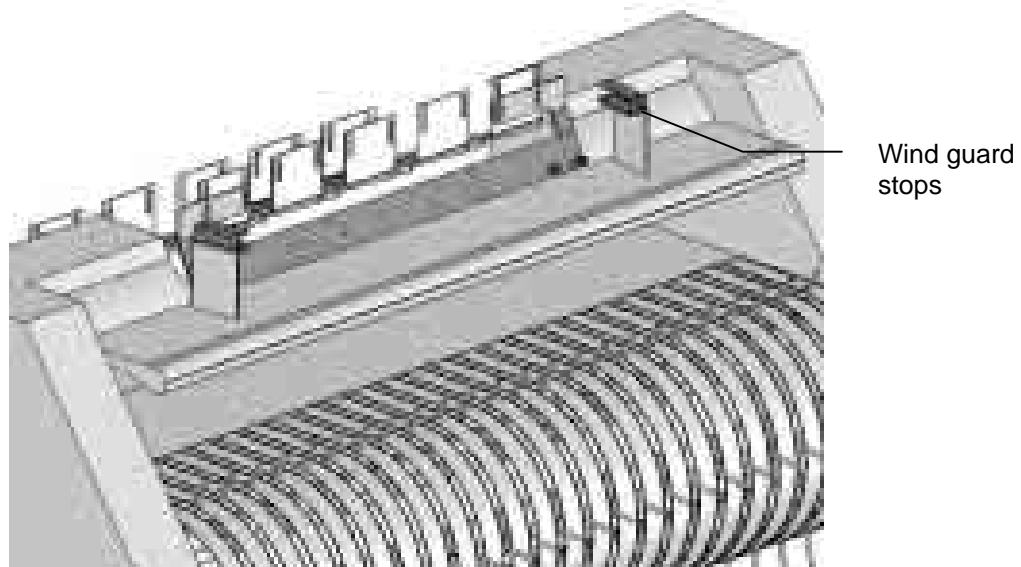

Installation kit 4494B for Challenger LB33, Hesston 4760, and New Idea 7333 balers

Remove the two 3/8" carriage bolts that connect the wrapper extension to the angle support on each side. Place the brackets 001-4436DL and 001-4436DR between the angle support and the wrapper extension. Replace the bolts with 3/8" x 1 1/4" carriage bolts, nuts, locks, and flat washers. Before tightening pull down on wrapper extensions so when tightened the bolts are in the top of the wrapper extension slot. Install the wind guard stops 001-4436S as shown below. Two holes will need to be drilled per side. Mount using four 1/4 x 1" bolts, locks and nuts.

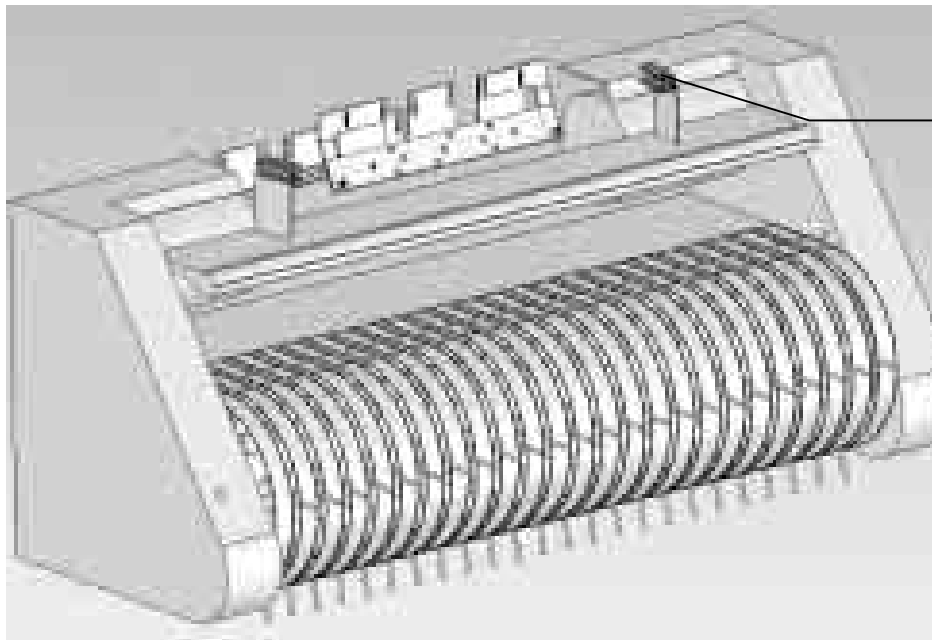

Wind guard stops

Installation kit 4495B for New Holland 590 through BB960A, LBX331 through LBX432 balers and Krone VFS 88 and 128 with cutter

New Holland and Case: Install the spray shield under the tongue of the baler, behind the flywheel. There are two existing bolt holes 6" to 12" above the gathering fork guards, connect the spray shield using these holes. The tips should be pointing to the throat of the baler chamber. A parts breakdown of the 4495B install kit is located in the back of the manual.

Krone: Install the spray shield under the tongue of the baler in front of the flywheel. You will need to drill two holes directly in front of the flywheel to secure the shield on the baler. The tips should be pointing to the throat of the baler chamber. A parts breakdown of the 4495B install kit is located in the back of the manual.

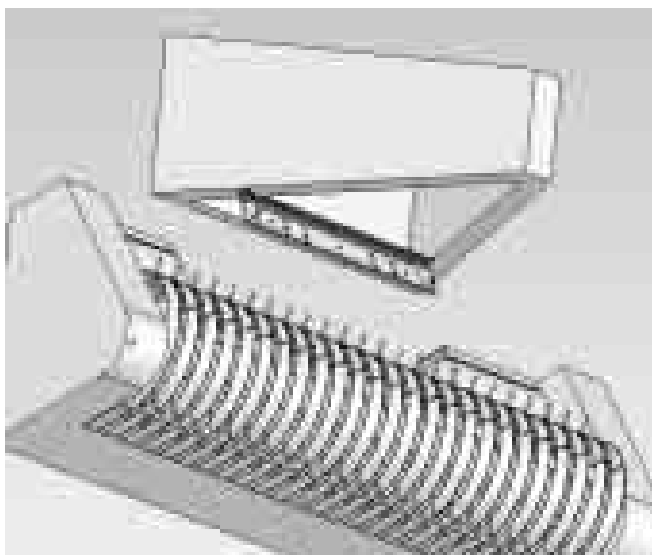

New Holland and Case

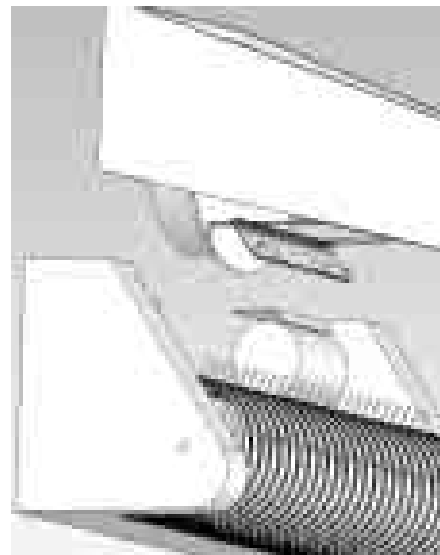

Krone

Installation Kit 4497 for Case IH LBX and New Holland BB balers with roto-cut.

Attach shield to cross member as shown in picture above. Center the shield above the rotor. Four holes will need to be marked and drilled. Use supplied 3/8 x 1 1/4 inch bolts, nuts, and lock washers to attach the shield holders (001-4435E) to the metal cross member directly above the rotor. Attach the spray shield (001-4435ES) to the holders and secure with lynch pins. **The shield is set up for 3X4 balers. Use the inside holes on the shield for 3X3 balers and the outside holes for 3X4 balers.**

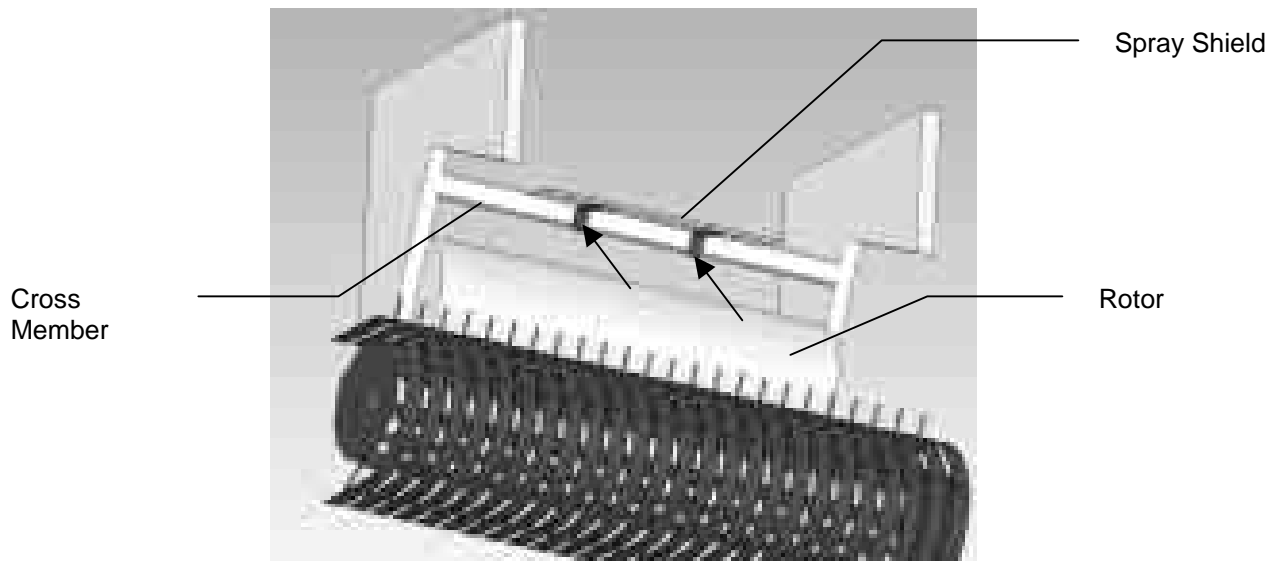

Installation Kit 4498B for Krone VFS 88 and VFS 128 baler

Lower the wind guard of the baler to maximize the installation working space. Locate the guards between the hay intake fingers. Hold the spray shield up so it straddles the top of the guards. Locate the holes on the baler that line up with the spray shield holders. Connect the spray shield to the baler using the existing bolts. Adjust the spray shield so it can be removed and reinstalled freely once the lynch pins are removed.

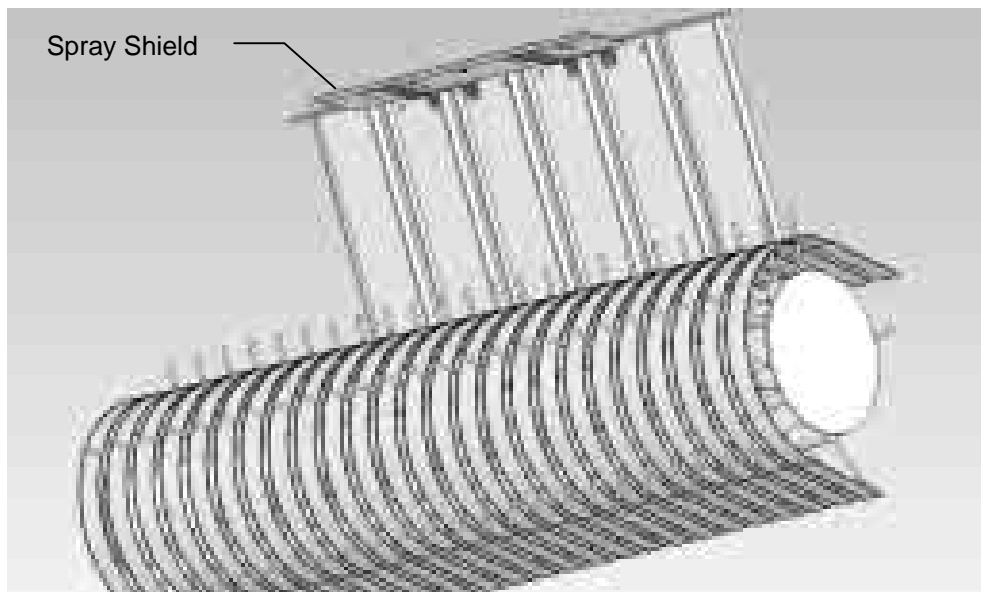

Installation kit 4499B for Claas 2200 baler

Install the spray shield-mounting bracket between the two flat vertical plates above the rotor as indicated in the picture below. Use the existing bolt holes with the hardware from the applicator kit to mount the spray shield bracket to the baler. Fasten the spray shield onto the spray shield bracket already mounted. Route hoses along the spray shield bracket towards the right side of the baler, and then back to the tank. When routing the hose avoid moving parts.

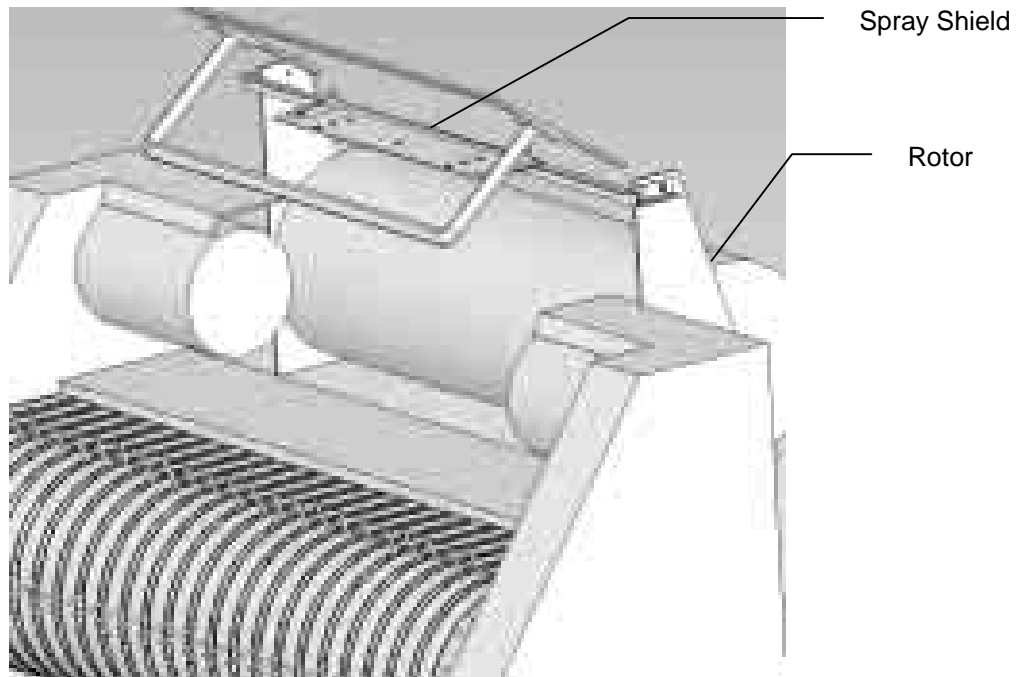

Installation Kit 4500B for Hesston 4760 Baler with Cutter Option

Locate the sheet metal above the top auger. (Figure 1) Locate the two holes through the sheet metal nearest the center of the pickup head. Place two 3/8" x 1 1/4" bolts through the sheet metal with the bolt heads on the bottom side. Place 001-4436CR over the bolts and fasten with 3/8" nuts, locks, and flat washers. Repeat for 001-4436CL on left side of machine. Place spray shield between brackets and tighten hardware.

Figure 1

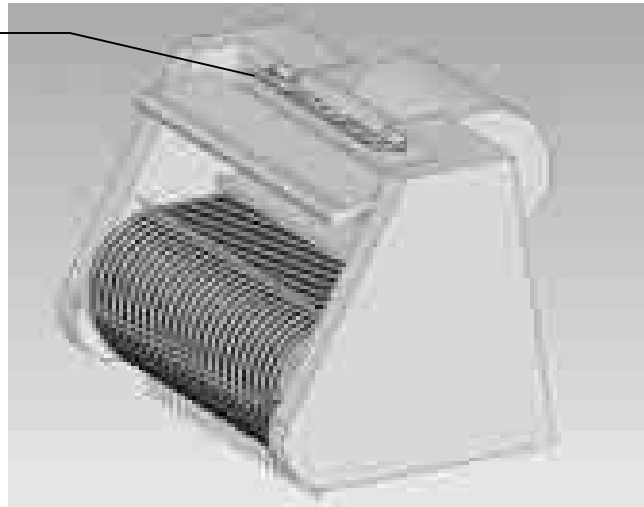

Installation kit 4501B for Hesston 4790 balers with cutter option

4790 cutter balers with top auger. (Figure 1)

Locate the sheet metal above the top auger. Locate the two holes through the sheet metal nearest the center of the pickup head. Place two 3/8" x 1 1/4" bolts through the sheet metal with the bolt heads on the bottom side. Place 001-4436CR over the bolts and fasten with 3/8" nuts, locks, and flat washers. Repeat for 001-4436CL on left side of machine. Place spray shield between brackets and tighten hardware.

4790 cutter balers without top auger. (Figure 2)

Connect spray shield to 001-4436CR and 001-4436CL brackets. Place the assembly across the top of the pickup head so the spray shield is horizontal. Center the shield over the throat of the baler directly above and centered over the bottom augers. Mark the holes on both sides and drill two 7/16" holes on each side. Place two 3/8" x 1 1/4" through the sheet metal bolt heads down. Secure the assembly with 3/8" nut, locks, and flat washers.



Figure 1



Figure 2

Installation Kit 4509 for Claas 2100 Baler with cutter option

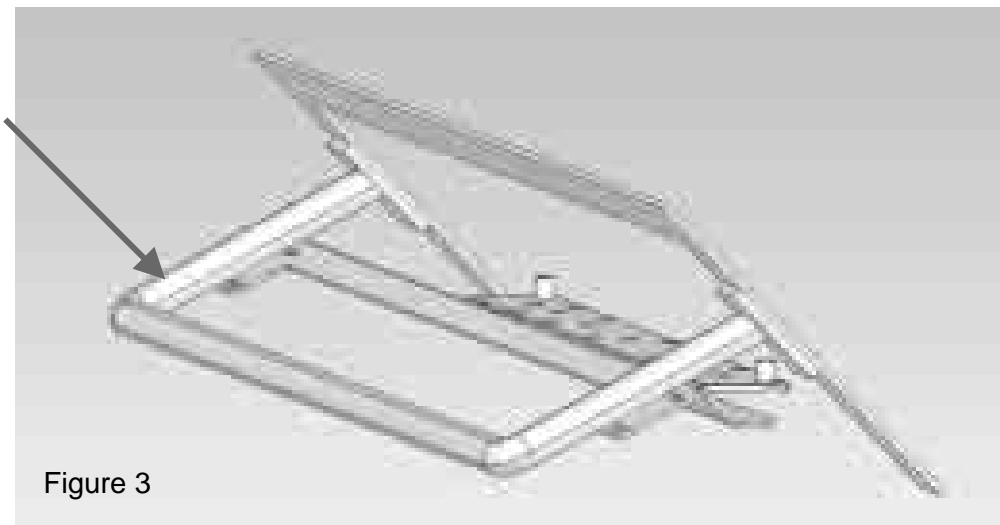
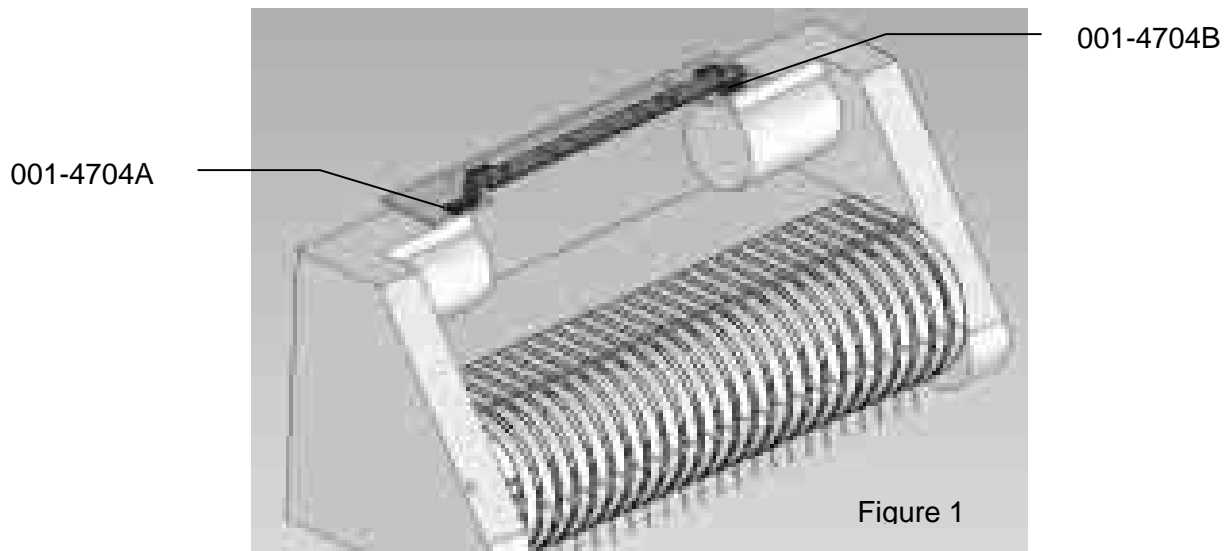

Figure 3

Locate the curved tube (Figure 3) above the auger and rotary cutting system. Attach Shield holder (001-4440A) using the four supplied u-bolts, nuts, flat and lock washers. Slide shield back as far as the baler will allow and tighten down all mounting hardware. Install spray shield (001-4810) and use the two lynch pins (008-4576) to secure.

Installation Kit 4510B for Vicon LB8200 baler & Taarup 6570 – 6570 OC



Locate the sheet metal above the pickup head. (Figure 1) Connect spray shield to 001-4704A and 001-4704B brackets. Place the assembly across the top of the pickup head so the spray shield is horizontal. Center the shield over the throat of the baler directly above and centered over the bottom augers. Mark the holes on both sides and drill two 7/16" holes on each side. Place two 3/8" x 1 1/4" through the sheet metal bolt heads down. Secure the assembly with 3/8" nut, locks, and flat washers.

Installation Kit 4511B for Vicon LB12200 baler & Taarup 6670 – 6690 OC

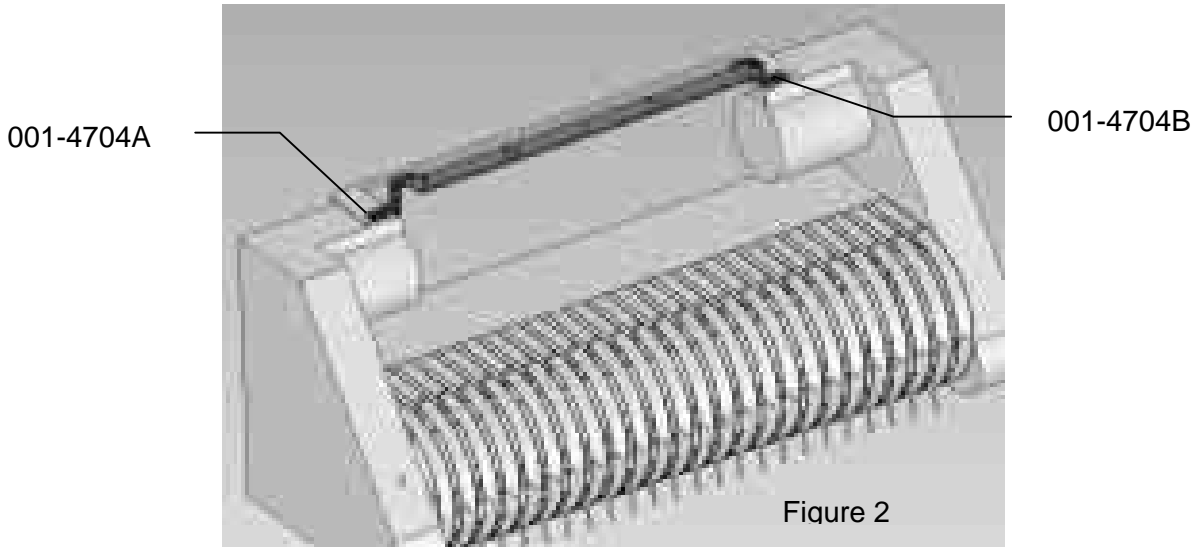

Locate the sheet metal above the pickup head. (Figure 2) Connect spray shield to 001-4704A and 001-4704B brackets. Place the assembly across the top of the pickup head so the spray shield is horizontal. Center the shield over the throat of the baler directly above and centered over the bottom augers. Mark the holes on both sides and drill two 7/16" holes on each side. Place two 3/8" x 1 1/4" through the sheet metal bolt heads down. Secure the assembly with 3/8" nut, locks, and flat washers.

Installation Kit 4514B for Krone 890 – 12130 XC balers

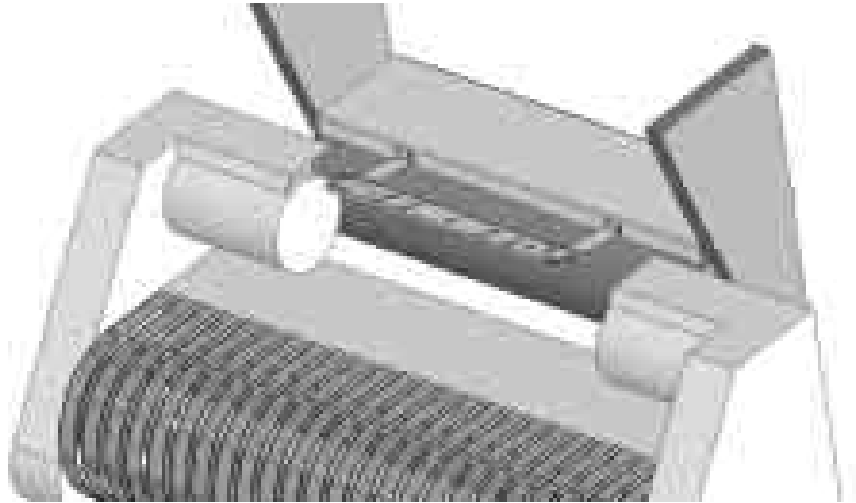

Attach shield to cross member as shown in picture above. Center the shield above the rotor. Four holes will need to be marked and drilled. Use supplied 3/8 x 1 1/4 inch bolts, nuts, and lock washers to attach the shield holders (001-4431K) to the metal cross member directly above the rotor. Attach the spray shield (001-4431B) to the holders and secure with lynch pins. The shield is set up for 3X4 balers. Use the inside holes on the shield for 3X3 balers and the outside holes for 3X4 balers.

Installation Kit 4515B for Krone 890 – 12130 balers

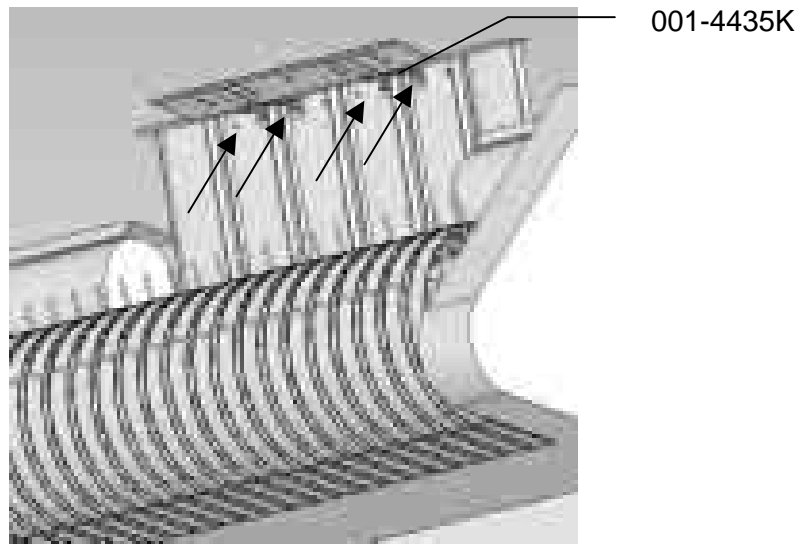

Locate the four center stuffer guards (on narrower models of baler, there may be only four stuffer guards). Remove the nuts and bolts indicated above that fasten the stuffer guards to the cross member above the baler throat. Replace the hardware that you removed with the hardware included in the parts bag (M10x30 bolts, M10 lock washers, and M10 nuts) and bolt the spray shield holder (001-4435K) in place as shown above. Position the spray shield (001-4435ES) on top of the spray shield holders with the pins from the spray shield holder extending through the pipes welded to the spray shield. Adjust the spacing of the spray shield holder as needed and tighten the hardware.

Installation Kit 4518B for Agco large square balers without cutter

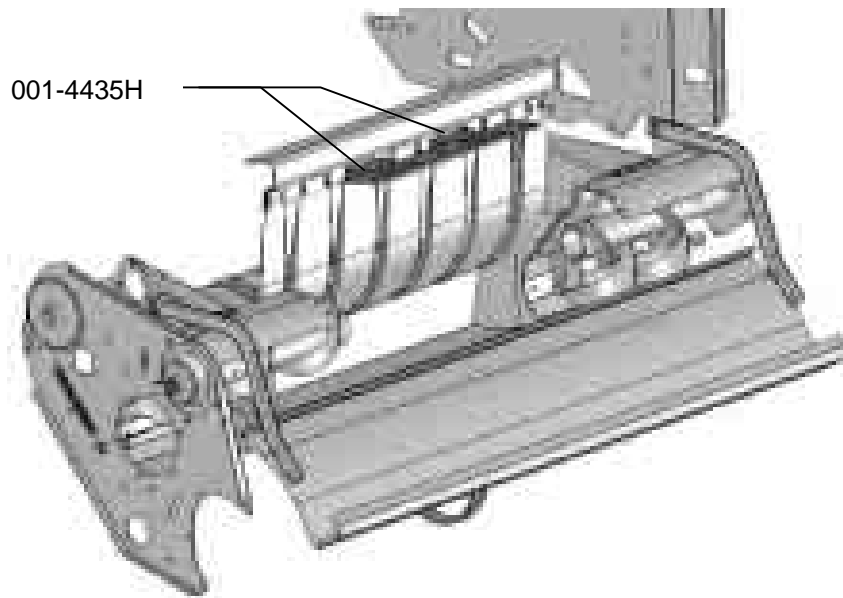

Remove the four bolts attached to the wrapper stripper plates as shown above. Replace with the four supplied $3/8 \times 1\ 1/4$ carriage bolts, nuts, locks, and flat washers. Mount the spray shield holders (001-4435H) and loosely tighten down hardware. Install spray shield and secure with the two supplied lynch pins. Tighten all hardware.

Installation Kit 4519B for Agco large square balers with cutter

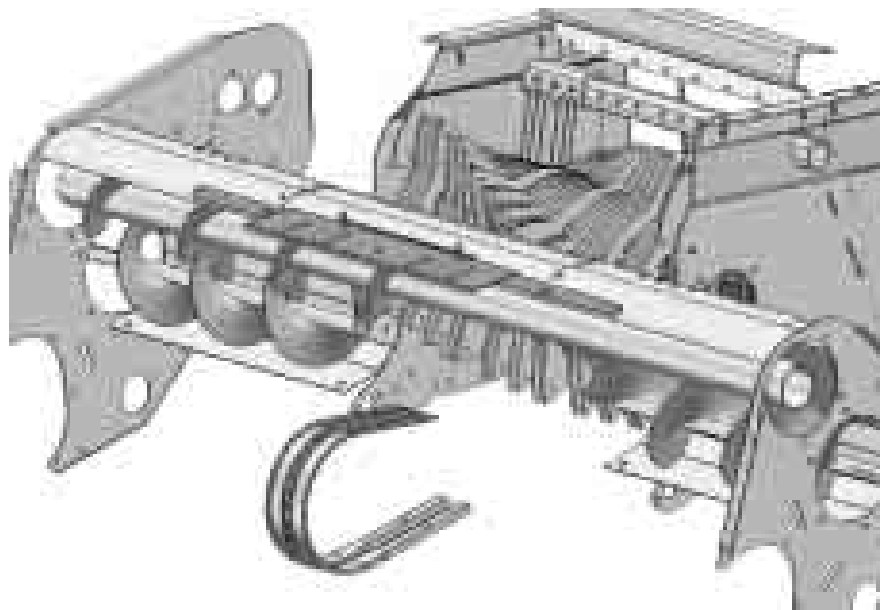

Locate bottom hole on each side of center insert over top auger and bolt spray shield and mounting bracket into place using the $3/8 \times 1\ 1/4$ carriage bolts, nuts, locks, and flat washers. Use the inside slots on 3x3 balers and the outside slots on 3x4 and 4x4 balers.

5. PLUMBING

- A. Locate the three ¼" hoses colored clear, blue, and green. The pumps will need to be connected to specific tips so the pump numbers are as follows: Pump 1 is closest to the filter bowl pump 2 is in the middle and pump 3 is the outside pump.
- B. Use warm soapy water when connecting the hose to the pumps located inside the pump plate and install hose clamps at the same time. Because all nozzles on the spray shield are different, the operator will need to install pump 1 to the orange tips using the clear hose, pump 2 to the green tips using the green hose and pump 3 to the blue tips using the blue hose.
- C. **KEEP HOSE AWAY FROM: MOVING PARTS, SHARP METAL, AND HYDRAULIC LINES. WORKING TEMPERATURE FOR THE HOSE IS 140 °F AND UNDER.**
- D. Tie the hose down at secure locations on the baler using the enclosed tie straps and cable clamps.

High and Low Output Tips

Your baler comes with two sets of tips: a low set and a high set. The high set comes factory installed.

-The high set will cover outputs of 84 to 632 lbs/hr (Apprx. 21-63 tons/hr) Install the following tips for high output:

- Clear hose to orange tips
- Green hose to green tips.
- Blue hose to blue tips.

-The low set will cover outputs of 44 to 400 lbs/hr (Apprx. 11-40 tons/hr) Install the following tips for low output:

- Clear hose brown tips.
- Green hose to orange tips.
- Blue hose to green tips.

****Refer to Tip Output under APPLICATION RATE of the control unit to calibrate system.**

6. WIRING THE STAR WHEEL HARNESS

First, remove the cover from the star wheel block and use a ¼” nut driver to remove the nut from the electronic swivel. Next, run the star wheel sensor wire through the black grommet and place the eye terminal on the star wheel sensor. Tighten the eye loop with the nut on the sensor and put the star wheel cover back on the base. Next, tighten the grommet to form a tight seal around the wire. Once the star wheel connection is complete, run the wires along the baler frame to the pump plate. (See wiring installation on the following page.) The baler mounted processor is located underneath the pump holder.

7. INSTALLATION OF BALE RATE SENSORS

The bale rate sensors will be factory installed on the right side twine guard in the correct position. The sensor with the longer sensor wire should say “FRONT”, which indicates it should be placed in the front sensor hole. The sensor wire with the shorter wire should say “BACK.” The tip of the sensor should be placed no more than ¼” away from the star wheel teeth and no less than 1/8” from the star wheel teeth. Connect the bale rate sensor wires to the baler mounted processor located on the underside of the pump plate. Each sensor will have an LED light located by the wire connection by the star wheel. Once the unit is powered up spin the wheel and make sure that both led lights turn on and off. If they don't turn on and off, adjustments may need to be made.

8. INSTALLATION OF CONTROLS

Use the four mounting screws to mount the round base in a convenient area in your cab or on your fender. If unit is mounted on fender it will need to be removed at night and stored in a clean, dry area. Use the Ram mount swivel-positioning nut to tighten the entire assembly. Adjust it so that you can view the entire screen and be able to use the touch screen without interfering with other tractor functions.

9. INSTALLATION OF DISPLAY CABLE HARNESS

On the bottom of the touch screen display you will find the main display wire plug. The harness (006-4660N) will need to be attached to this plug and run through the cab towards the hitch where it will connect with its matching harness (006-4660L) from the baler mounted processor.

10. MAIN WIRING HARNESS AND POWER CORD INSTALLATION



Route cords 006-4660L and 006-4660K along this path or similar inside of the baler. Keep cords away from moving parts and hydraulic hoses. Secure with existing cable clamps or use cable ties.

WIRING INSTALLATION

1. Locate the power harness.
2. Connect the power harness (006-4640A) to the battery (12 volt) using the red wire with fuse to the positive side and the black wire to the negative.
 - a. **The power harness must be connected to the battery!** The unit will draw more amps than convenience outlets can handle. Any modifications of the power harness will void systems warranty. IF MODIFICATIONS ARE REQUIRED CONTACT HARVEST TEC FIRST!
 - b. **This unit will not function on positive ground tractors.**
 - c. **If the unit loses power while operating it will not keep track of accumulated pounds of product used.**
3. The power harness(006-4640A) will run from the tractor battery to the hitch. The power harness (006-4660K) will connect to the tractor power harness (006-4640A) at the hitch. Run the Communication harness (006-4660N) from the cab to the hitch. This wire will connect to the Communication harness (006-4660L). These wires will run together to the Baler Mounted Processor (006-4671LS).
4. Connect Flow Meter (006-4725A) to the Baler Mounted Processor.
5. Connect Pump Harness (006-4660Z) the Baler Mounted Processor.
6. If you have the optional Hay Indicator kit connect it to the Baler Mounted Processor.
7. Attach moisture cable (006-4640E) to Baler Mounted Processor.
8. Install Baler Mounted Processor in pump plate using 5/16" lock, nut and flat washers.



NOTE: The plugs on the Baler Mounted Processor must face down. Failure to mount correctly will void systems warranty.

SYSTEM WIRING DIAGRAM

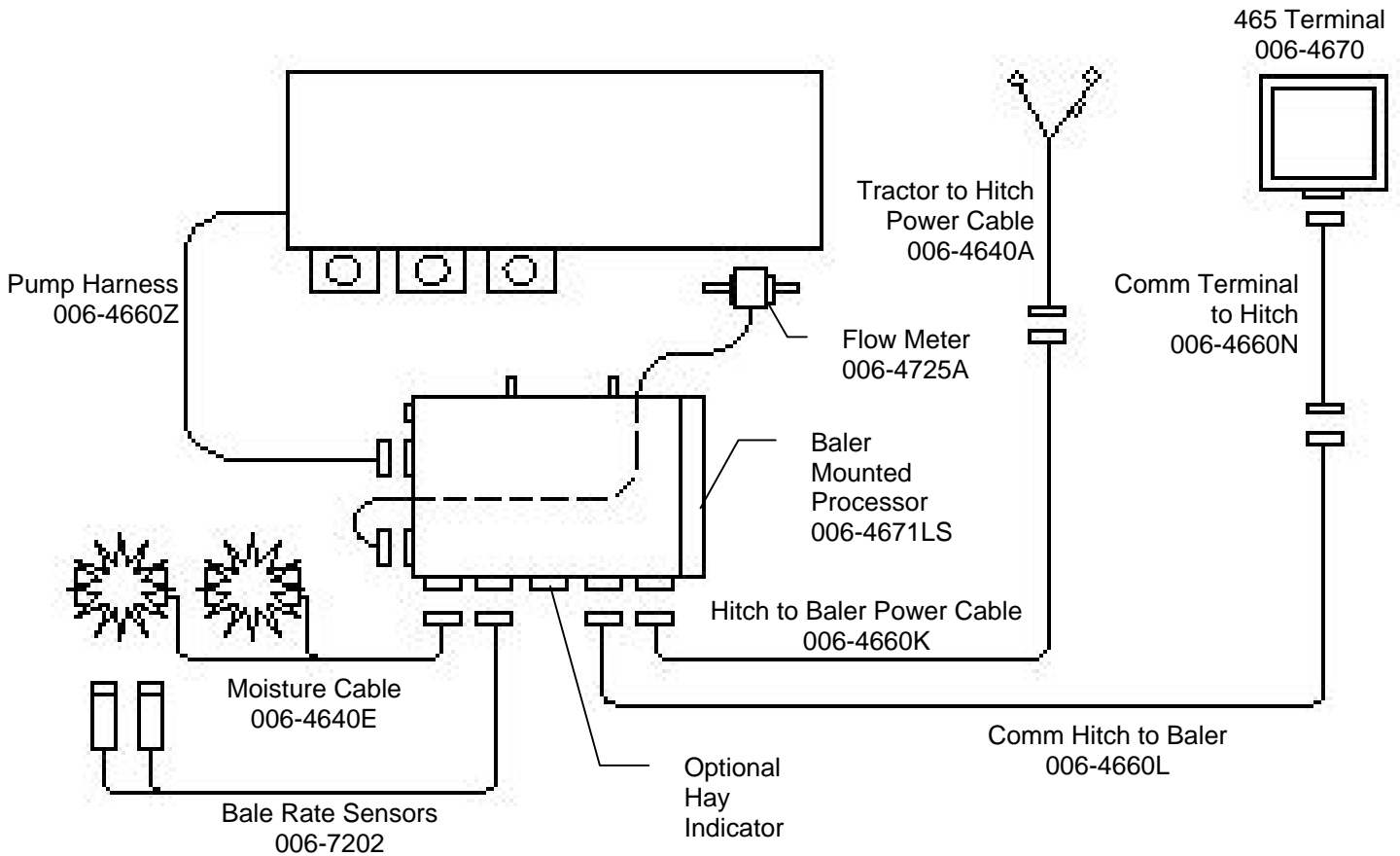

11. DESCRIPTION OF BUTTONS

This system is calibrated for use with Harvest Tec buffered propionic acid. The use of other products can cause application problems and damage to system components. It is designed to apply rates of 44 to 632 pounds of acid per hour and read moisture levels of 10 to 70 percent. The 465 monitor will allow you to set your bale size, weight, single bale formation time, moisture levels and application rates. The automatic mode will automatically adjust the application rates as the moisture level changes. Manual mode will allow you to control the application rates on the go.

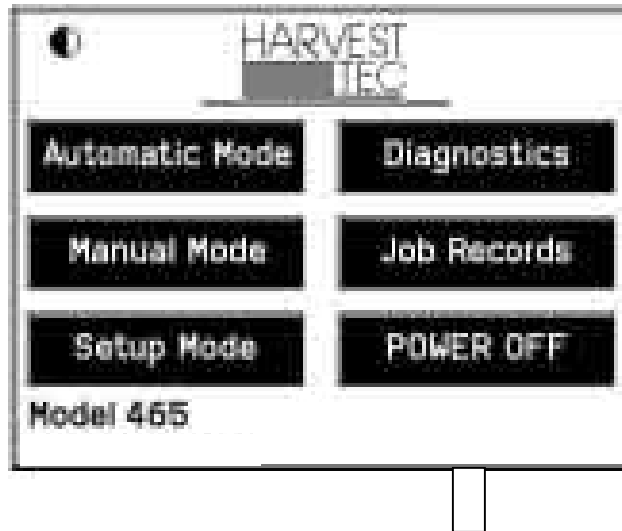

AUTOMATIC MODE This mode allows you to use all of the applicators features such as adjusting preservative application on the go and counting total pounds of product used.

MANUAL MODE Allows operator to manually turn pumps on and off. This mode also has moisture content displayed. Use this mode to prime pumps.

SETUP MODE This mode allows the operator to adjust bale rate and application rate settings and view or change tip selection.

DIAGNOSTICS Allows operator to automatically check performance and output of pumps as well as set the date and time.

JOB RECORDS Keeps track of up to 63 jobs with total product used, average moisture content, tons baled, and date of baling.

POWER OFF This key turns the unit off. Press anywhere on the right side of the screen to turn the unit on followed by pressing the "Press to Start" key within 5 seconds.



CONTRAST This button is your contrast control. Press this button to lighten the screen. When the screen reaches its lightest point, pressing again will return to the darkest setting. Fine tuning the contrast can be accomplished by turning the knob on the bottom right side of the enclosure.

12. FIRST TIME AND ANNUAL START UP INSTRUCTIONS

AFTER INSTALLATION THE UNIT MUST BE CHECKED OUT BEFORE FIELD OPERATION!!

CHECKING AND PRIMING THE PUMPS

1. Put 10 gal of water in tank and turn main ball valve on.
2. Inspect for any leaks or drips at this time. If any are found tighten or replace area or fitting.
3. **Turn controller on** (push anywhere on the screen followed by pressing on the press to start key).
4. Press the SETUP MODE key. (**See page 35**) **Select Sensors are: OFF** to disable bale rate sensors. Make sure the AVG Bale Weight is 1500 lbs and the AVG Baler Length is 96 in. and EST Baling Time is 60 sec. Press the MAIN MENU key to return to the opening screen.
5. Press the MANUAL MODE key.
6. The screen shown below should appear.
7. The rates listed below are for Harvest Tec buffered propionic acid. Other products will need to be collected and weighed to assure proper performance is achieved.

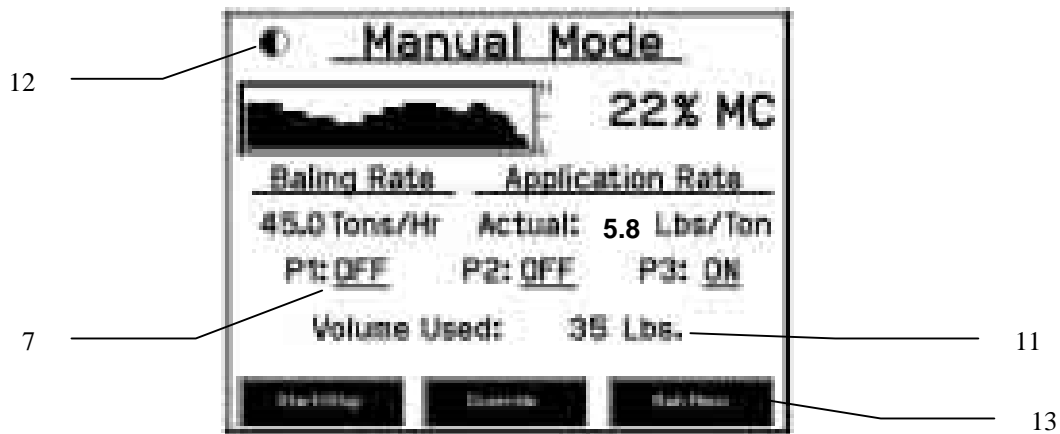

8. NOTE: THE SYSTEM COMES WITH THE HIGH TIPS ALREADY INSTALLED ON THE SPRAY SHIELD. TEST SYSTEM WITH TIPS YOU WILL USE MOST OFTEN.

- **With low tips in:** Turn pump 1 on (P1). To do this press the underlined area on the screen which says OFF. The application rate should then read between .7 – 1.2 Lbs/Ton. Ideally, at 13.5 volts, the rate would read 1.0 Lbs/Ton.
 - Repeat the process for pumps 2 and 3 (P2 and P3). The application rate should read between 1.7 – 2.4 Lbs/Ton and 2.5 – 3.5 Lbs/Ton respectively. Ideally, at 13.5 volts, the rate for pump 2 would be 2.0 Lbs/Ton; pump 3 would be 3.0 Lbs/Ton.
 - **With high tips in:** Turn pump 1 on (P1). To do this press the underlined area on the screen which says OFF. The application rate should then read between 1.3 – 1.9 Lbs/Ton. Ideally, at 13.5 volts, the rate would read 1.6 Lbs/Ton.
8. Repeat the process for pumps 2 and 3 (P2 and P3). The application rate should read between 2.6 – 3.6 Lbs/Ton and 4.9 – 6.8 Lbs/Ton respectively. Ideally, at 13.5 volts, the rate for pump 2 would be 3.1 Lbs/Ton; pump 3 would be 5.8 Lbs/Ton.
 9. This process will also be used to prime the pumps whenever needed.
 10. While running pumps check for a good spray pattern out of the respective tips and verify that no parts of the system are leaking.
 11. While doing these tests the Volume Used on the bottom of the screen should be counting up, this verifies that the flow meter is functioning.
 12. This button is your contrast control. Press this button to lighten the screen. When the screen reaches its lightest point, pressing again will return to the darkest setting.
 13. Press the MAIN MENU key to return to the initial start up screen.

NOTE: It is recommended that the system be run with the bale rate sensors on. Press the SETUP MODE key and turn the bale rate sensors back on for normal operation. (Also see Baling Rate to adjust bale weight, length, and time.)

13. SETTING UP SYSTEM FOR INITIAL USE

In this mode you will setup your initial application rate and baling rate.

APPLICATION RATE

After pushing the SETUP MODE key in the Main Menu screen, the top left screen will show on the display:

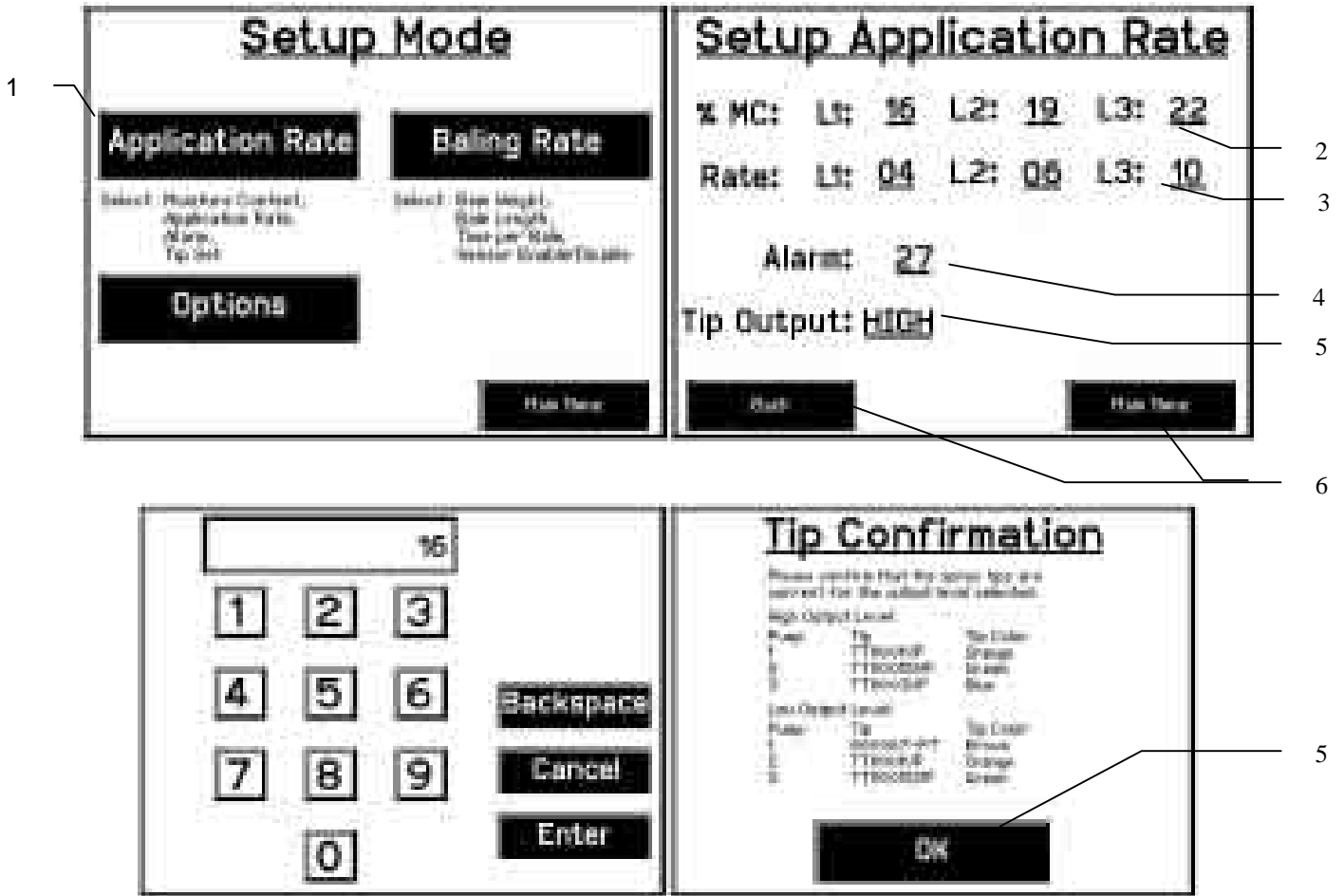

1. On this screen the operator will press the APPLICATION RATE key. Once pressed the SETUP APPLICATION RATE screen will be shown. (Top right picture)
2. Press any of the underlined numbers to the right of %MC to adjust their figures. The key pad shown on the bottom left will display. Remember level 1 must be lower than level 2 and level 2 must be lower than level 3. Harvest Tec products recommend set points of 16, 19 and 22% MC levels. These are preset from the factory. Press ENTER to return to previous screen.
3. To change rate of chemical application press any of the underlined numbers to the right of RATE:. The key pad shown on the bottom left will display. Remember level 1 must be lower than level 2 and level 2 must be lower than level 3. Harvest Tec products recommend rates of 4, 6, and 10 lbs/ton. These rates are preset from the factory. Press ENTER to return to previous screen. **IT IS THE OPERATORS RESPONSIBILITY TO FOLLOW THE RECOMMENDATIONS OF THE PRESERVATIVE. ONLY THE OPERATOR CAN APPLY THE PROPER RATE.**
4. To set the alarm press on the underlined area and set the level at which you want the alarm to activate. To turn the alarm off, set level above 80.
5. To change the tip output setting to either low or high, press the underlined word to the right of Tip Output:. In the TIP CONFIRMATION screen the operator can verify and change tip selection. After tips have been verified or changed press the OK key to return to the previous screen.
6. Next press the BACK key found on the bottom left hand figure of the screen to return to Setup Mode screen or press the MAIN MENU key on the bottom right hand figure of the screen to return to the opening screen.

BALING RATE

After pushing the SETUP MODE key in the Main Menu screen, the top screen should appear:

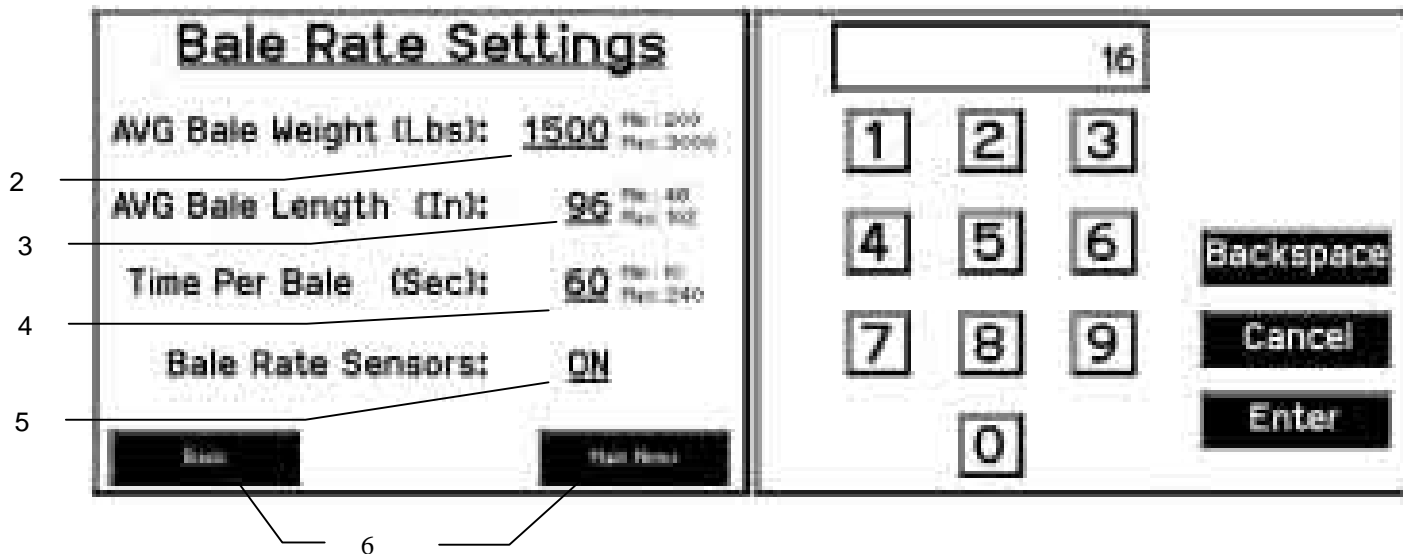
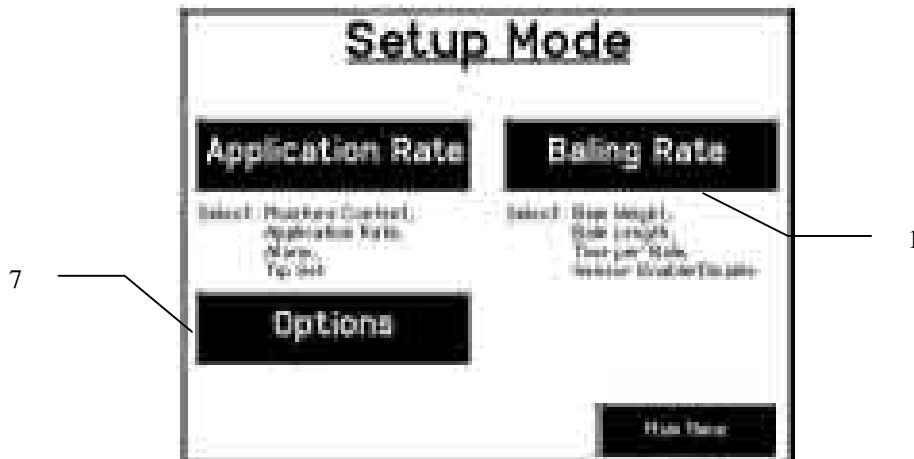

1. On this screen the operator will press the BALING RATE key. This screen is shown on the bottom left picture shown above.
2. Press the underlined number to the right of AVG Bale Weight (Lbs): to adjust the weight of your bales. The key pad shown on the right side will display. Press any number combination in this screen within the min/max limits. Press the ENTER key to save this information. The information will remain until it is changed again.
3. Press the underlined number to the right of AVG Bale Length (In): to adjust the length of your bales. The key pad shown on the right side will display. Press any number combination in this screen within the min/max limits. Press the ENTER key to save this information. The information will remain until it is changed again.
4. Press the underlined number to the right of EST Baling Time (Sec): to adjust the time it takes to make a bale. The key pad shown on the right side will display. Press any number combination in this screen within the min/max limits. Press the ENTER key to save this information. The information will remain until it is changed again.
5. If the unit will be run with the bale **sensors on**, then the bale weight and length will need to be inputed. When the **sensors are: on**, the applicator will calculate your tons per hour. When the **Sensors are: off** (as shown above), a constant tons per hour (your inputed bale weight and time) will be used. Press the underlined word to toggle between on or off.
6. Next press the BACK key found on the bottom left hand of the screen to return to the Setup Mode screen, or press the MAIN MENU key on the bottom right hand of the screen to return to the opening screen.
7. Press the OPTION key to adjust the touchscreen between metric and standard units and languages.

OPERATING INSTRUCTIONS

Auto mode will automatically apply product based on both hay moisture content sensed by the star wheels and the operator's presets. (See SETTING UP SYSTEM FOR INITIAL USE to change any of these settings). **Manual mode will apply preservative to the hay at a fixed rate regardless of the moisture content.**

AUTOMATIC MODE

After pushing the AUTOMATIC MODE key in the Main Menu screen, the following screen should appear:

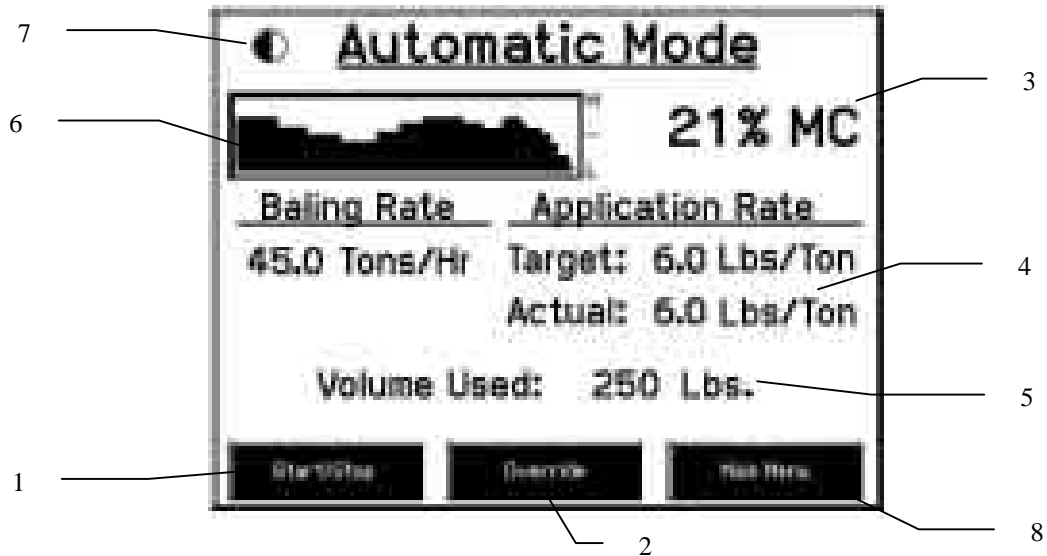

1. Push the START/STOP key to pause the unit while in operation.
2. Push the OVERRIDE key to turn on all three pumps at the same time for full output of the system. Use this mode when going through a short area of wet crop.
3. The moisture content is shown in the upper right hand corner.
4. Baling Rate and Application Rate are shown in the middle. The operator sets the target application rate in the setup mode; the actual rate should be within +/- one pound when running. The baling rate is also set in Setup Mode.
5. Volume used shown at the bottom of the screen will show accumulated pounds of preservative used on the go. This number will reset at power down, but remains in the job record screen. **NOTE: Initial start-up requires pressing the New Job key in the Job Records screen in order for Volume Used accumulation to be recorded. This only needs to be done once on initial start-up of system and not every time the system is started for operation.** (See JOB RECORDS screen)
6. The graph shows the moisture trend from the past 90 seconds in 3 second intervals.
7. This button is your contrast control. Press this button to lighten the screen. When the screen reaches its lightest point, pressing again will return to the darkest setting.
8. Press the MAIN MENU key to return to the opening screen.

MANUAL MODE

After pushing the MANUAL MODE key in the Main Menu screen, the following screen should appear:

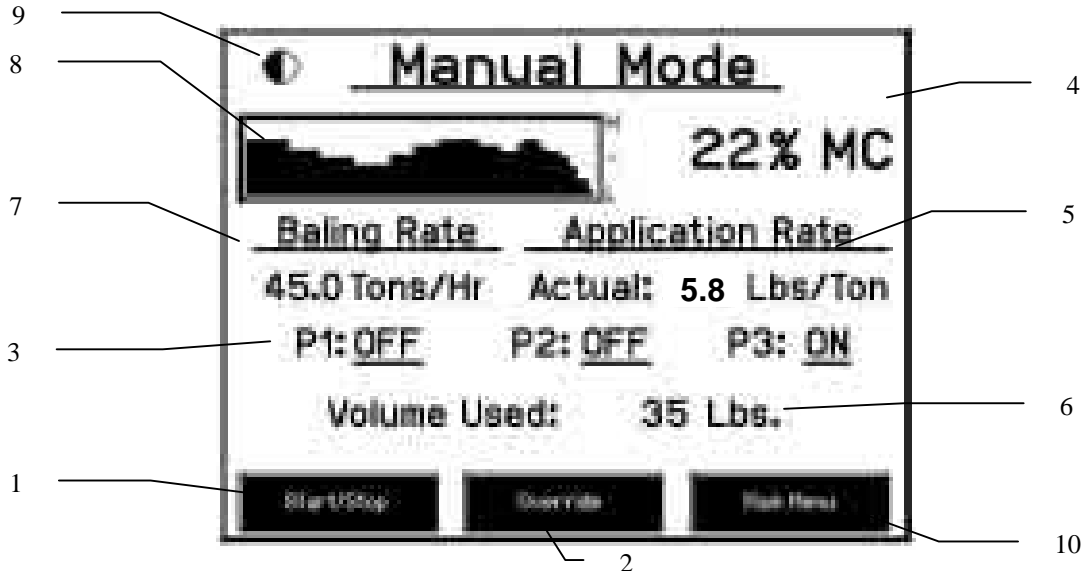

1. Push the START/STOP key to pause the system while in operation.
2. Push the OVERRIDE key to turn on all three pumps at the same time for full output of the system. Use this mode when going through a short area of wet crop.
3. In Manual Mode you can turn the pumps on or off by pressing the underlined area next to the pump numbers. In Manual Mode (regardless of moisture, tons per hour or bale weight) the outputs of the pumps are fixed rates as follows:

Low output tips:

Pump 1 = 45 LBS/HR
Pump 2 = 90 LBS/HR
Pump 3 = 135 LBS/HR

High output tips:

Pump 1 = 75 LBS/HR
Pump 2 = 140 LBS/HR
Pump 3 = 265 LBS/HR

4. The moisture content is shown in the upper right hand corner.
5. Baling rate and Application rate are shown in the middle. The output of a pump can be checked by dividing the preset output (shown in step 3) by the baling rate. For example, if you have the high output tips in and are running pump three by itself, your output is 265 lbs/hr. Given the baling rate shown on the above screen (45.0 tons/hr), the application rate should be about 5.8 lbs/ton (265lbs/hr divided by 45.0 tons/hr).
6. Volume used shown at the bottom of the screen will show accumulated pounds of preservative used on the go. This number will reset at power down, but remains in the job record screen. **NOTE: Initial start-up requires pressing the New Job key in the Job Records screen in order for Volume Used accumulation to be recorded. This only needs to be done once on initial start-up of system and not every time the system is started for operation.** (See JOB RECORDS screen)
7. The baling rate is set in the Setup Mode menu.
8. This graph shows the moisture trend from the last 90 seconds of baling (one reading every 3 seconds).
9. This button is your contrast control. Press this button to lighten the screen. When the screen reaches its lightest point, pressing again will return to the darkest setting.
10. Press the MAIN MENU key to return to the opening screen.

JOB RECORDS

After pushing the JOB RECORDS key in the Main Menu screen, the following screen should appear:



1. The job number will be displayed in the top left corner and will move to the next job when the NEW JOB key is pressed. The current job being viewed will always read "Job #: 0". Product used and average moisture content will be reset when the NEW JOB key is pressed. The job records screen will store up to 63 jobs and will allow you to access previous jobs by using the up and down arrows found on the right side of the screen.
2. Scrolling through previous jobs is done by pressing the UP or Down keys.
3. **Every time the NEW JOB key is pressed the accumulated pounds on auto and manual modes will be reset to zero.** After 63 jobs have been stored, the next time the NEW JOB key is pressed the system will start over with job one and the old job will be replaced.
4. To return the opening screen, press the MAIN MENU key.

NOTE: Initial start-up requires pressing the New Job key in the Job Records screen in order for Volume Used accumulation to be recorded. This only needs to be done once on initial start-up of system and not every time the system is started for operation.

NOTE: Total Baled will not accumulate with the bale rate sensors off.

DIAGNOSTICS

After pushing the DIAGNOSTICS key in the Main Menu screen, the following screen should appear:

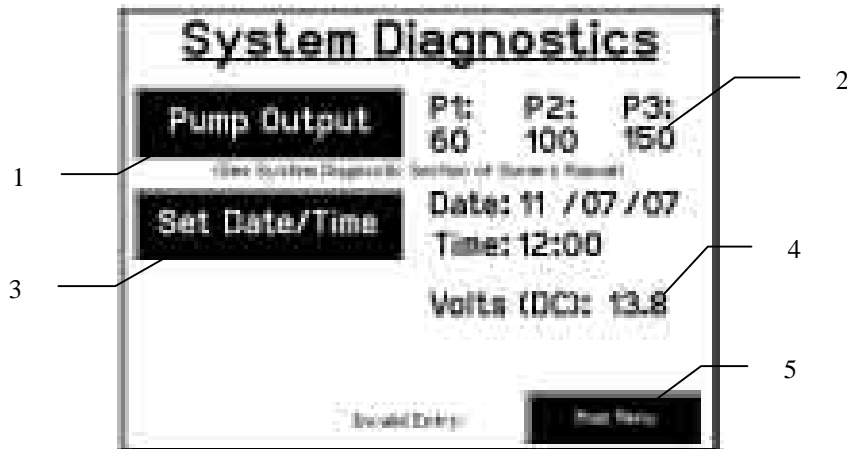

The diagnostic mode will automatically check the pump output and performance of the three pumps. It is recommended to use this mode daily to ensure proper system performance.

Acceptable ranges for output:

Low output tips:

Pump 1 = 38 - 53 LBS/HR
Pump 2 = 76 - 105 LBS/HR
Pump 3 = 115 - 160 LBS/HR

High output tips:

Pump 1 = 64 - 88 LBS/HR
Pump 2 = 119 - 165 LBS/HR
Pump 3 = 225 - 312 LBS/HR

- Once the screen is displayed, press the PUMP OUTPUTS key.
The machine will cycle all three of the pumps for 15 seconds. After the cycles are complete, the system will display a number next to each pump number.
- If the system displays within the listed range.**
 - The system is operating correctly.**If the system displays higher than the listed range, some common problems could be:**
 - Leak in line. Inspect lines thoroughly.
 - Tip missing. Check for lost or broken tip on spray shield.
 - Tip worn. Replace tip.
 - High tractor voltage.**If the system displays lower than the listed range, some common problems could be:**
 - Make sure there is preservative in the tank and ball valve is in the open position.
 - Air in lines. Pump will not prime. Check for leak in lines, or defective check valve.
 - Pump is working, but not producing desired output. Pump needs to be rebuilt.
 - Main filter plugged. Check filter by tank and clean if necessary.
 - Tip or tip screen plugged. Check both tip and tip screen and clean if necessary.
 - Kink in hose. Straighten or replace hose.
 - Voltage from tractor is low. Check power cord with multimeter for 12 volts at baler mounted processor. Clean connections on battery. Dielectric grease connections at baler mounted processor and at hitch connection.
 - Pump is defective. Rebuild pump if motor runs smoothly. Replace pump if motor is bad.
 - Defective flow meter. Only if all pumps run, product is applied, and all numbers read 0.
- To set date and time, press the SET DATE/TIME key. In the next screen enter the date (month, day, year format) followed by the time. When done press the ENTER key. NOTE: The clock uses military (or 24 hour) time.
- The voltage should be between 12.0 to 14.5 volts for the system to work properly. If voltage is not in this range check all power cord connections and the tractors charging system.
- When done in this mode, press the MAIN MENU key.

COMMON QUESTIONS ABOUT THE 465

1. How do I turn the system on/off?

To turn the system ON simply press anywhere on the right side of the screen followed by pressing the “Press to Start” key. To turn the system OFF, return to the Main Menu screen and press the POWER OFF key.

2. How to get in the LBS/TON, MC%, and TONS/HR menus?

In the Main Menu press the SETUP MODE key. From this screen you can change your application rates and how much product is applied. See SETTING UP FOR INITIAL USE for a detailed explanation of this process.

3. The unit is stuck in the MC% screen.

In the MC% screen, level 1 must be less than level 2, and level 2 must be less than level 3. For example, if level 1 is set at 16, level 2 must be set at 17 or higher, and level 3 must be set higher than level 2.

4. How does OVERRIDE work?

Override turns on all three pumps at full output. The pumps will remain at full output until the operator turns these pumps off by pressing the OVERRIDE key again.

5. The flow meter reading is more or less than the programmed level set in the box.

Some variation in flow meter readings compared to the programmed set point is normal due to factory tolerances on the pump motors as well as varying tractor voltages inputted to the control box. The flow meter reading is an accurate measure of how much product is actually being applied. The set points then will need to be adjusted if you want to attain a different flow meter reading.

6. Why don't all the pumps turn on even at higher application rates?

The selections of what pumps turn on when are automatically controlled by the control box's flow rate look up chart. Thus, not all the pumps turn on at once and the combination of what pumps turn on when is automatically controlled by the software. If you want to make sure all three pumps are working, go to the Diagnostics screen and run pump outputs.

7. The moisture content displays “LO” or “HI” all the time.

When the moisture content display does not change frequently while baling, there is likely a faulty star wheel connection. One of the first places to check is inside the white star wheel block. Check to see if the electronic swivel is in the star wheel shaft and check to see that the star wheel shaft is not working out of the block. Also, check all star wheel wires and connectors to see if there is a continuity or grounding problem.

8. Should the battery connections be removed before jump starting or charging a battery?

Yes. Anytime the tractor will have voltage going up rapidly the connections should be removed.

MAINTENANCE

1. Clean the tip strainers and main strainer every 10 hours of operation or more frequently if required.
2. Depending on the product being used, the system may need to be flushed with water at a regular interval (consult with manufacturer of the chemical.) If Harvest Tec product is being used, flushing is not necessary.
3. Although the pump can run dry, extended operation of a dry pump will increase wear. Watch the preservative level in the tank.
4. Cover the automatic cab terminal on open station tractors if left outside.
5. Pump performance may start to decline after 400 hours (10000 bales on large square balers) of use. Rebuilding the pump is a simple procedure if the motor is not damaged. Order pump rebuilding kit #007-4581 for the automatic unit.
6. If you are using bacterial inoculants, flush your system daily after every use.
7. Clean tank cap every 10 hours of operation.

Maintenance Schedule

	Daily	10 hrs	400 hrs	Weekly	Monthly	Season
Diagnostics	X					X
Filter bowl cleaning		X				X
Tip screen cleaning		X				X
Tank cap cleaning		X				X
Dielectric grease connections					X	X
Rebuild pump			X			
Battery connections				X		X
Check valves			X			
Visually inspect hoses				X		X

WINTER STORAGE

1. Thoroughly flush the system with water.
2. Remove the filter bowl and run dry until the water has cleared out of the intake side.
3. Remove the red plug from the bottom of the pump, drain, and run the pump for 30 seconds or until it is dry.
4. Drain all lines on the outlet side.
5. Never use oils or alcohol based anti-freeze in the system.
6. For spring start-up, if the pump is frozen, turn off the power immediately to avoid burning the motor out. The pump head can be disassembled and freed or rebuilt in most cases.
7. Disconnect power from the baler mounted processor.
8. Remove display from tractor and store in a warm, dry place.

TROUBLE SHOOTING CHECKS:

<u>PROBLEM</u>	<u>POSSIBLE CAUSE</u>	<u>SOLUTION</u>
Pump will not run.	1. No voltage to Baler Mounted Processor.	1. Check for short, low voltage, and replace fuse if necessary.
	2. Pump locked up.	2. Clean or rebuild pump if motor is OK.
	3. Damaged wire.	3. Repair damaged wire.
Pump runs but will not prime.	1. Air leak in intake.	1. Tighten fittings on intake side.
	2. Clogged intake.	2. Clean.
	3. Restricted outlet.	3. Check and clean tips.
	4. Check valve on outlet stuck closed.	4. Clean or repair check valve.
	5. Dirt inside pump.	5. Replace pump check valve.
Pump does not develop enough output.	1. Air leaks or clogs on inlet side.	1. Tighten or clean filter bowl assembly.
	2. Pump worn or dirty.	2. Rebuild pump.
Moisture reading errors (high or low)	1. Wire disconnected or bad connection between star wheels and baler mounted processor.	1. Reconnect wire.
	2. Low power supply to baler mounted processor.	2. Check voltage at box. (Min of 12 volts required.) See Diagnostics section of manual.
	3. Wet hay over 32% moisture	
	4. Ground contact with one or both star wheels and baler mounted processor.	4. Reconnect.
	5. Short in wire between star wheels and baler mounted processor.	5. Replace wire.
	6. Check hay with hand tester to verify.	6. Contact Harvest Tec if conditions persist.
Moisture readings erratic.	1. Test bales with hand tester to verify that cab monitor has more variation than hand tester.	
	2. Check all wiring connections for corrosion or poor contact.	2. Apply dielectric grease to all connections.
	3. Check power supply at tractor. Voltage should be constant between 12 and 14 volts.	3. Install voltage surge protection on tractors alternator.
Flow meter readings do not match up with product usage.		
Product is less than actual product used.	1. Voltage supplied to meter is less than 6 volts.	1. Check for a min of 6 volts supplied at baler mounted processor.
	2. Wiring short in signal to baler mounted processor.	2. Inspect wire and replace if necessary.
	3. Clog in meter.	3. Back flush with water. DO NOT USE AIR.
	4. Using product other than Harvest Tec	4. Catch and weigh product to check outputs.
Product shown is more than actual	1. High voltage supplied to the	1. Check voltage at baler mounted

product used.	meter.	processor. Max of 18 volts.
	2. Light interference with meter.	2. Reflection into meter can cause a high reading. Move meter or protect from sunlight.
	3. Air leak in intake.	3. Look for air bubbles in line. Replace line or other defective area that is allowing air into the system.
	4. Using product other than Harvest Tec	4. Catch and weigh product to check outputs.
System leaks product out of tips after shut down.	1. Dirty or defective check valves.	1. Clean or Replace.
Terminal reads under or over power.	1. Verify with mult-meter actual voltage. Voltage range should be between 12-14 volts.	1. Clean connections and make sure applicator is hooked to battery. See Diagnostics section of manual.
System always displays "End of Row Pause".	1. Flow meter connector plug is plugged into Hay Indicator port on Baler Mounted Processor.	1. Switch ports.
System does not pause at the end of a row.	1. Short in cable.	1. Replace cable.
Bale rate displays zero.	1. Bale rate sensors are reversed. 2. Short in cable.	1. Switch the sensors next to the star wheel. 2. Replace cable.
Display will not power up.	1. Display connector plug and bale rate sensors plug are switched on the Baler Mounted Processor. 2. Short in display cable.	1. Switch plugs. 2. Replace cable.
Display is too dark or light	1. Change in temperature or light conditions.	1. Use the monitors contrast control.
	2. Display and BMP not communicating.	2. Disconnect 12 volt power cable at hitch. DO NOT DISCONNECT DISPLAY CABLE. Wait 5 minutes and reconnect.
Display says waiting for BMP	1. Display and BMP not communicating.	1. Disconnect 12 volt power cable at hitch. DO NOT DISCONNECT DISPLAY CABLE. Wait 5 minutes and reconnect.

BACKUP FUSE

The Model 465 is equipped with a backup system if your display is not functioning. This function is intended for use only as a temporary means for application and not as a way to apply preservative over multiple fields or for a lengthy amount of time. The baler mounted processor has a location for a backup fuse on the same side as the pump and flow meter harnesses that bypasses all other system inputs and applies preservative using one pump (Pump Three) at a constant lbs/hour shown below. These values are based upon an input voltage of 13.5 DC. Insert at least a 10 amp up to 20 amp fuse (3 AG style) into the backup fuse port to activate the bypass. The system will not turn off or pause until the fuse is removed. The main fuse must also be functional for the backup fuse to work.

	Tip Set	Output (lbs/hour)
465	High	230
	Low	150

WIRING DIAGRAMS

A. Main power connector mounted on battery

Pin 1	Red	+ 12 V input from tractor supply
Pin 2	Black	Ground from tractor supply
Pin 3	Not used	



B. Main power connector mounted on BMP

Pin 1	Red	+ 12 V input from tractor supply
Pin 2	Black	Ground from tractor supply
Pin 3	Not used	

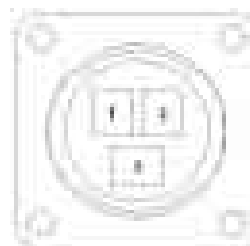

C. Pump connection colors

Pin 1	Black with orange markings	Pump 1 ground
Pin 2	Black with green markings	Pump 2 ground
Pin 3	Black with yellow markings	Pump 3 ground
Pin 4	Not used	
Pin 5	Orange with black markings	Pump 1 positive
Pin 6	Green with black markings	Pump 2 positive
Pin 7	Yellow with black markings	Pump 3 positive



D. Flow meter connection on BMP

Pin 1	White	5 - 12 V (+) supply
Pin 2	Green	Ground
Pin 3	Brown	Signal
Pin 4	Black	Shield



E. Connector for Hay Indicator option on BMP

Note: Hay indicators are an option that will turn the system on and off automatically as hay enters the pickup of the baler.

Pin 1	Red	+12V
Pin 2	Black	Ground
Pin 3	White	Signal wire
Pin 4	Not used	

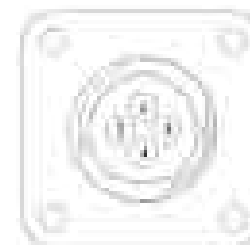

F. Bale rate sensors on BMP

Pin1	Brown	Sensor power
Pin2	Black	Signal for front prox. sensor
Pin3	Blue	Sensor ground
Pin4	Black	Signal for back prox. sensor



G. Star wheel connector mounted on BMP

Pin 1	Brown	Star wheel input 1
Pin 2	Blue	Star wheel input 2
Pin 3	Brown	Diagnostic 1
Pin 4	Blue	Diagnostic 2
Pin 5	Silver	Shield
Pin 6	Silver	Shield
Pin 7	Not used	
Pin 8	Not used	
Pin 9	Not used	



H. Communication harness display to hitch

Pin 1	Red	Power to display
Pin 2	Black	Ground to display
Pin 3	Blue	Comm channel OH
Pin 4	Orange	Comm channel OL

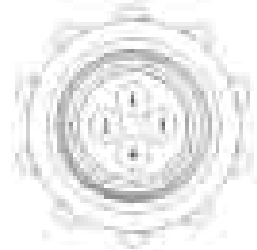

I. Communication harness hitch to baler mounted processor

Pin 1	Red	Power to display
Pin 2	Black	Ground to display
Pin 3	Blue	Comm channel OH
Pin 4	Orange	Comm channel OL



TANK, SADDLE, AND LEGS PART #'S

Vermeer, Claas, and Krone balers with 100 gallon tank

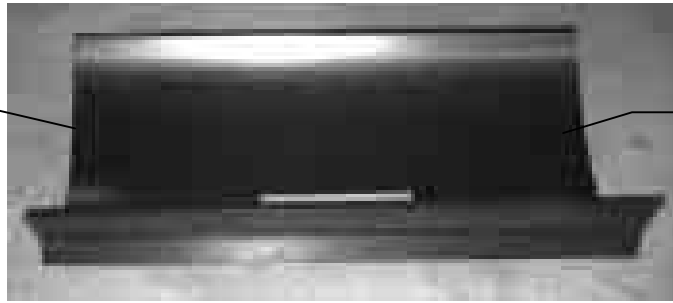

Tank Saddle
Part#:001-6706A

Tank lid
005-9022C

Tank for:
Vermeer, Claas,
and Krone balers

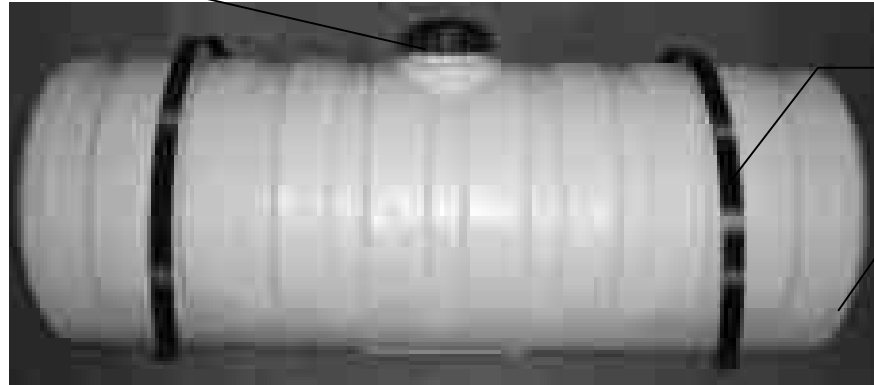

Tank straps
001-4402

100-gl tank
005-9206

Legs for Vermeer, Claas
and Krone Balers

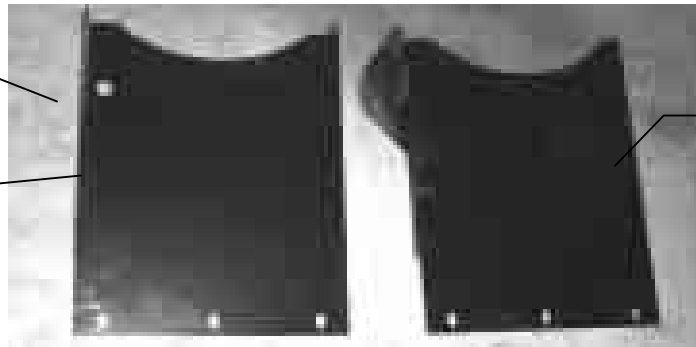

Left Leg
Part #:001-6706V

Right Leg
Part #:001-6706V

Legs for Agco,
Hesston,
Massey &
Challenger

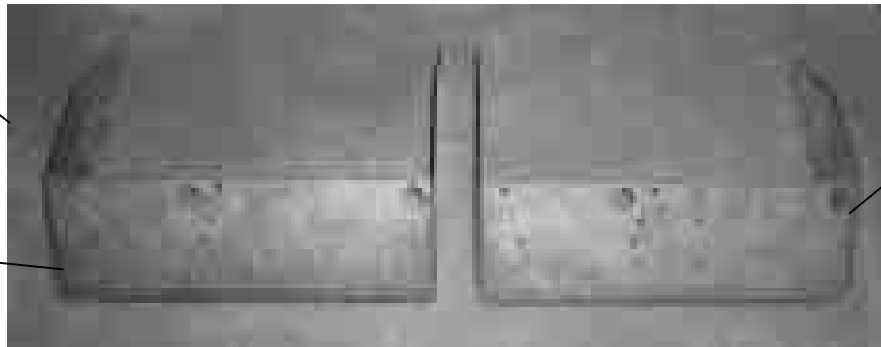

Saddle leg
Part# 001-6707C

Saddle leg
Part# 001-6707C

Legs for New
Holland BB940A,
BB960A and
Case IH LBX 332,
LBX 432 series
balers with 110
gallon tanks

Not Pictured:
Vicon Leg spacers
001-6707BS
QTY 2

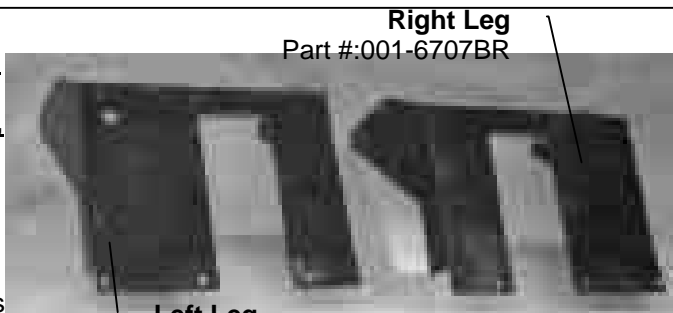

Left Leg
Part#:001-6707BL

Tank Saddle
Part#:001-6707A

Right Leg
Part #:001-6707BR

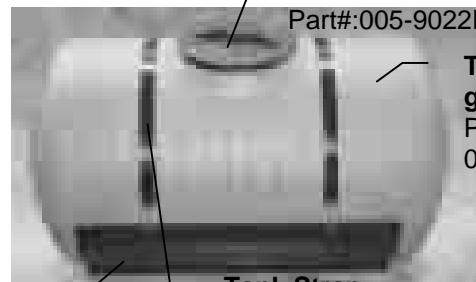

Tank Lid
Part#:005-9022E

**Tank-110
gallon**
Part#:
005-9208

Tank Strap
Part#:001-4402B

PARTS BREAKDOWN FOR PUMP PLATE

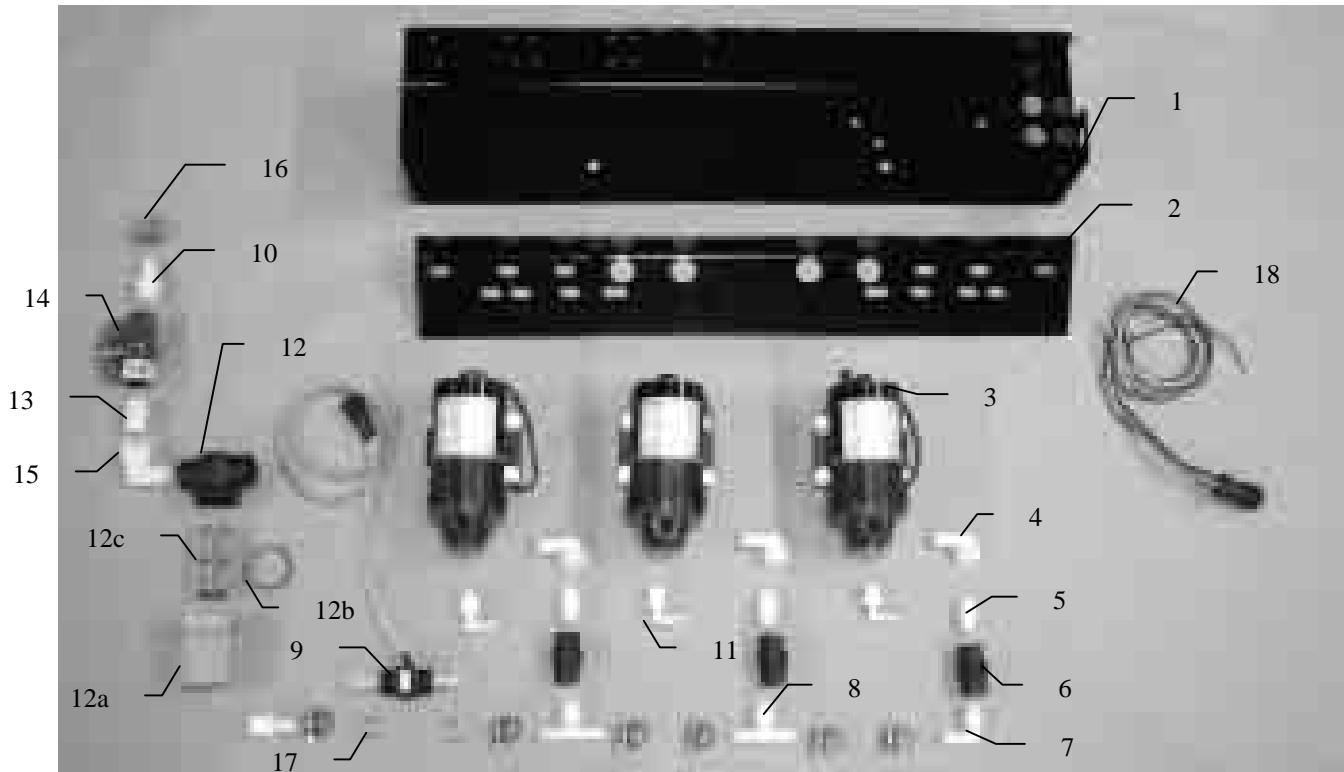

<u>Ref#</u>	<u>Description</u>	<u>Part#</u>	<u>Qty</u>
1	Pump plate	001-4646D	1
2	Mounting Bracket	001-4646C	1
3	Pump	007-4120H	3
4	Street elbow fitting	003-SE38	3
5	Nipple fitting	003-M3838	3
6	Check valve	002-4566F	3
7	Elbow fitting	003-EL3812	1
8	Tee fitting	003-T3812HB	2
9	Flow meter assembly	006-4725A	1
10	Straight fitting	003-A1212	2
11	Elbow fitting	003-EL3814	3
12	Filter bowl assembly	002-4315	1
12a	Filter bowl only	002-4315F	1
12b	Filter bowl gasket	002-4315D	1
12c	Filter bowl screen	002-4315B	1
13	Nipple fitting	003-M1212	1
14	Ball valve	002-2212	1
15	Street elbow fitting	003-SE12	1
16	Hose clamp	003-9003	7
17	Hose clamp (Flow Meter)	003-9005	2
18	Pump Cable	006-4660Z	1
NP	Pump rebuild kit (1 per pump)	007-4581	1
NP	Not Pictured		

PARTS BREAKDOWN FOR STAR WHEEL SENSOR

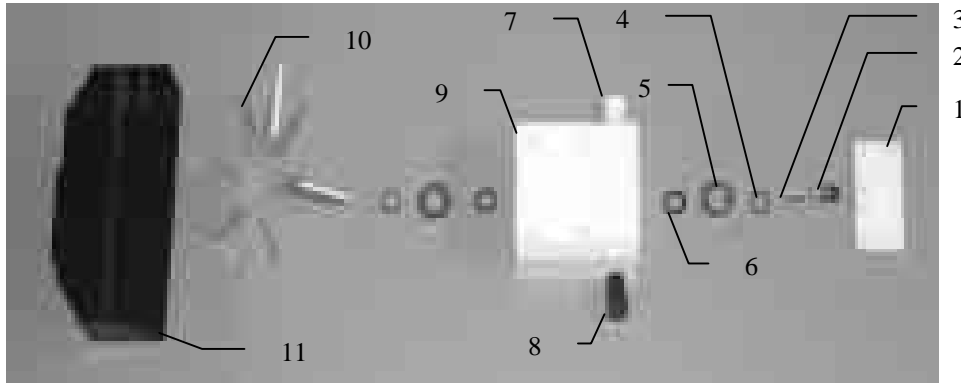

<u>Ref</u>	<u>Description</u>	<u>Part#</u>	<u>Qty</u>	<u>Ref</u>	<u>Description</u>	<u>Part#</u>	<u>Qty</u>
1.	Block cover	006-4641B	2	7.	Plug fitting	003-F38	2
2.	Electronic swivel	006-4642A	2	8.	Wiring grommet	008-0821A	2
3.	Swivel insert	006-4642B	2	9.	Star wheel block	006-4641A	2
4.	Snap ring		4	10.	Star wheel sensor	006-4641C	2
5.	Washer		4	11.	Twine guard-left	001-4645	1
6.	Dust seal		4		Twine guard-right (prox)	001-4644	1
				1-10	Star wheel assembly	030-4641	2

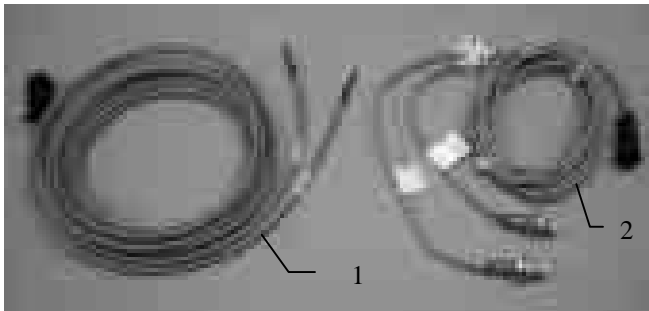

<u>Ref</u>	<u>Description</u>	<u>Part#</u>	<u>Qty</u>
1	Moisture cable	006-4640E	1
2	Bale rate sensors	006-7202	1

VICON BALERS

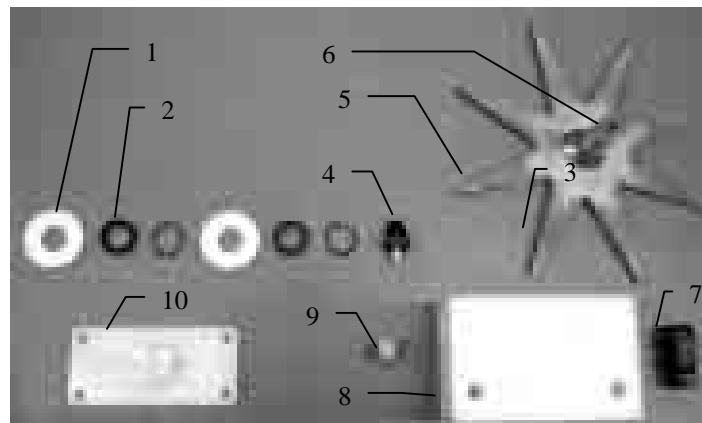

<u>Ref</u>	<u>Description</u>	<u>Part#</u>	<u>Qty</u>	<u>Ref</u>	<u>Description</u>	<u>Part#</u>	<u>Qty</u>
1	Washer		4	6	Insert	006-4642B	2
2	Dust Seal		4	7	Wiring grommet	008-0821A	2
3	Snap Ring		4	8	Star wheel block	006-4641A	2
4	Swivel	006-4642A	2	9	Plug Fitting	003-F38	2
5	Star Wheel	006-4641C	2	10	Block Cover	006-4641B	2
				1-10	Star wheel assembly	030-4642	2

PARTS BREAKDOWN FOR CONTROL BOX AND WIRING HARNESSSES AND HOSES

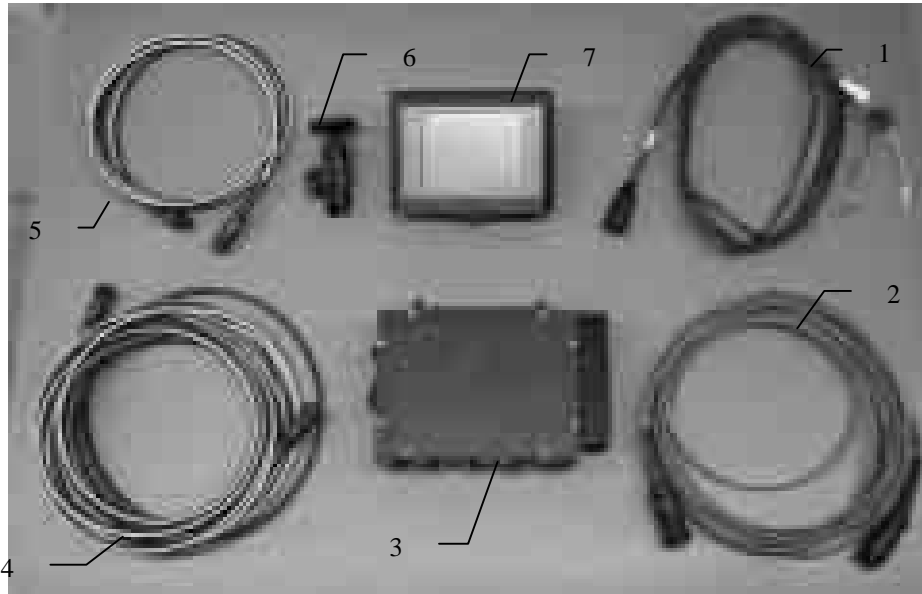

<u>Ref</u>	<u>Description</u>	<u>Part#</u>
1	Power lead tractor	006-4640A
2	Power lead baler	006-4660K
3	Baler mounted processor	006-4671LS
4	Communication harness (baler)	006-4660L
5	Communication harness (tractor)	006-4660N
6	Ram mount	001-2012H
7	465 Terminal	006-4670

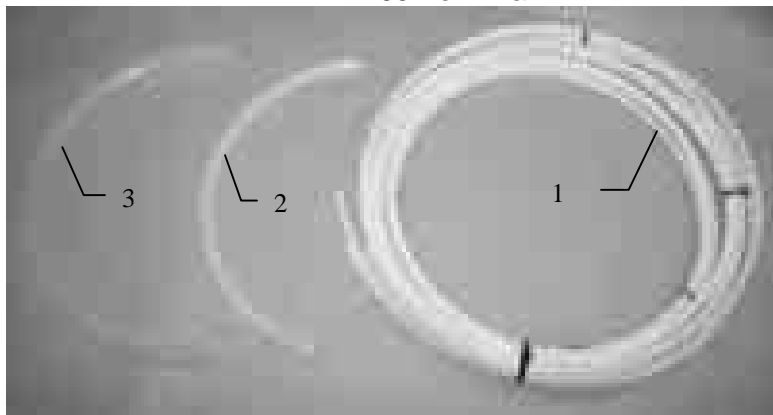

<u>Ref</u>	<u>Description</u>	<u>Part#</u>	<u>Qty</u>	<u>Ref</u>	<u>Description</u>	<u>Part#</u>	<u>Qty</u>
1	Triple weld hose (from pumps to tips)	002-9016	35ft	7	Female Coupler	002-2204A	1
		002-9016B	35ft				
		002-9016G	35ft				
	Three hose assembly	030-9016LS	1				
2	1/2" Hose (tank to filter)	002-9001	6ft	8	Male Coupler	002-2205G	1
3	3/4" Hose (tank to drain/fill valve)	002-9002	5ft	9	Valve Holder	001-6702H	1
4	Straight Fitting	003-A3434	1	10	Ball valve	002-2200	1
5	Elbow	003-EL3434	1	11	Jiffy Clip	008-9010	3
6	Hose Clamps	003-9004	2				

4438B INSTALLATION KIT

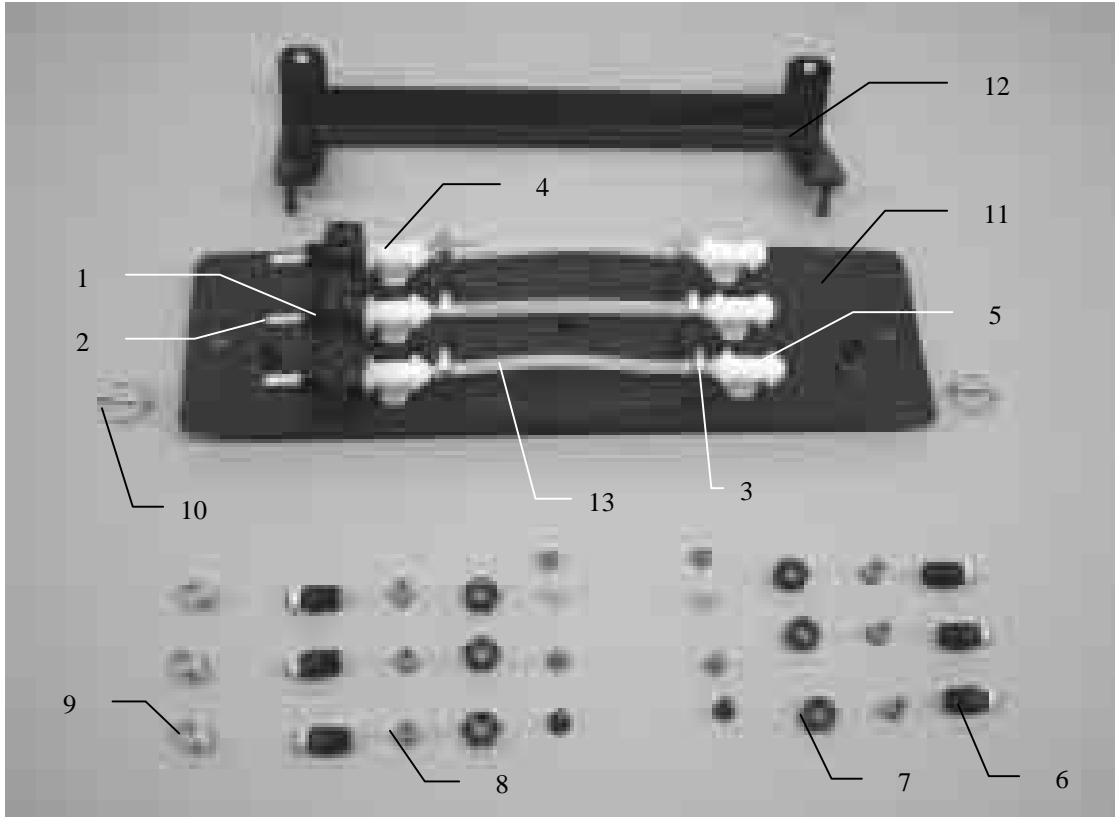

<u>Ref</u>	<u>Description</u>	<u>Part #</u>	<u>Qty</u>	<u>Description</u>	<u>Part #</u>	<u>Qty</u>
1	Check valve	004-1207VB	3	Tip	004-800067-PT	2
2	Straight fitting	003-A1414VB	3	Tip	004-TT11001VP	2
3	Straight fitting	003-A1414	6	Tip	004-TT110015VP	2
4	Tee	003-TT14SQ	3	Tip	004-TT11003VP	2
5	Street elbow	003-SE14F	3			
6	Nozzle body	004-4722	6			
7	Nozzle cap	004-4723	9			
8	Tip strainer	004-1203-100	6			
9	Hose clamp	003-9002	9			
10	Lynch pin	008-4576	2			
11	Spray shield	001-4438A	1			
12	Mounting bracket	001-4438B	1			
13	Hose – 1/4"	002-9016	3ft			

4439B INSTALLATION KIT

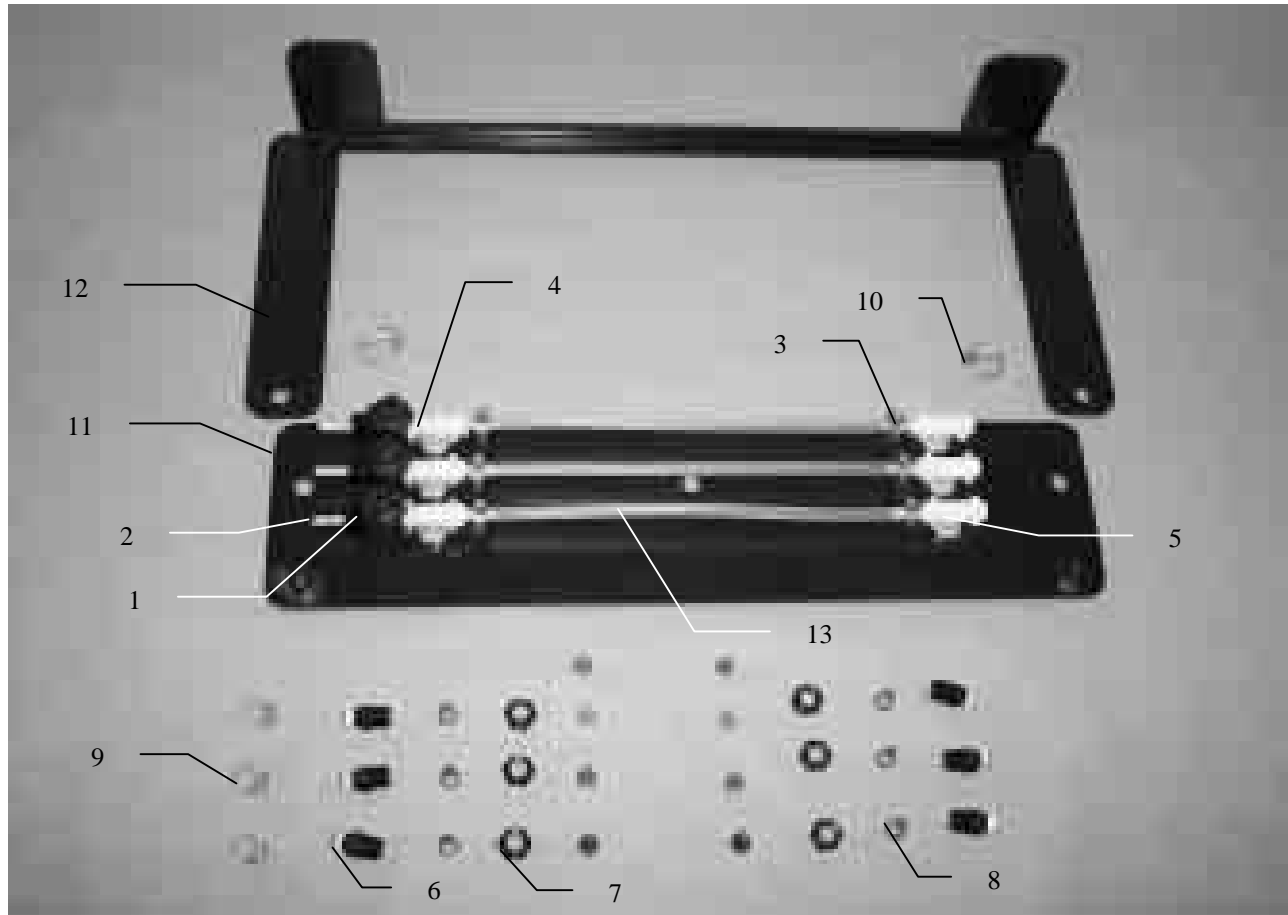

<u>Ref</u>	<u>Description</u>	<u>Part #</u>	<u>Qty</u>	<u>Description</u>	<u>Part #</u>	<u>Qty</u>
1	Check valve	004-1207VB	3	Tip	004-800067-PT	2
2	Straight fitting	003-A1414VB	3	Tip	004-TT11001VP	2
3	Straight fitting	003-A1414	6	Tip	004-TT110015VP	2
4	Tee	003-TT14SQ	3	Tip	004-TT11003VP	2
5	Street elbow	003-SE14F	3			
6	Nozzle body	004-4722	6			
7	Nozzle cap	004-4723	9			
8	Tip strainer	004-1203-100	6			
9	Hose clamp	003-9002	9			
10	Lynch pin	008-4576	2			
11	Spray shield	001-4439A	1			
12	Mounting bracket	001-4439B	1			
13	Hose – 1/4"	002-9016	3			

4490B INSTALLATION KIT

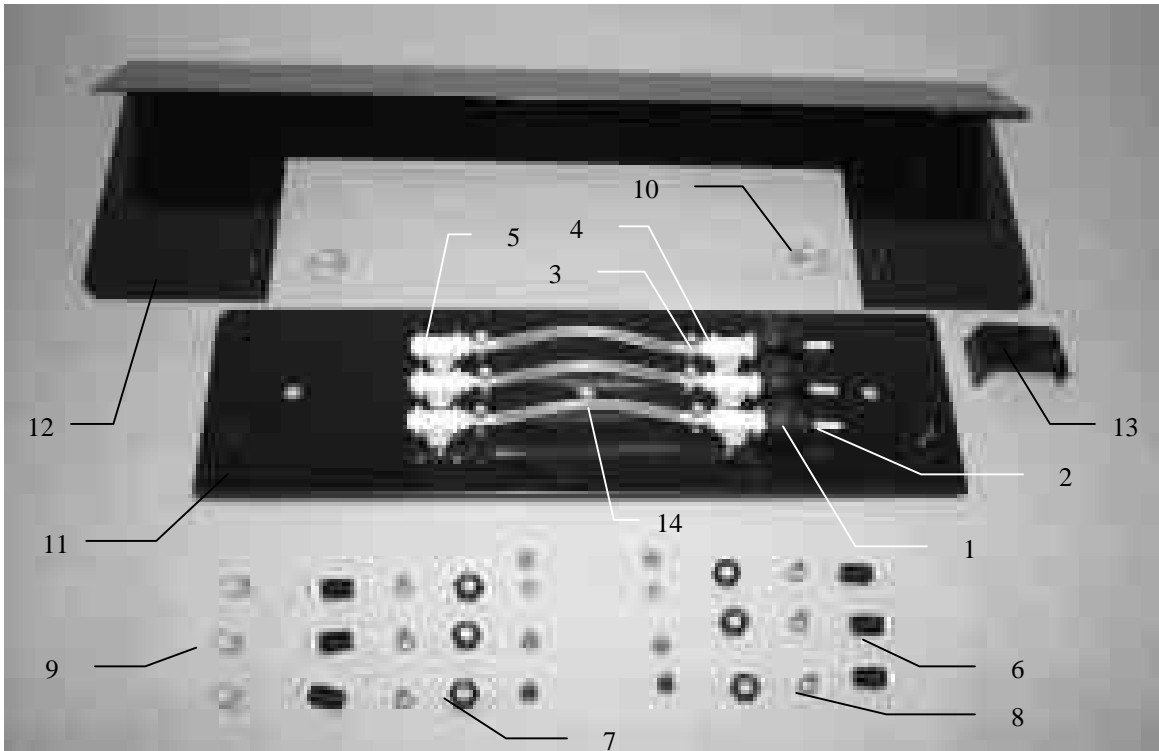

<u>Ref</u>	<u>Description</u>	<u>Part #</u>	<u>Qty</u>	<u>Description</u>	<u>Part #</u>	<u>Qty</u>
1	Check valve	004-1207VB	3	Tip	004-800067-PT	2
2	Straight fitting	003-A1414VB	3	Tip	004-TT11001VP	2
3	Straight fitting	003-A1414	6	Tip	004-TT110015VP	2
4	Tee	003-TT14SQ	3	Tip	004-TT11003VP	2
5	Street elbow	003-SE14F	3			
6	Nozzle body	004-4722	6			
7	Nozzle cap	004-4723	9			
8	Tip strainer	004-1203-100	6			
9	Hose clamp	003-9002	9			
10	Lynch pin	008-4576	2			
11	Spray shield	001-4421	1			
12	Shield holder	001-4421B	1			
13	Backing plate	001-4421A	1			
14	Hose – 1/4"	002-9016	3ft			

MODEL 4491B INSTALLATION KIT

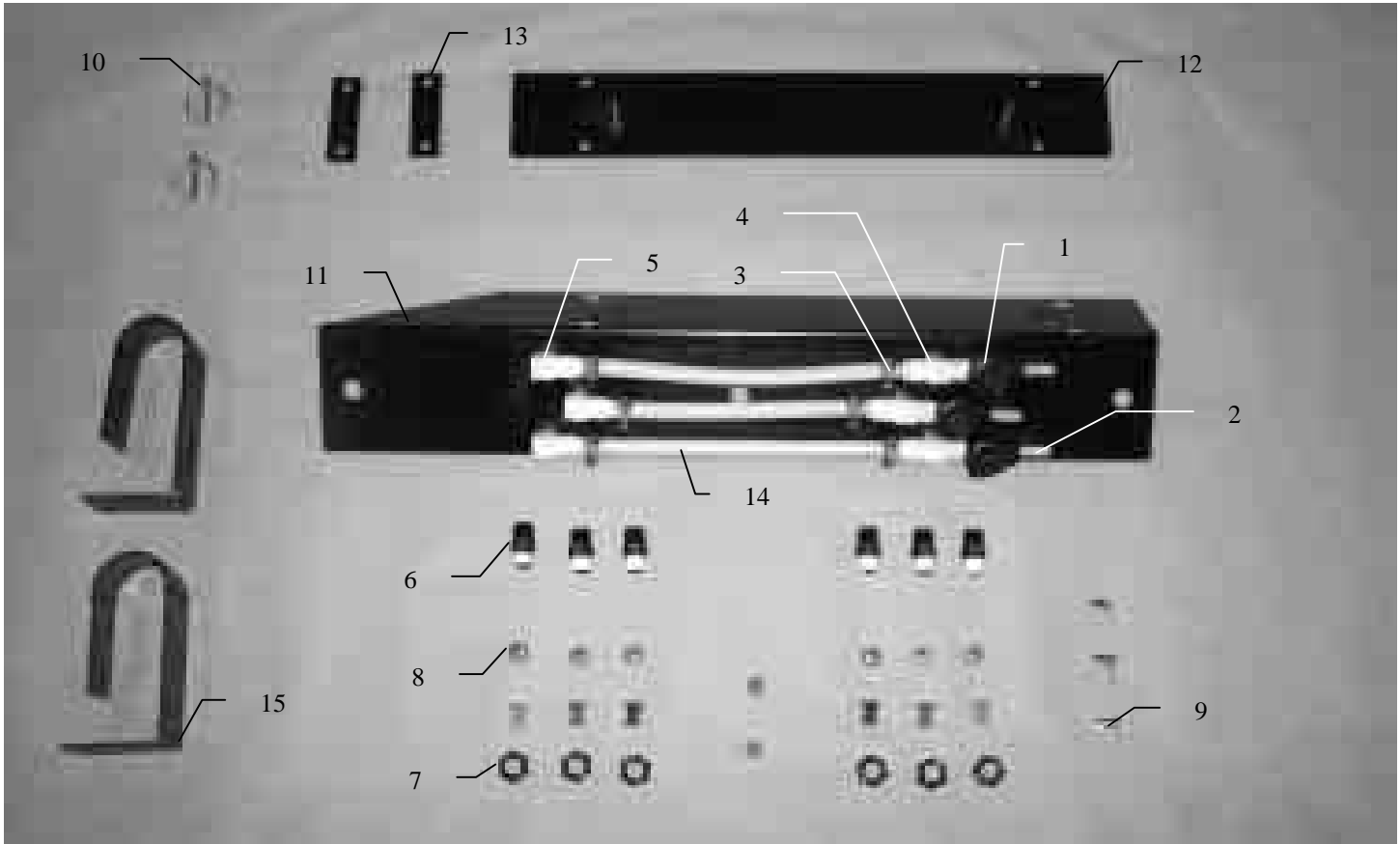

<u>Ref</u>	<u>Description</u>	<u>Part #</u>	<u>Qty</u>	<u>Description</u>	<u>Part #</u>	<u>Qty</u>
1	Check valve	004-1207VB	3	Tip	004-800067-PT	2
2	Straight fitting	003-A1414VB	3	Tip	004-TT11001VP	2
3	Straight fitting	003-A1414	6	Tip	004-TT110015VP	2
4	Tee	003-TT14SQ	3	Tip	004-TT11003VP	2
5	Street elbow	003-SE14F	3			
6	Nozzle body	004-4722	6			
7	Nozzle cap	004-4723	9			
8	Tip strainer	004-1203-100	6			
9	Hose clamp	003-9002	9			
10	Lynch pin	008-4576	2			
11	Spray shield	001-4422	1			
12	Shield holder	001-4422B	1			
13	Backing plate	001-4422A	2			
14	Hose – 1/4"	002-9016	3ft			
15	Ladder bracket	001-6707H	2			

MODEL 4492B INSTALLATION KIT

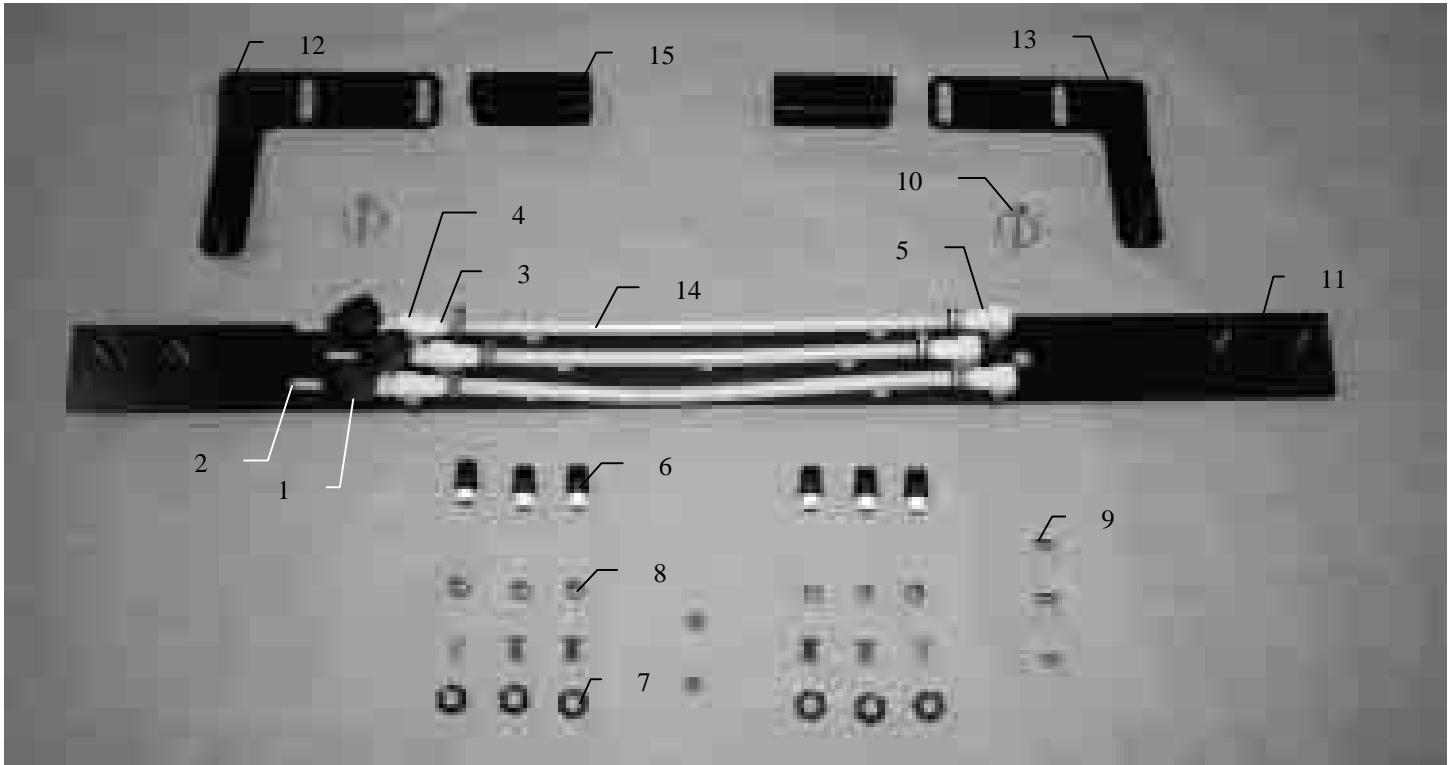

<u>Ref</u>	<u>Description</u>	<u>Part #</u>	<u>Qty</u>	<u>Description</u>	<u>Part #</u>	<u>Qty</u>
1	Check valve	004-1207VB	3	Tip	004-800067-PT	2
2	Straight fitting	003-A1414VB	3	Tip	004-TT11001VP	2
3	Straight fitting	003-A1414	6	Tip	004-TT110015VP	2
4	Tee	003-TT14SQ	3	Tip	004-TT11003VP	2
5	Street elbow	003-SE14F	3			
6	Nozzle body	004-4722	6			
7	Nozzle cap	004-4723	9			
8	Tip strainer	004-1203-100	6			
9	Hose clamp	003-9002	9			
10	Lynch pin	008-4576	2			
11	Spray shield	001-4811A	1			
12	Left shield holder	001-4436DL	1			
13	Right shield holder	001-4436DR	1			
14	Hose – 1/4"	002-9016	3ft			
15	Spacer	001-4436S	2			

MODEL 4494B INSTALLATION KIT

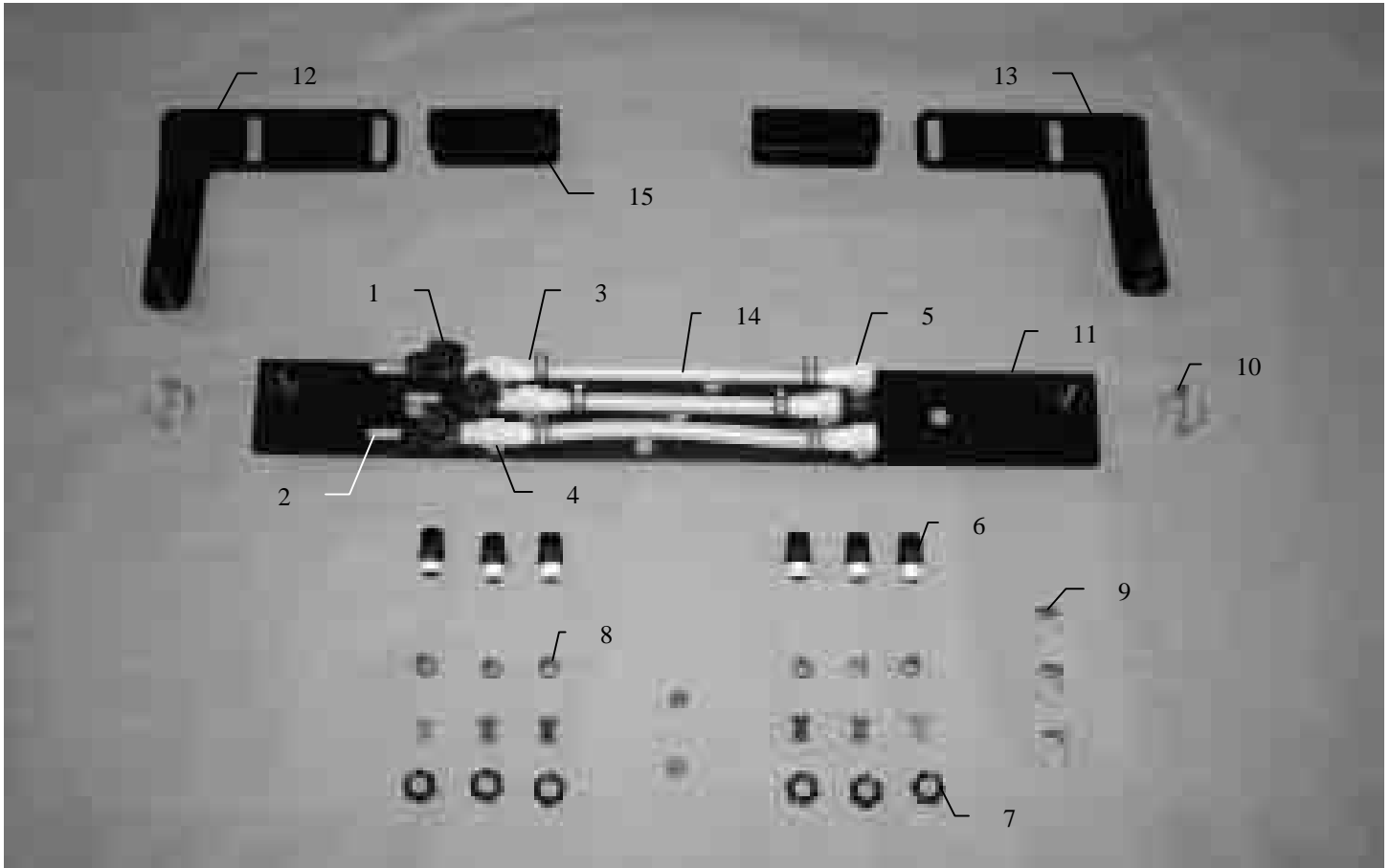

<u>Ref</u>	<u>Description</u>	<u>Part #</u>	<u>Qty</u>	<u>Description</u>	<u>Part #</u>	<u>Qty</u>
1	Check valve	004-1207VB	3	Tip	004-800067-PT	2
2	Straight fitting	003-A1414VB	3	Tip	004-TT11001VP	2
3	Straight fitting	003-A1414	6	Tip	004-TT110015VP	2
4	Tee	003-TT14SQ	3	Tip	004-TT11003VP	2
5	Street elbow	003-SE14F	3			
6	Nozzle body	004-4722	6			
7	Nozzle cap	004-4723	9			
8	Tip strainer	004-1203-100	6			
9	Hose clamp	003-9002	9			
10	Lynch pin	008-4576	2			
11	Spray shield	001-4810	1			
12	Left shield holder	001-4436DL	1			
13	Right shield holder	001-4436DR	1			
14	Hose – 1/4"	002-9016	3ft			
15	Spacer	001-4436S	2			

4495B INSTALLATION KIT

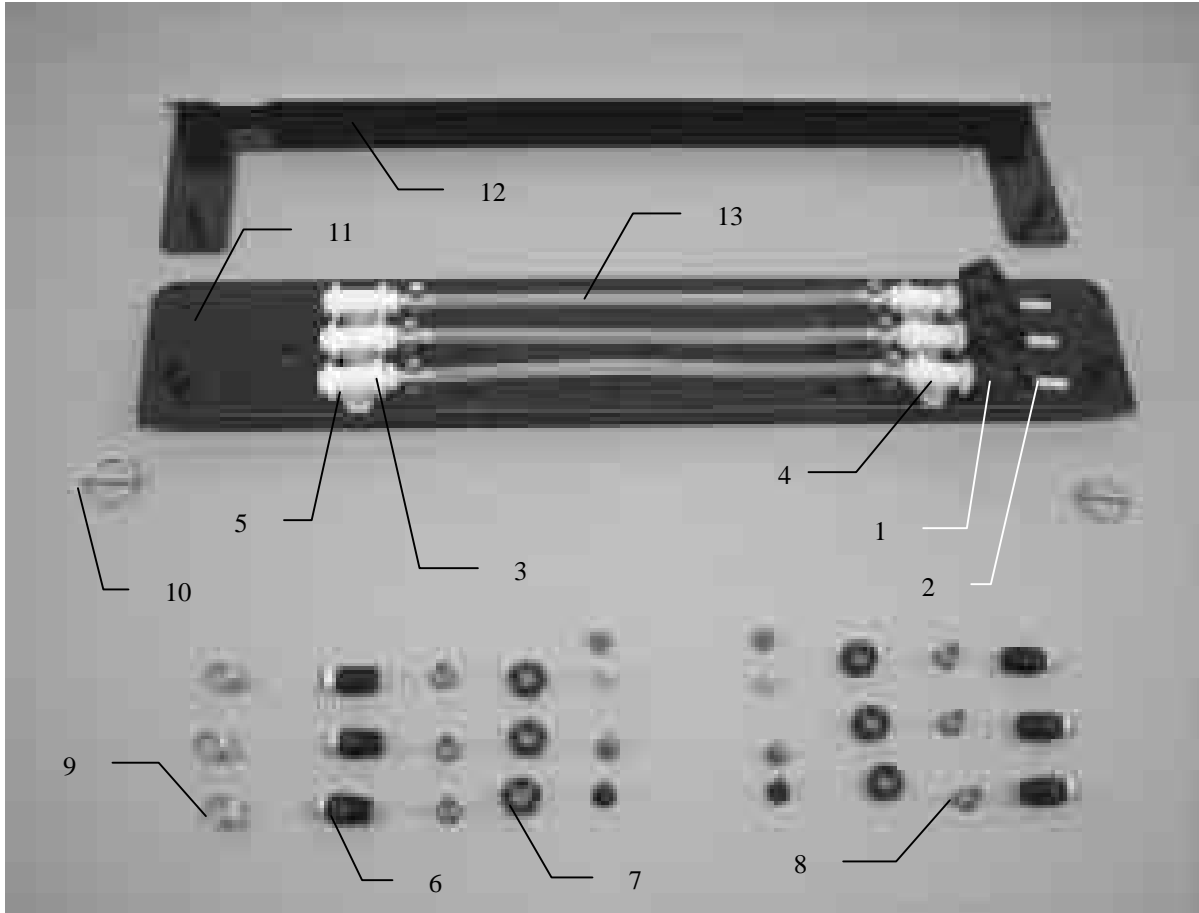

<u>Ref</u>	<u>Description</u>	<u>Part#</u>	<u>Qty</u>	<u>Description</u>	<u>Part#</u>	<u>Qty</u>
1	Check valve	004-1207VB	3	Tip	004-800067-PT	2
2	Straight fitting	003-A1414VB	3	Tip	004-TT11001VP	2
3	Straight fitting	003-A1414	6	Tip	004-TT110015VP	2
4	Tee	003-TT14SQ	3	Tip	004-TT11003VP	2
5	Street elbow	003-SE14F	3			
6	Nozzle body	004-4722	6			
7	Nozzle cap	004-4723	9			
8	Tip strainer	004-1203-100	6			
9	Hose clamp	003-9002	9			
10	Lynch pin	008-4576	2			
11	Spray shield	001-4431	1			
12	Shield holder	001-4431B	1			
13	Hose – 1/4"	002-9016	3ft			

4497B INSTALLATION KIT

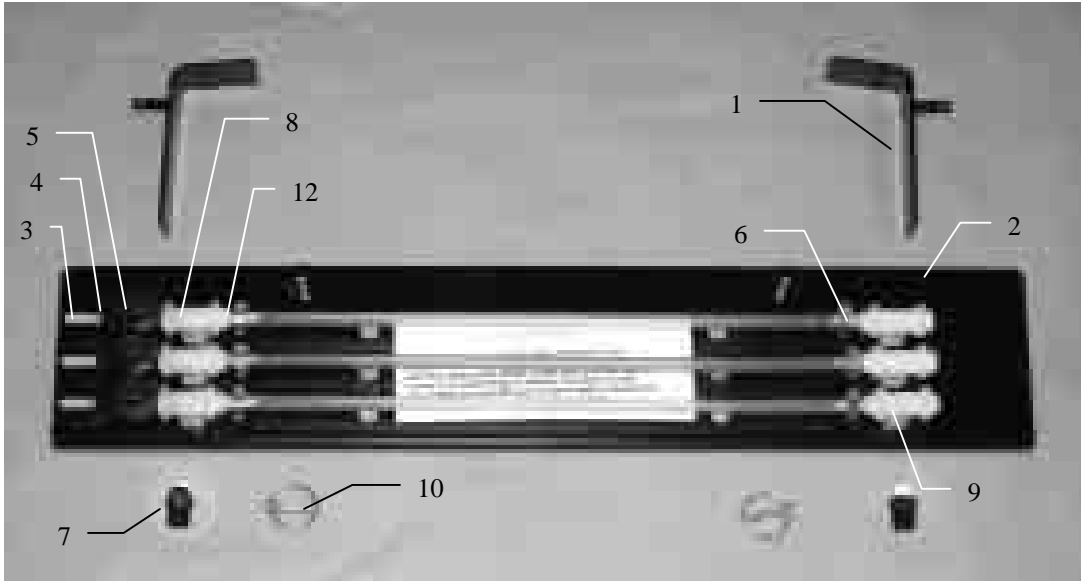

<u>Ref</u>	<u>Description</u>	<u>Part#</u>	<u>Qty</u>	<u>Description</u>	<u>Part#</u>	<u>Qty</u>
1	Mounting Brkt	001-4435E	2	Tip	004-TT11001VP	2
2	Spray Shield	001-4435ES	1	Tip	004-TT110015VP	2
3	Straight Fitting	003-A1414VB	3	Tip	004-TT11003VP	2
4	Nozzle Cap	004-4723	9	Tip	004-800067-PT	2
5	Check Valve	004-1207VB	3	Tip Strainers	004-1203-100	6
6	Straight Fitting	003-A1414	6			
7	Nozzle Body	004-4722	6			
8	Tee	003-TT14SQ	3			
9	Street elbow	003-SE14F	3			
10	Lynch Pin	008-4576	2			
11	Hose	002-9016	4ft			
12	Hose Clamps	003-9002	9			

4499B INSTALLATION KIT

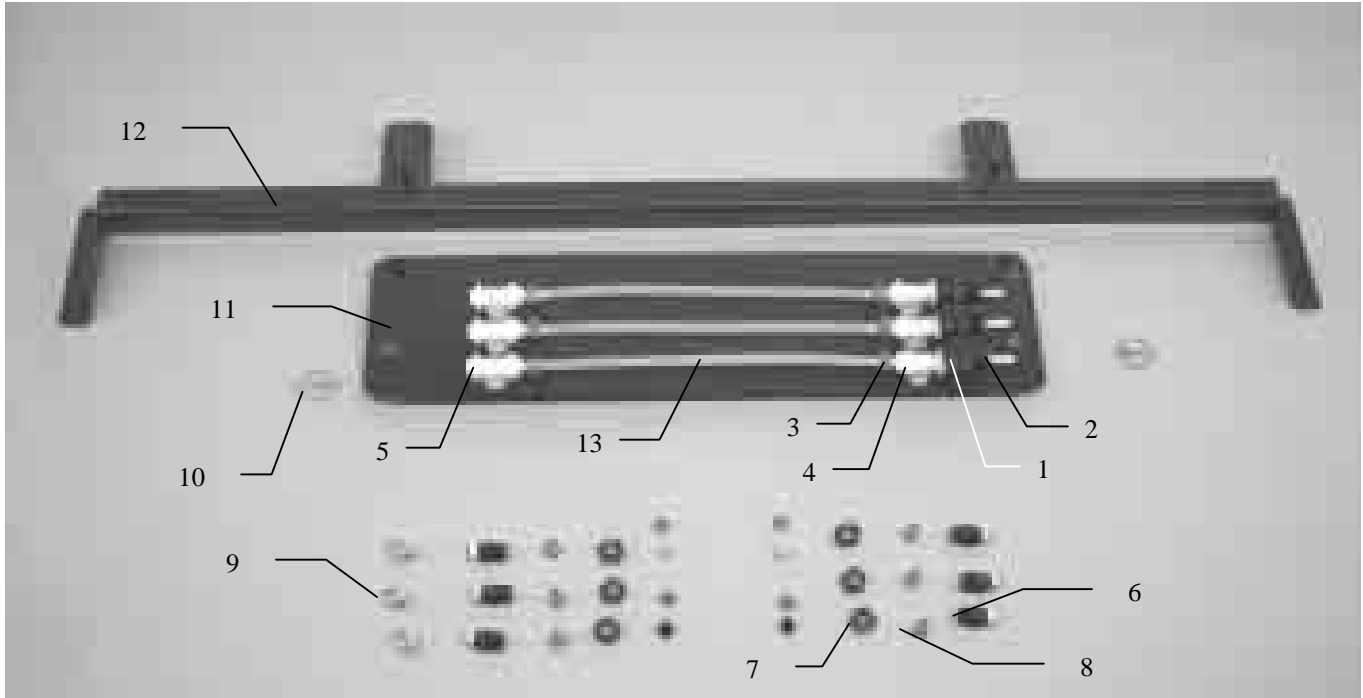

<u>Ref</u>	<u>Description</u>	<u>Part#</u>	<u>Qty</u>	<u>Description</u>	<u>Part#</u>	<u>Qty</u>
1	Check valve	004-1207VB	3	Tip	004-800067-PT	2
2	Straight fitting	003-A1414VB	3	Tip	004-TT11001VP	2
3	Straight fitting	003-A1414	6	Tip	004-TT110015VP	2
4	Tee	003-TT14SQ	3	Tip	004-TT11003VP	2
5	Street elbow	003-SE14F	3			
6	Nozzle body	004-4722	6			
7	Nozzle cap	004-4723	9			
8	Tip strainer	004-1203-100	6			
9	Hose clamp	003-9002	9			
10	Lynch pin	008-4576	2			
11	Spray shield	001-4439A	1			
12	Shield holder	001-4440	1			
13	Hose – 1/4"	002-9016	3ft			

4500B INSTALLATION KIT

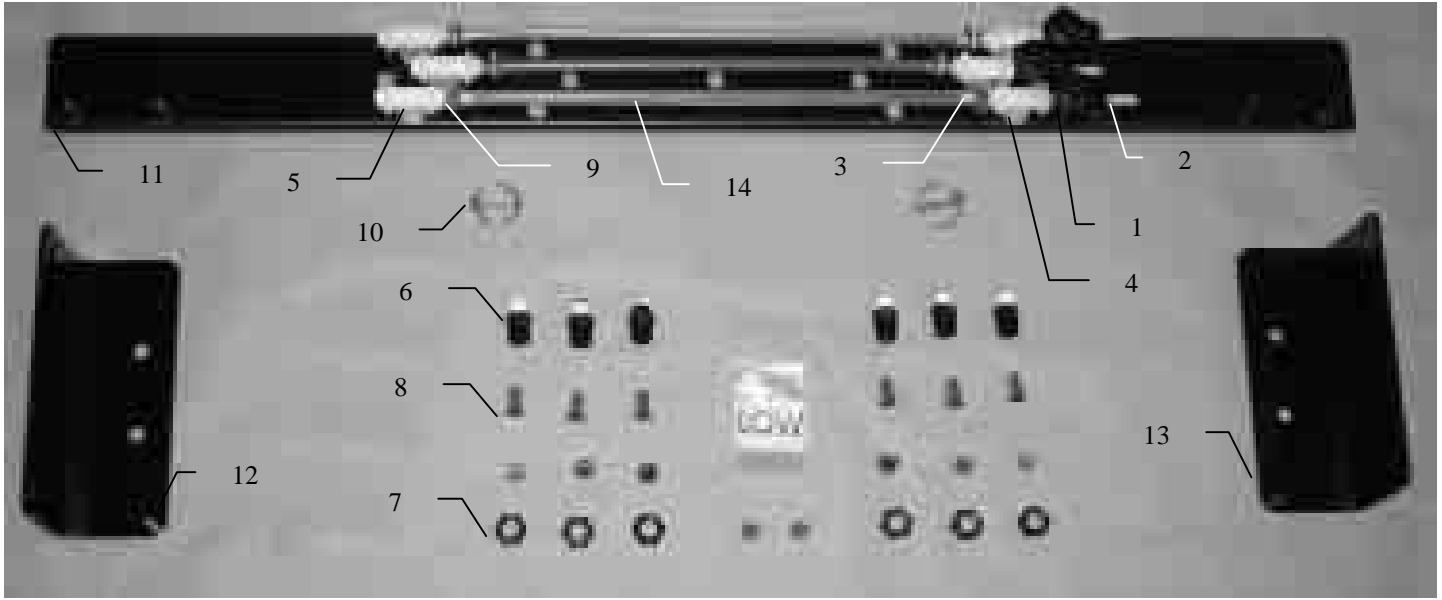

<u>Ref</u>	<u>Description</u>	<u>Part#</u>	<u>Qty</u>	<u>Description</u>	<u>Part#</u>	<u>Qty</u>
1	Check valve	004-1207VB	3	Tip	004-800067-PT	2
2	Straight fitting	003-A1414VB	3	Tip	004-TT11001VP	2
3	Straight fitting	003-A1414	6	Tip	004-TT110015VP	2
4	Tee	003-TT14SQ	3	Tip	004-TT11003VP	2
5	Street elbow	003-SE14F	3			
6	Nozzle body	004-4722	6			
7	Nozzle cap	004-4723	9			
8	Tip strainer	004-1203-100	6			
9	Hose clamp	003-9002	9			
10	Lynch pin	008-4576	2			
11	Spray shield	001-4811A	1			
12	Left shield holder	001-4436CL	1			
13	Right shield holder	001-4436CR	1			
14	Hose	002-9016	3ft			

4501B INSTALLATION KIT

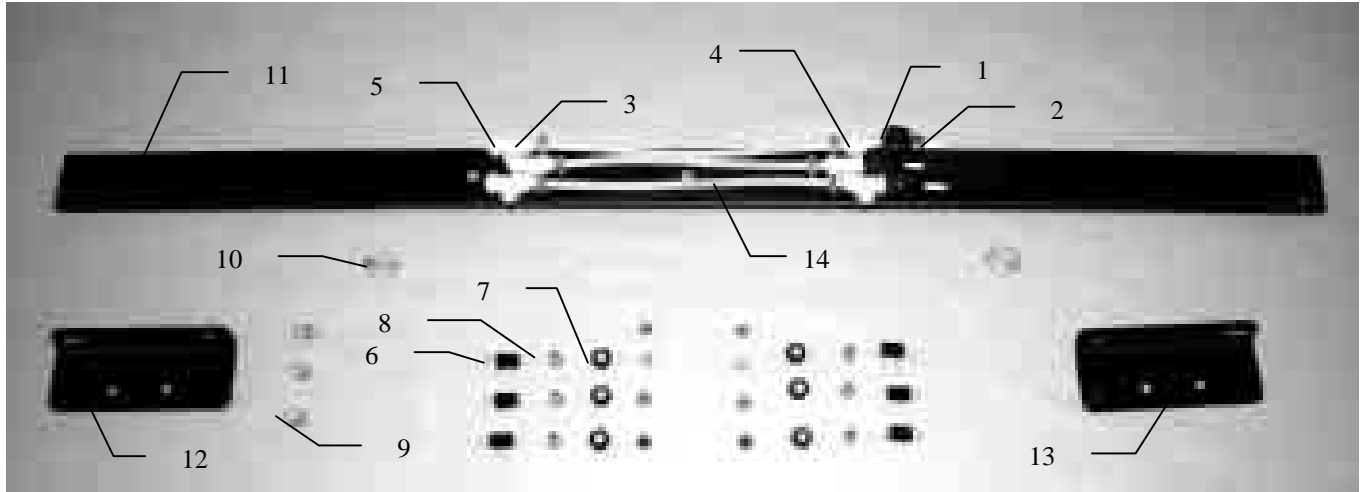

<u>Ref</u>	<u>Description</u>	<u>Part#</u>	<u>Qty</u>	<u>Description</u>	<u>Part#</u>	<u>Qty</u>
1	Check valve	004-1207VB	3	Tip	004-800067-PT	2
2	Straight fitting	003-A1414VB	3	Tip	004-TT11001VP	2
3	Straight fitting	003-A1414	6	Tip	004-TT110015VP	2
4	Tee	003-TT14SQ	3	Tip	004-TT11003VP	2
5	Street elbow	003-SE14F	3			
6	Nozzle body	004-4722	6			
7	Nozzle cap	004-4723	9			
8	Tip strainer	004-1203-100	6			
9	Hose clamp	003-9002	9			
10	Lynch pin	008-4576	2			
11	Spray shield	001-4436CS	1			
12	Left shield holder	001-4436CL	1			
13	Right shield holder	001-4436CR	1			
14	Hose – 1/4"	002-9016	3ft			

4509B INSTALLATION KIT

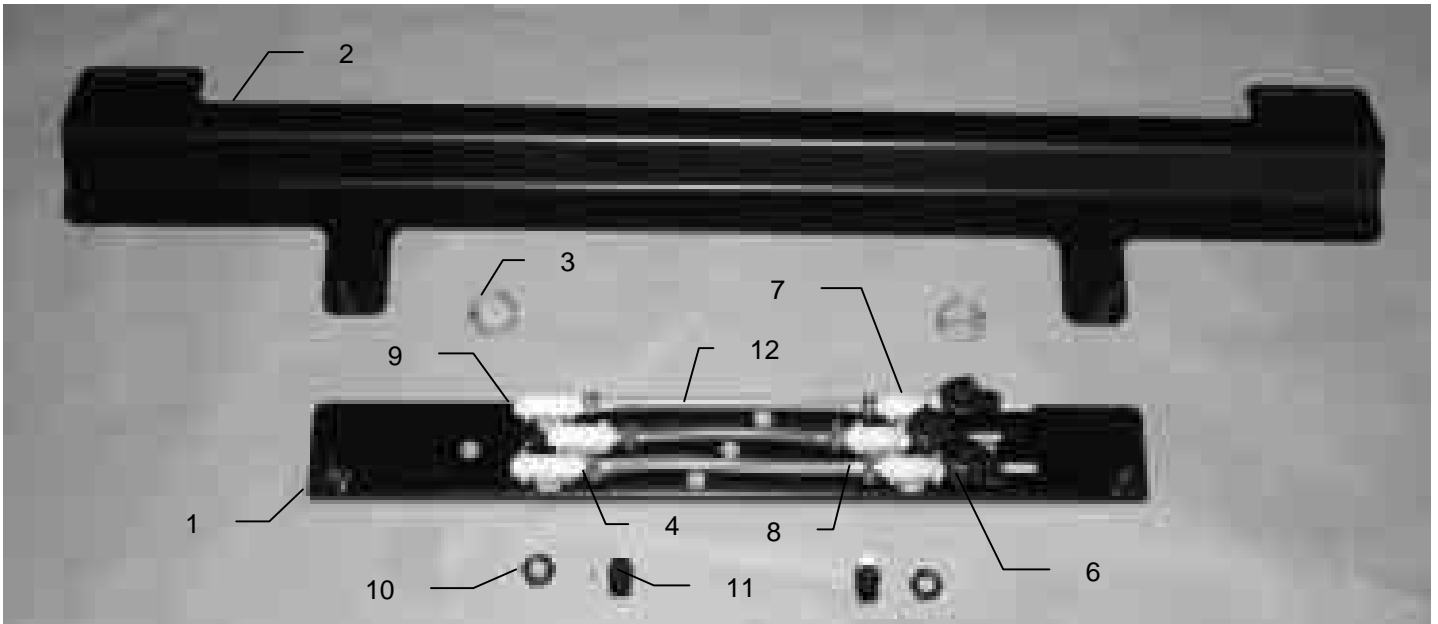

<u>Ref</u>	<u>Description</u>	<u>Part #</u>	<u>Qty</u>	<u>Description</u>	<u>Part #</u>	<u>Qty</u>
1	Spray Shield	001-4810	1	Tip	004-TT11001VP	2
2	Shield holder	001-4440A	1	Tip	004-TT110015VP	2
3	Lynch Pins	008-4576	2	Tip	004-TT11003VP	2
4	Hose Clamps	003-9002	9	Tip	004-800067-PT	2
5	Straight Fitting	003-A1414VB	3	Tip Strainers	004-1203-100	6
6	Check Valve	004-1207VB	3			
7	Tee	003-TT14SQ	3			
8	Straight Fitting	003-A1414	6			
9	90 degree elbow	003-SE14F	3			
10	Nozzle Cap	004-4723	9			
11	Nozzle Body	004-4722	6			
12	Hose	002-9016	3ft			

HARVEST TEC MODEL 4510B AUTO INSTALLATION KIT FOR VICON LB 8200 BALERS

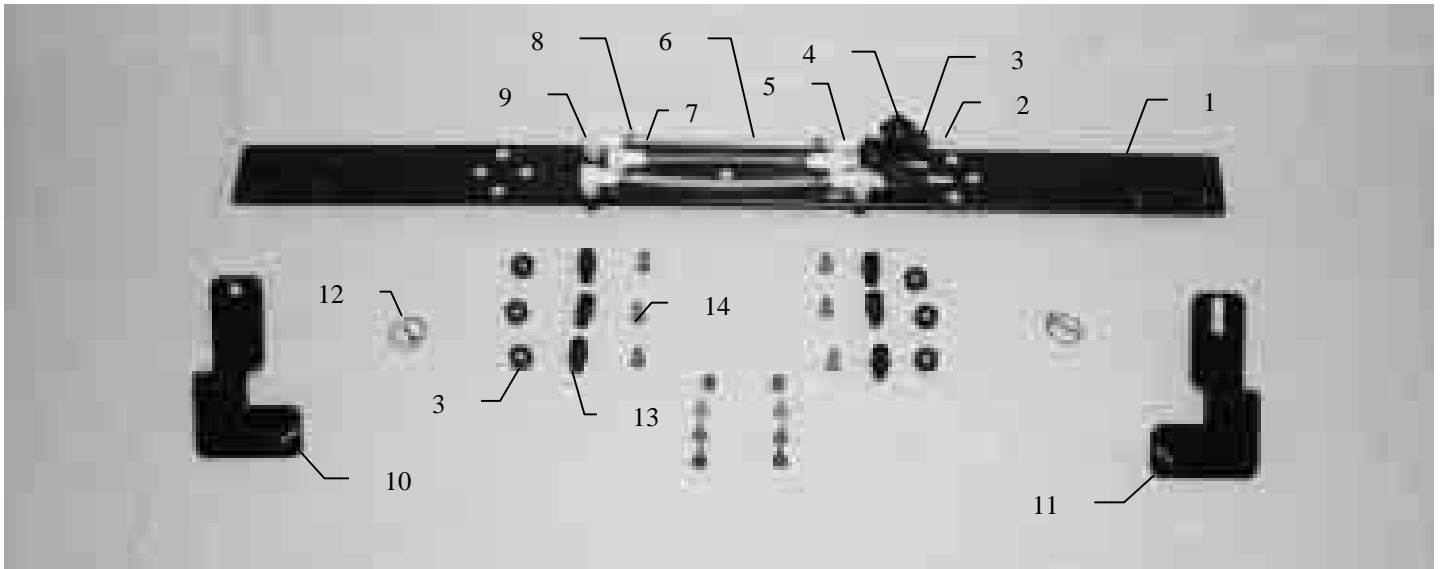

<u>Ref</u>	<u>Description</u>	<u>Part #</u>	<u>Qty</u>	<u>Description</u>	<u>Part #</u>	<u>Qty</u>
1	Spray shield	001-4811A	1	Tip	004-TT11001VP	2
2	Straight fitting	003-A1414VB	3	Tip	004-TT110015VP	2
3	Nozzle cap	004-4723	9	Tip	004-TT11003VP	2
4	Check valve	003-1207VB	3	Tip	004-800067-PT	2
5	Tee	003-TT14SQ	3			
6	Hose	002-9016	3			
7	Straight fitting	003-A1414	6			
8	Hose clamp	003-9002	9			
9	Elbow	003-SE14F	3			
10	Shield hanger	001-4704A	1			
11	Shield hanger	001-4704B	1			
12	Lynch pin	008-4576	2			
13	Nozzle body	004-4722	6			
14	Tip Strainers	004-1203-100	6			

HARVEST TEC MODEL 4511B AUTO INSTALLATION KIT FOR VICON LB 12200 BALERS

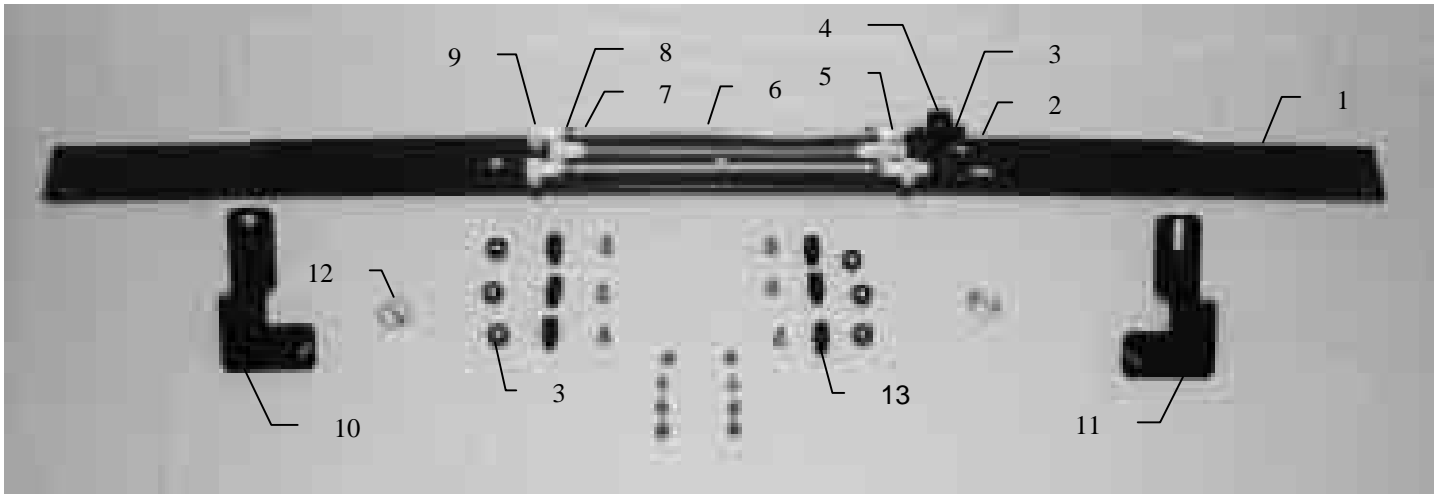

<u>Ref</u>	<u>Description</u>	<u>Part #</u>	<u>Qty</u>	<u>Description</u>	<u>Part #</u>	<u>Qty</u>
1	Spray shield	001-4704C	1	Tip	004-TT11001VP	2
2	Straight fitting	003-A1414VB	3	Tip	004-TT110015VP	2
3	Nozzle cap	004-4723	9	Tip	004-TT11003VP	2
4	Check valve	003-1207VB	3	Tip	004-800067-PT	2
5	Tee	003-TT14SQ	3	Tip Strainers	004-1203-100	6
6	Hose	002-9016	3			
7	Straight fitting	003-A1414	6			
8	Hose clamp	003-9002	9			
9	Elbow	003-SE14F	3			
10	Shield hanger	001-4704A	1			
11	Shield hanger	001-4704B	1			
12	Lynch pin	008-4576	2			
13	Nozzle body	004-4722	6			

HARVEST TEC MODEL 4514B INSTALLATION KIT FOR KRONE 890 – 12130 XC

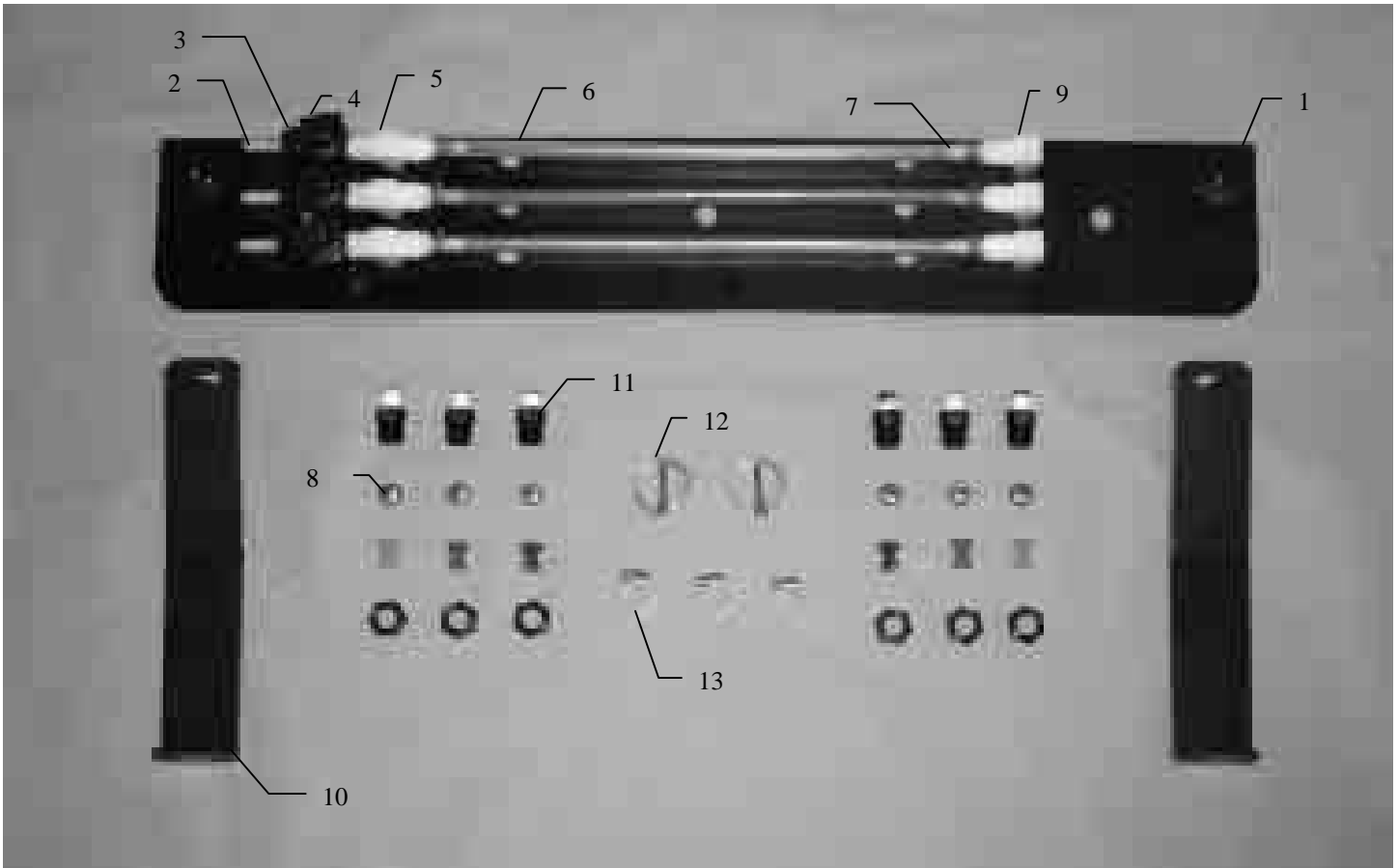

<u>Ref</u>	<u>Description</u>	<u>Part #</u>	<u>Qty</u>	<u>Description</u>	<u>Part #</u>	<u>Qty</u>
1	Spray shield	001-4431B	1	Tip	004-TT11001VP	2
2	Straight fitting	003-A1414VB	3	Tip	004-TT110015VP	2
3	Nozzle cap	003-4723	9	Tip	003-TT11003VP	2
4	Check valve	004-1207VB	3	Tip	004-800067-PT	2
5	Tee	003-TT14SQ	3			
6	Hose	002-9016	6			
7	Straight fitting	003-A1414	6			
8	Tip Strainers	004-1203-100	6			
9	Elbow	003-SE14F	3			
10	Shield holder	001-4431K	2			
11	Nozzle body	004-4722	6			
12	Lynch pin	008-4576	2			
13	Hose clamp	002-9002	9			

HARVEST TEC MODEL 4515B INSTALLATION KIT FOR KRONE 890 – 12130

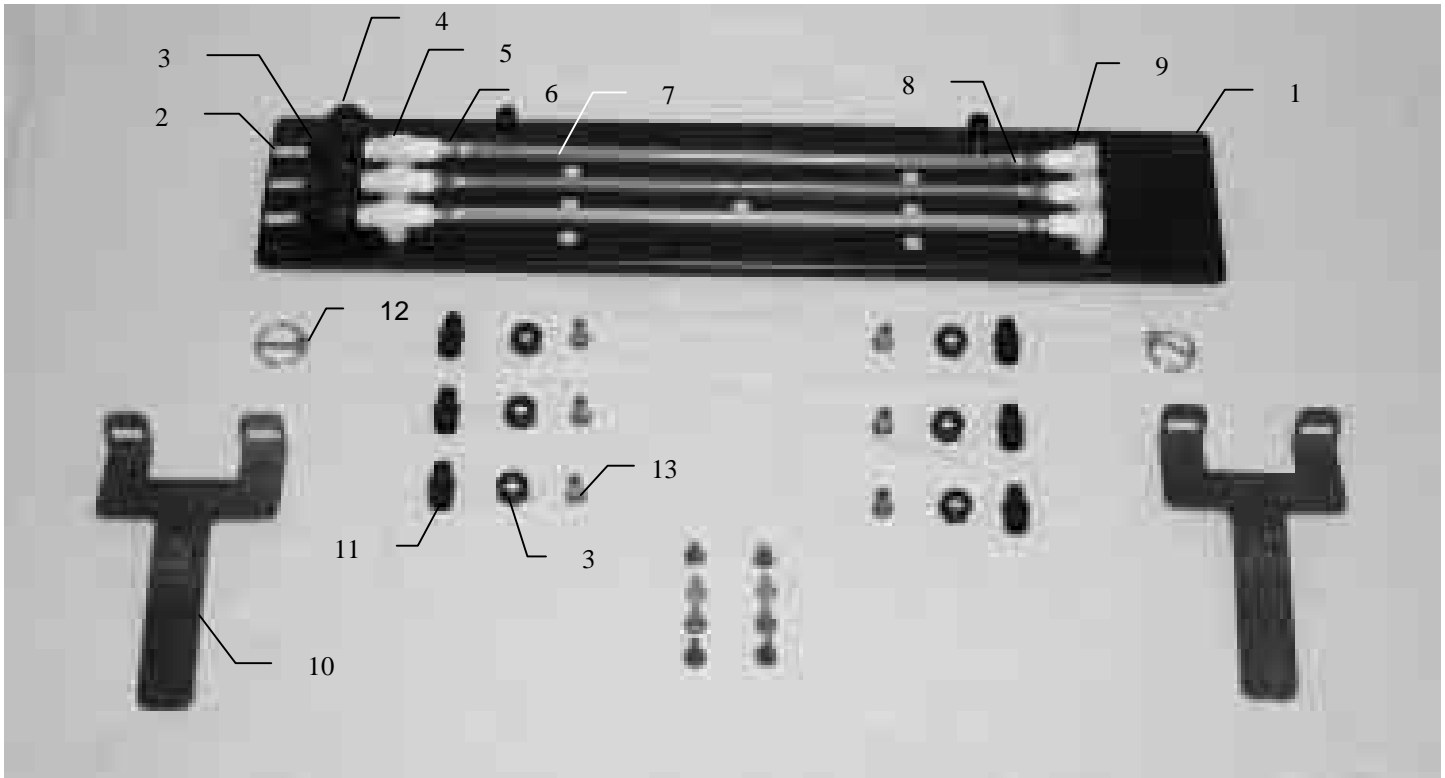

<u>Ref</u>	<u>Description</u>	<u>Part #</u>	<u>Qty</u>	<u>Description</u>	<u>Part #</u>	<u>Qty</u>
1	Spray shield	001-4435ES	1	Tip	004-TT11001VP	2
2	Straight fitting	003-A1414VB	3	Tip	004-TT110015VP	2
3	Nozzle cap	004-4723	9	Tip	004-TT11003VP	2
4	Check valve	004-1207VB	3	Tip	004-800067-PT	2
5	Tee	003-TT14SQ	3			
6	Hose clamp	003-9002	9			
7	Hose	002-9016	4			
8	Straight fitting	003-A1414	6			
9	Elbow	003-SE14F	3			
10	Shield holder	001-4435K	2			
11	Nozzle body	004-4722	6			
12	Lynch pin	008-4576	2			
13	Tip strainers	004-1203-100	6			

MODEL 4518 INSTALLATION KIT

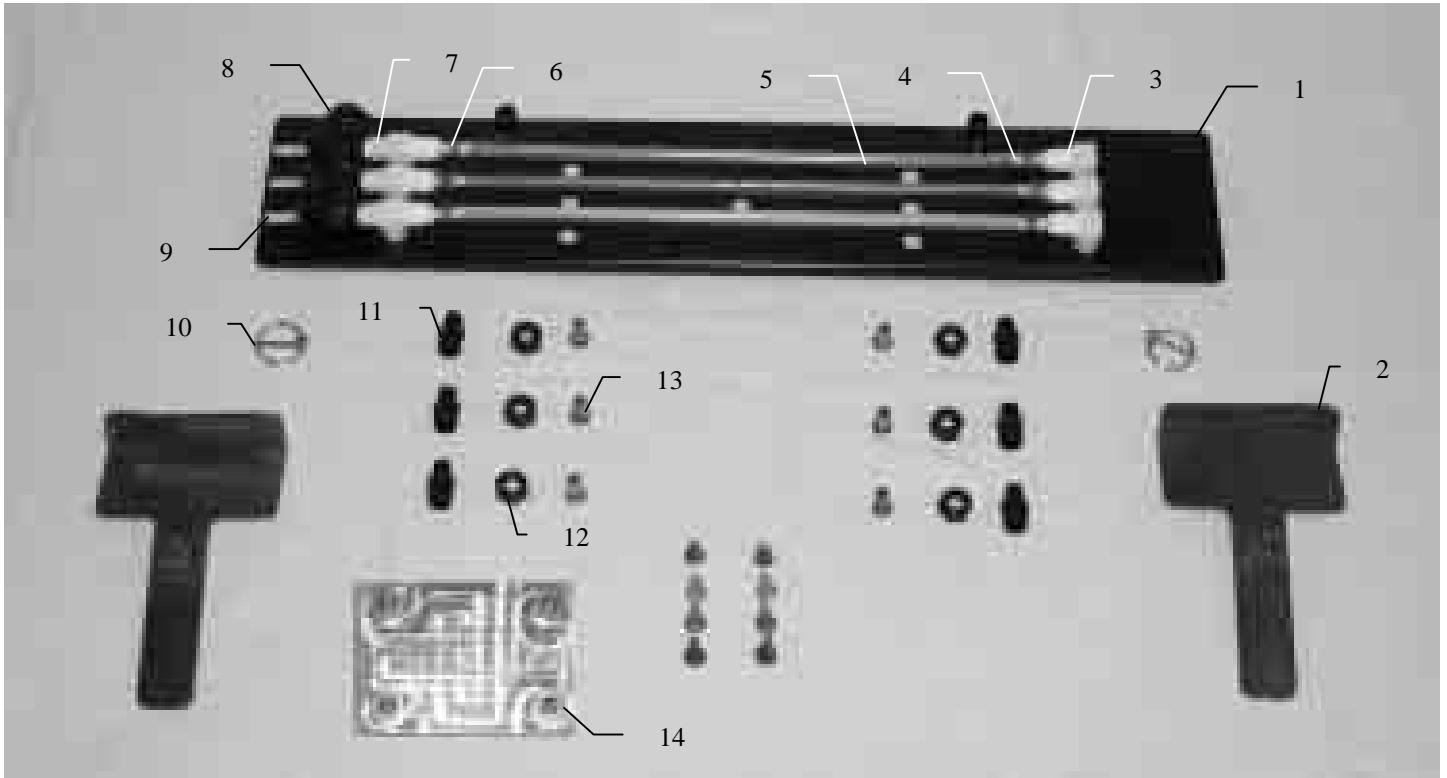

<u>Ref</u>	<u>Description</u>	<u>Part #</u>	<u>Qty</u>	<u>Description</u>	<u>Part #</u>	<u>Qty</u>
1	Spray shield	001-4435ES	1	Tip	004-800067-PT	2
2	Shield holder	001-4435H	2	Tip	004-TT11001VP	2
3	Elbow	003-SE14SQ	3	Tip	004-TT110015VP	2
4	Straight fitting	003-A1414	6	Tip	004-TT11003VP	2
5	Hose	002-9016	6			
6	Hose clamp	003-9002	9			
7	Tee	003-TT14SQ	3			
8	Check valve	004-1207VB	3			
9	Straight fitting	003-A1414VB	3			
10	Lynch pin	008-4576	2			
11	Nozzle body	004-4722	6			
12	Nozzle cap	004-4723	9			
13	Tip strainer	004-1203-100	6			
14	Star wheel spacer	001-6707E	2			

MODEL 4519 INSTALLATION KIT

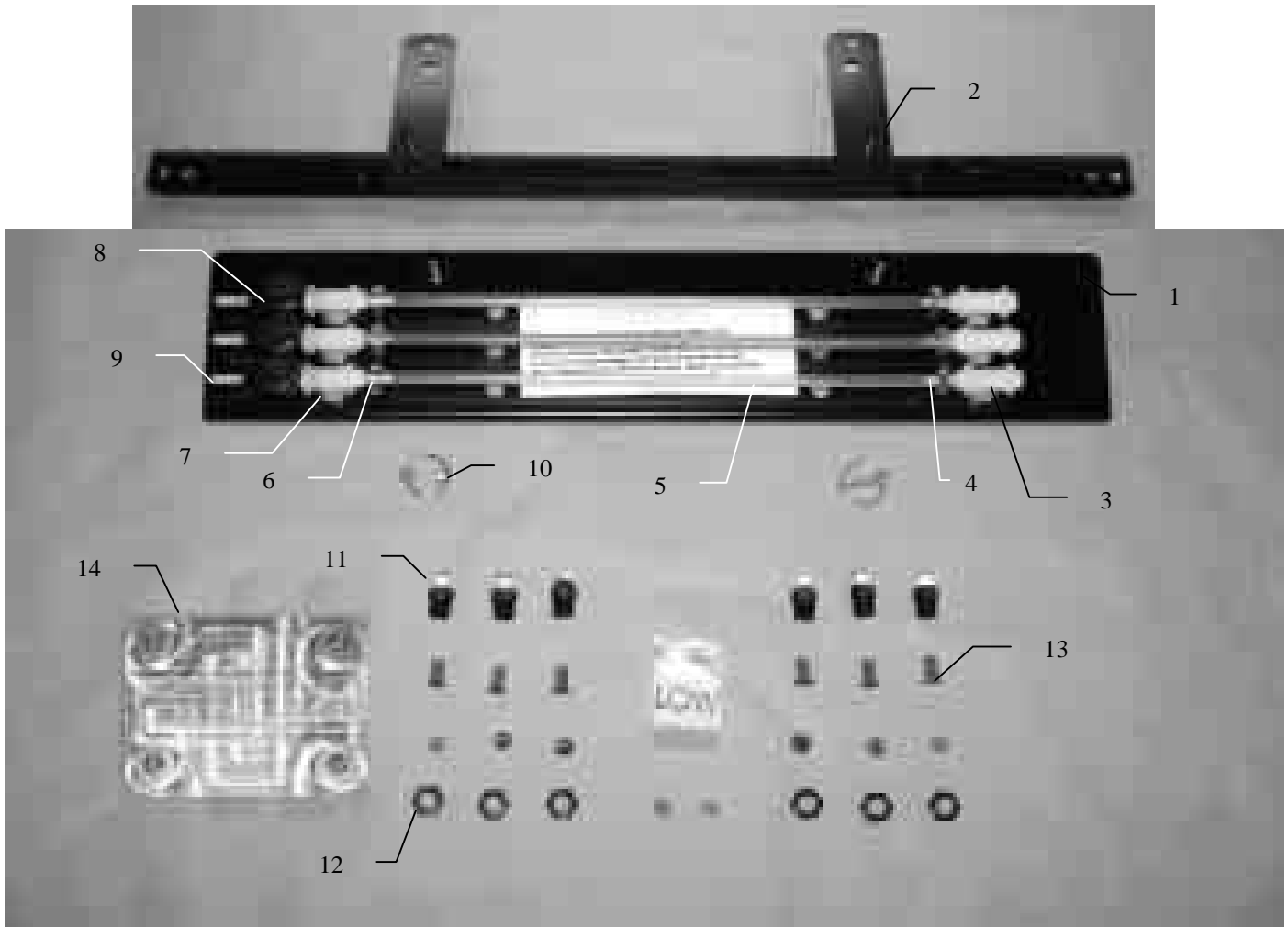

<u>Ref</u>	<u>Description</u>	<u>Part #</u>	<u>Qty</u>	<u>Description</u>	<u>Part #</u>	<u>Qty</u>
1	Spray shield	001-4435AS	1	Tip	004-800067-PT	2
2	Shield holder	001-4435J	1	Tip	004-TT11001VP	2
3	Elbow	003-SE14SQ	3	Tip	004-TT110015VP	2
4	Straight fitting	003-A1414	6	Tip	004-TT11003VP	2
5	Hose	002-9016	6			
6	Hose clamp	003-9002	9			
7	Tee	003-TT14SQ	3			
8	Check valve	004-1207VB	3			
9	Straight fitting	003-A1414VB	3			
10	Lynch pin	008-4576	2			
11	Nozzle body	004-4722	6			
12	Nozzle cap	004-4723	9			
13	Tip strainer	004-1203-100	6			
14	Star wheel spacer	001-6707E	2			

Vicon large square Template

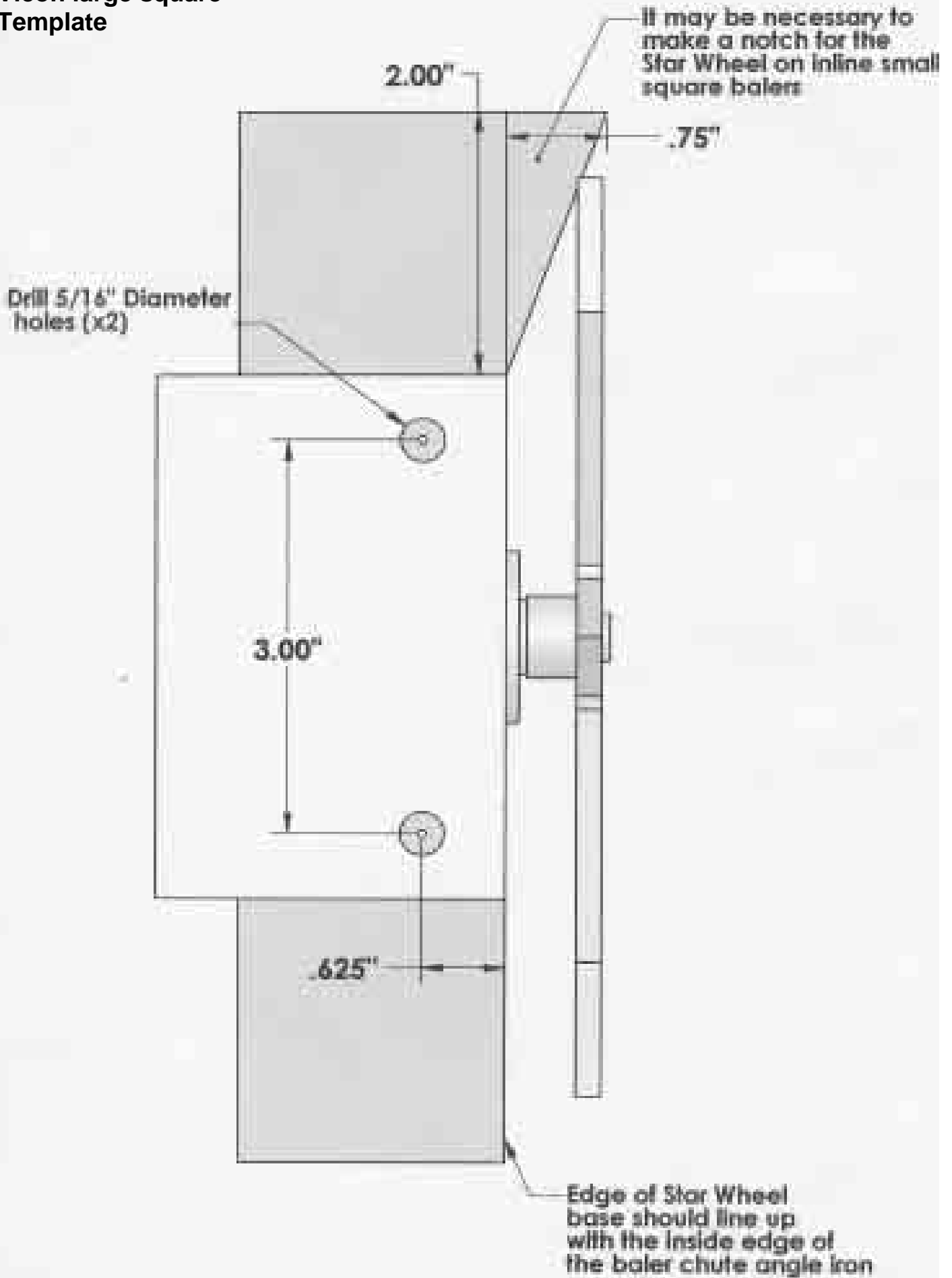

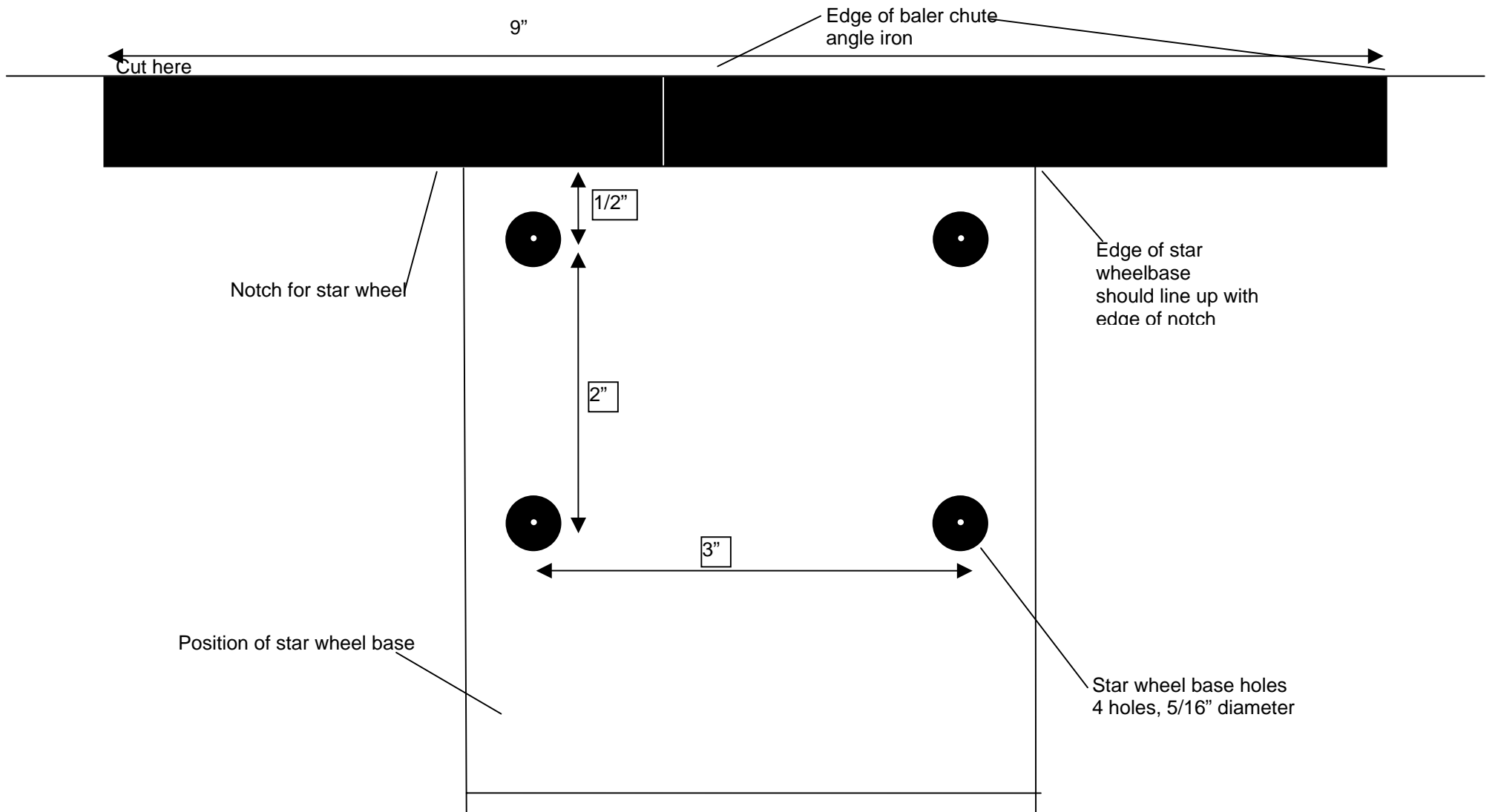

NOTES:

WARRANTY AND LIABILITY AGREEMENT

Harvest Tec, Inc. will repair or replace components that are found to be defective within 12 months from the date of manufacture. Under no circumstances does this warranty cover any components which in the opinion of Harvest Tec, Inc. have been subjected to negligent use, misuse, alteration, accident, or if repairs have been made with parts other than those manufactured and obtainable from Harvest Tec, Inc.

Our obligation under this warranty is limited to repairing or replacing free of charge to the original purchaser any part that in our judgment shows evidence of defective or improper workmanship, provided the part is returned to Harvest Tec, Inc. within 30 days of the failure. Parts must be returned through the selling dealer and distributor, transportation charges prepaid.

This warranty shall not be interpreted to render Harvest Tec, Inc. liable for injury or damages of any kind, direct, consequential, or contingent, to persons or property. Furthermore, this warranty does not extend to loss of crop, losses caused by delays or any expense prospective profits or for any other reason. Harvest Tec, Inc. shall not be liable for any recovery greater in amount than the cost or repair of defects in workmanship.

There are no warranties, either expressed or implied, of merchantability or fitness for particular purpose intended or fitness for any other reason.

This warranty cannot guarantee that existing conditions beyond the control of Harvest Tec, Inc. will not affect our ability to obtain materials or manufacture necessary replacement parts.

Harvest Tec, Inc. reserves the right to make design changes, improve design, or change specifications, at any time without any contingent obligation to purchasers of machines and parts previously sold.

Revised 01/03/06

HARVEST TEC, INC.
P.O. BOX 63
2821 HARVEY STREET
HUDSON, WI 54016
PHONE: 715-386-9100
1-800-635-7468
FAX: 715-381-1792
Email: info@harvesttec.com