

OWNER'S MANUAL

Model 442U *25 Gallon Preservative Applicators*



P.O. Box 63 • 2821 Harvey Street • Hudson, WI 54016
800-635-7468 • www.harvesttec.com

#010-0442U

Revised 11/11

HARVEST TEC 442U MANUAL INDEX

	<u>PAGE</u>
REFERENCE CHART	3
TOOLS NEEDED	3
INSTALLATION OF THE APPLICATOR	4 - 8
1. INSTALLATION OF TANK, MOUNTING BRACKETS, GAUGE, & DRAIN/FILL LINE	4-5
2. PLACEMENT OF SPRAY ASSEMBLY	6
3. INSTALLATION OF PLUMBING	7
A. INTAKE	7
B. OUTLET ROUND BALER	7
4. INSTALLATION OF CONTROLS	8
APPLYING RATE DECAL	8
LOCATION OF CONTROL BOX	8
WIRING	8
OPERATING INSTRUCTIONS	8
MESSAGE LIGHT	8
OPERATION	8-11
CALIBRATION	9-11
DETERMINING TONS PER HOUR	9
DETERMINING RATE OF CHEMICAL	10
SELECTING TIPS AND SETTING PRESSURE	10
CALIBRATION REMINDERS	10
GENERAL CALIBRATION CHARTS	11
ROUTINE MAINTENANCE	12
WINTER STORAGE	12
TROUBLE SHOOTING CHECKS	13
PARTS BREAKDOWN	14-15
MODEL 442U BASE KIT	14
MODEL 442U DRAIN/FILL, CONTROL BOX AND NOZZLE ASSEMBLY	15
NOTES	16
WARRANTY AND LIABILITY	BACK PAGE

Congratulations on purchasing a Harvest Tec Model 442U applicator. This applicator is designed to apply Harvest Tec buffered acid. The model 442U base kit includes the following parts: tank, frame, pump, gauge, hose, electronic control box, and miscellaneous hardware. For your convenience we have included a parts break down for the model 442U applicator. If something goes wrong bring this manual into the dealer so they can order the correct parts for you. Ordering the correct part number is very important. It will save you time, money, and your crop.

REFERENCE CHART

<u>BALER MODEL</u>	<u>HARVEST TEC MODEL</u>
CASE IH	
RB 455A	442U
NEW HOLLAND	
Roll-Belt 450	442U

TOOLS NEEDED

For installation of this applicator, the following tools will be required:

- Standard wrench set
- Standard socket set
- Standard screw driver or 5/16" nut driver
- Side cutter
- Hose cutter
- Crescent wrench
- Hammer

INSTALLATION OF APPLICATOR

1. INSTALLATION OF TANK, MOUNTING BRACKETS, GAUGE, & DRAIN/FILL LINE

Locate the tank base bracket (001-4442U). This bracket will mount on the front of the baler is show below. Depending on the year of the baler only two of the required three holes may be premade on the baler. Mark and drill two 1/2" holes (one per side) if necessary. Take care to check behind the area before drilling. The bracket will be secured on each side with three 1/2" x 1 – 1/4" hex bolts, six flat washers, three lock washers, and three hex nuts. Secure the left side of the baler first. Slide the supplied shims (001-4442US), if necessary, between the tank base bracket and the baler side wall if necessary. The shims need to be installed to prevent the balers side wall from moving in once the tank base bracket hardware is tightened. Tighten all hardware.

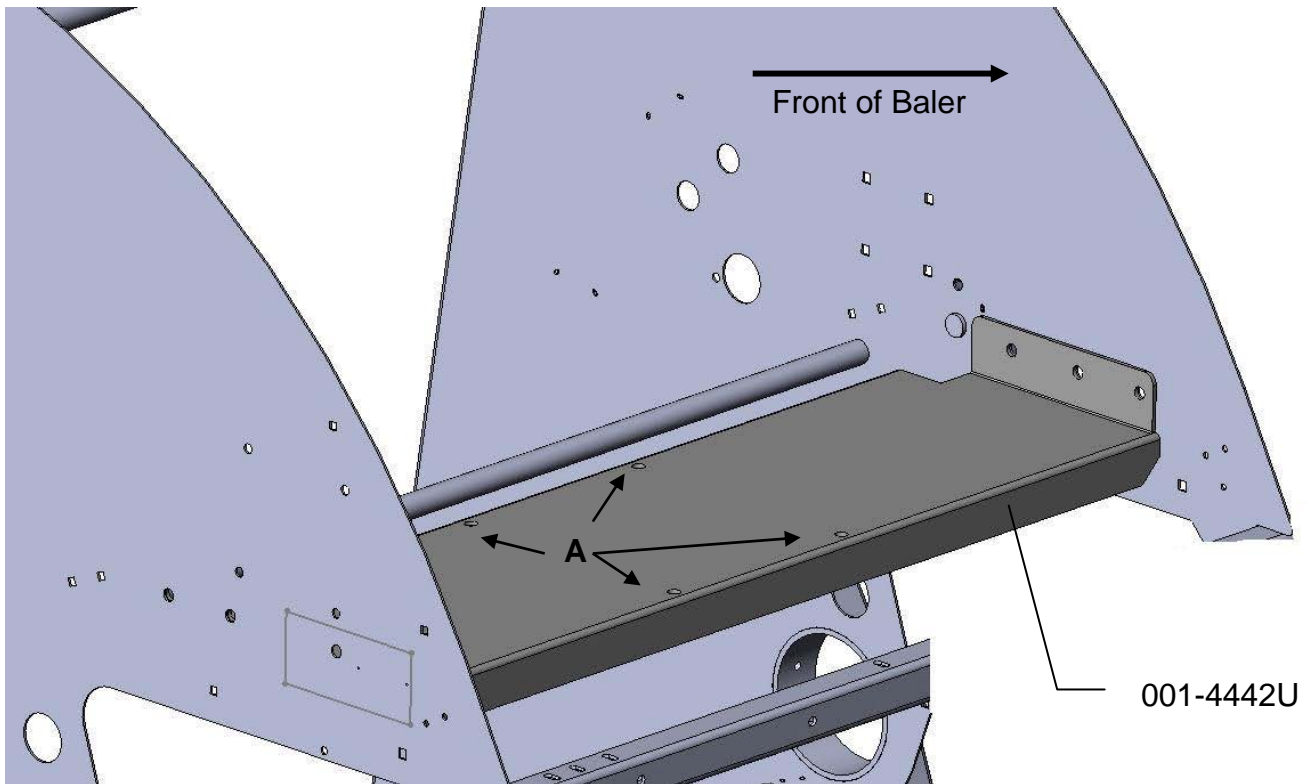

INSTALLATION OF TANK, MOUNTING BRACKETS, GAUGE, & DRAIN/FILL LINE CONT.

Mount the tank on the tank base bracket (001-442U) as shown below and on the previous page. The position the tank and saddle so that the additional side hole on the tank will be facing the front of the baler. The tank saddle will have four holes that will line up with point A. Use four 1/2" x 1 – 1/4" hex bolts, four flat washers, and four lock washers to secure the tank to points A.

The drain/fill line will connect to the tank at point B. Thread 3/4" elbow fitting (#003-EL3434) into end of tank. Run 3/4" hose from the elbow down the frame to the bottom of the baler. Drill 1/4" holes to accept the valve holder bracket and use 5/16" x 1 1/4" self-tapping screws. Connect valve assembly to other end of hose. Place hose clamps on both ends. **The drain/fill line needs to be used for all filling or draining of the tank. Fill or drain from ground level only. Failure to do so can lead to injury.**

Locate gauge assembly. On round balers the gauge can be mounted to front of tank saddle or in any other location that is easily viewed from the tractor's seat.

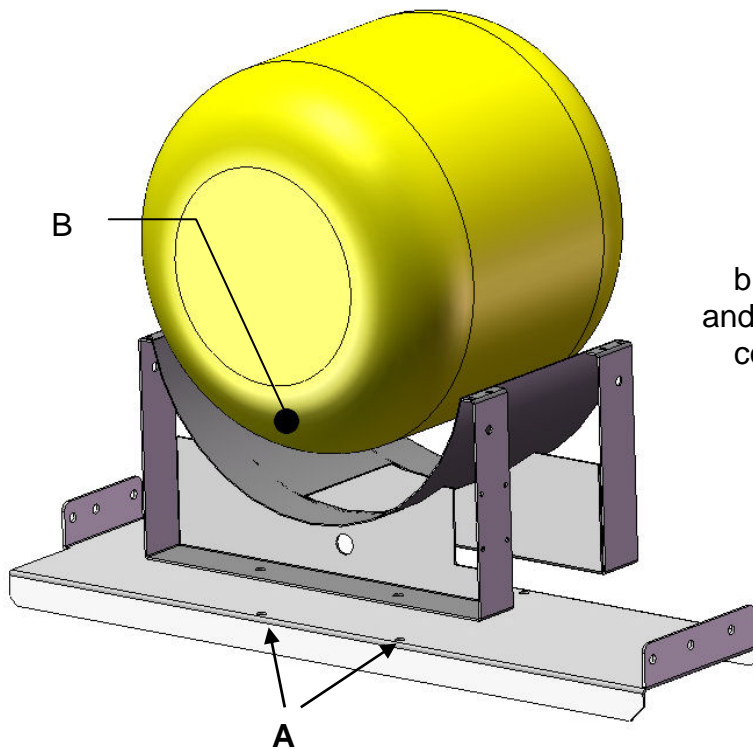

Valve bracket and quick coupler

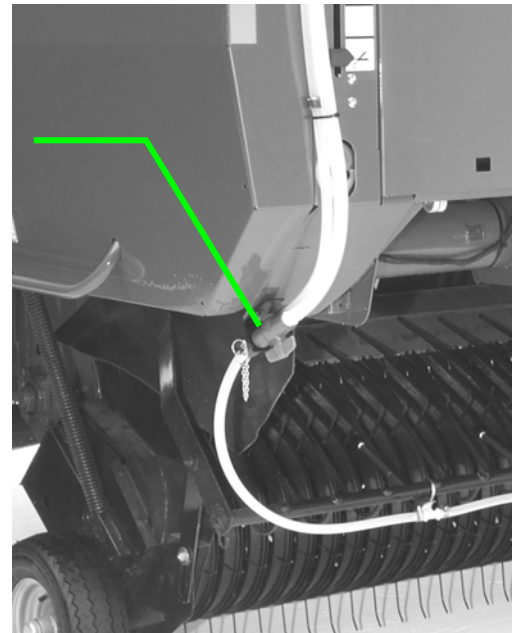

2. INSTALLATION OF SPRAY NOZZLE ASSEMBLY

The cross bar on the wind guard above the pick-up head provides a mounting point for the nozzle pipes. Space the nozzles by the chart below:

PICK-UP HEAD WIDTH	LEFT SIDE (Use plugged fitting)	CENTER (Use 2-way fitting)	RIGHT SIDE (Use 2-way fitting)
48"	12" from left	Center	12" from right
60"	14" from left	Center	14" from right
72"	15" from left	Center	15" from right

Aim the nozzle pipes up so that the tips spray in a generally horizontal direction. The tips should be pointed toward the starter rolls of the baler. The tips should be located so they will be somewhere between 14" and 18" from the normal path of hay.

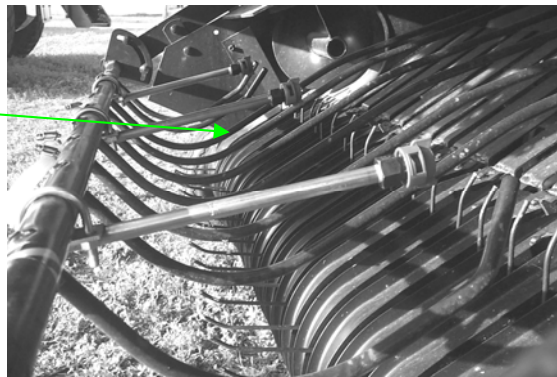
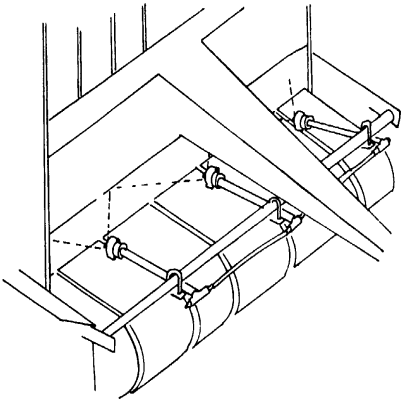

3. INSTALLATION OF PLUMBING

A. INTAKE

Screw the 003-EL3412 (3/4" to 1/2" elbow) into the bottom of the tank. Second screw the 002-2212 (1/2" ball valve) with elbow into the filter assembly. Lastly, route the 002-9001 (1/2" hose) from bottom of the tank to ball valve. Secure with hose clamps.

B. OUTLET ROUND BALER

Run hose from the pump outlet to the gauge. The gauge is assembled with two straight fittings; an elbow is supplied in the parts bag to be used if necessary. From the gauge the hose will need to be run to the first nozzle tube with the check valve. On John Deere 8 series and Agco balers the hose from the gauge will go the check valve on the spray shield. Cut the hose to length and attach the female disconnect and straight fitting. Attach these to the check valve using one washer.

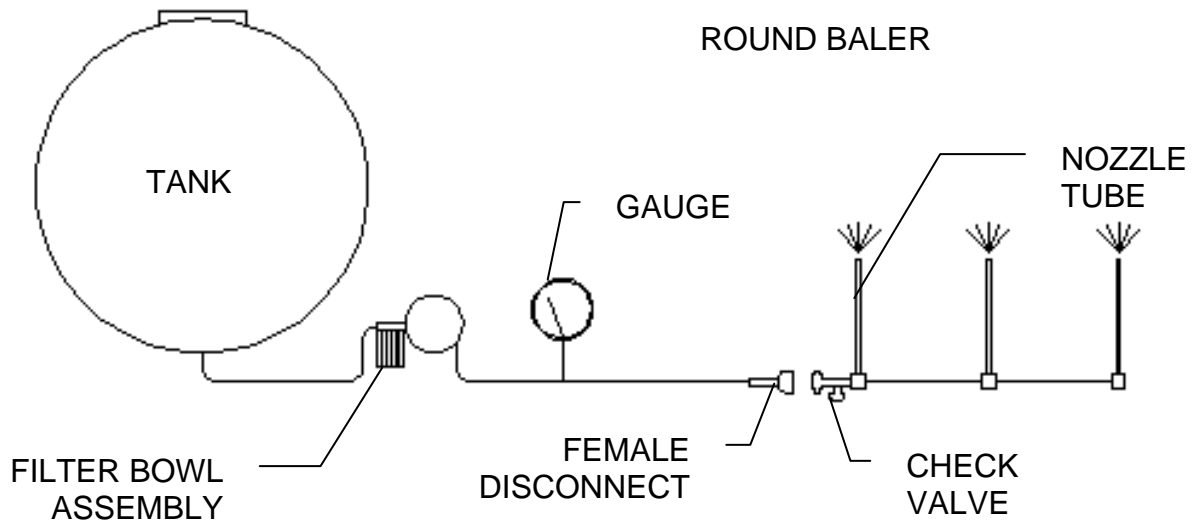

4. INSTALLATION OF CONTROLS

APPLY RATE DECAL

Apply the rate decal that came in the bag with this book and place it just to the right of the speed dial.

LOCATION OF CONTROL BOX

Locate the control where it can be easily reached from the tractor's seat. Adjustments for baling speed and windrow conditions can be made as the baler is operated.

WIRING

Route the wire to the starter solenoid on all 12v tractors. Connect the green lead marked + to the hot terminal on the starter. Connect the black lead to a good ground. **DO NOT REVERSE THE LEADS.** Be sure to use a voltmeter to verify that you do have 12 volts running to the box.

NOTE: For tractors with 24v starters, connect the power leads to the tractor's right hand battery. Do not connect the leads to the starter. Connect the lead marked + to the positive battery terminal and the lead marked - to the negative on the battery. Wiring connections to the battery normally results in corrosion; terminal coating is recommended.

CAUTION: Do not run a pump or use an electronic control box directly off a battery charger. For stationary use, the applicator can be connected to a new battery and the battery connected to a charger.

OPERATING INSTRUCTIONS

The 442U applicator is very simple to operate. After installing the applicator, fill the tank with 5 gallons of water. With control box connected to the applicator and the power cord hooked to the 12-volt battery we can start the test. First flip on the toggle switch. You might hear the buzzing of the motor. Turn the dial on the control box until the gauge starts to climb. By turning the dial clockwise the pressure will go up. By turning the dial counter clockwise the pressure will decrease. With the applicator spraying at about 30 PSI, look for leaks at all the hose connections and fittings. Using water in this step instead of chemical will save you from wasting chemical and making a mess if leaks are found. When you are comfortable with the operation of the controls you can set the applicator to apply the amount of chemical you would like it to put on.

Message Light

The LED under the speed dial will be steady on when the applicator is running under normal situations. If the light blinks on and off use the below information for the message.

Slow steady on and off blink: The system is attached to hay indicators (474A) or a foot switch. This message means that the pump is paused. The light will come on constant once the baler is back in the windrow.

Two quick blinks: The pump motor or pump harness is shorted.

Three quick blinks: Pump motor is over the current limit (10 amps).

Four quick blinks: Power is under current from a bad connection.

The control box must have the on/off switch toggled to clear the message after the fault has been fixed to clear.

CALIBRATION

There are three things that you need to know when calibrating your applicator. First you need to know how many tons per hour you bale. Second you need to know the rate, or how many pounds of product to apply for a given ton per hour. Finally you need to know what tips to use and at what pressure to set the gauge.

DETERMINING TONS PER HOUR

Round Balers

1. Time 3 bales and average the time it takes to make a bale.
2. Estimate the weight of the bale.
3. Use the bale rate chart below to determine the tons you are baling per hour.

Example: You made 3 round bales and it took you an average of 2 minutes a piece to bale each of them. Your baler's operator manual tells you that an average bale made by your machine weighs 1000lb. (Remember if the hay is dry it will weigh less and if the hay is wet it will weigh more.) Using the chart below, cross-reference 2 minutes with 1000lb. and you will come up with 15 ton per hour.

Average
time to
make a
bale
(min.)

Round Baler (Tons per Hour)

Weight per Baler

	600	800	1000	1200	1400	1600	1800	2000	2200
0.5	36.0	48.0	60.0	72.0	84.0	96.0	108.0	120.0	132.0
1	18.0	24.0	30.0	36.0	42.0	48.0	54.0	60.0	66.0
1.5	12.0	16.0	20.0	24.0	28.0	32.0	36.0	40.0	44.0
2	9.0	12.0	15.0	18.0	21.0	24.0	27.0	30.0	33.0
2.5	7.2	9.6	12.0	14.4	16.8	19.2	21.6	24.0	26.4
3	6.0	8.0	10.0	12.0	14.0	16.0	18.0	20.0	22.0
3.5	5.1	6.9	8.6	10.3	12.0	13.7	15.4	17.1	18.9
4	4.5	6.0	7.5	9.0	10.5	12.0	13.5	15.0	16.5
4.5	4.0	5.3	6.7	8.0	9.3	10.7	12.0	13.3	14.7
5	3.6	4.8	6.0	7.2	8.4	9.6	10.8	12.0	13.2
5.5	3.3	4.4	5.5	6.5	7.6	8.7	9.8	10.9	12.0
6	3.0	4.0	5.0	6.0	7.0	8.0	9.0	10.0	11.0
6.5	2.8	3.7	4.6	5.5	6.5	7.4	8.3	9.2	10.2
7	2.6	3.4	4.3	5.1	6.0	6.9	7.7	8.6	9.4
7.5	2.4	3.2	4.0	4.8	5.6	6.4	7.2	8.0	8.8
8	2.3	3.0	3.8	4.5	5.3	6.0	6.8	7.5	8.3
8.5	2.1	2.8	3.5	4.2	4.9	5.6	6.4	7.1	7.8
9	2.0	2.7	3.3	4.0	4.7	5.3	6.0	6.7	7.3
9.5	1.9	2.5	3.2	3.8	4.4	5.1	5.7	6.3	6.9
10	1.8	2.4	3.0	3.6	4.2	4.8	5.4	6.0	6.6

DETERMINING THE RATE OF CHEMICAL

The number of pounds of chemical required to be applied to a given ton of hay, depends on the moisture and the type of chemical used. The moisture of the hay is important in determining how much chemical to use. The wetter the hay the more product is needed, the dryer the hay the less product is needed. By knowing the moisture, you can make sure you are treating the hay correctly. Under applying will save money but spoilage most likely occurs. Over applying will waste money however, the hay will be saved. Some chemicals require more or less to treat the same amount of hay. To find the exact number of pounds required, for a given hay moisture, refer to the label on the drum or contact the manufacture. Harvest Tec applicators come with low, medium, and high sets of tips. If your chemical requires rates other than what these tips deliver you will need to purchase them through your dealer.

SELECTING TIPS AND SETTING PRESSURE FOR ROUND BALERS

Once you have determined your tons per hour and the amount of chemical needed for the moisture you are applying at, you can select your tips and determine your gauge settings.

1. Multiply the tons per hour by the amount of chemical required for the moisture you are applying at. This sum will give you the application rate.
2. Select the proper set of tips from the application rate chart and install them. (Pg.29-30)
3. For the tips you have selected, you will need to keep the gauge at the recommended PSI to achieve the proper application rate.
4. Set the pressure by adjusting the dial on the control box and by reading the pressure of the gauge to match the desired rates. The numbers on the dial are for reference only. Rate is determined by watching the pressure gauge.

Example: You are baling at 22 tons per hour with your round baler. The moisture that you are baling at requires you to apply 8 pounds per ton. Multiply the 22 tons x 8lbs. = 176lbs. per hour. Using the chart, lbs/hr with three nozzles, on page 12, you will notice the green set of tips at 35 PSI will give you that output.

CALIBRATION REMINDERS

*Watch the pressure gauge, as the setting will vary with tractor's electrical output, temperature and other factors.

*Check your application rate by measuring product used against actual tons baled.

REMEMBER, ONLY YOU CAN CONTROL HOW MUCH PRODUCT IS APPLIED AND THAT WILL DETERMINE IF YOUR HAY WILL KEEP!!!

GENERAL CALIBRATION CHART IN POUNDS PER HOUR

Use the following chart for all applications that require pounds measurements.

POUNDS PER HOUR WITH THREE NOZZLES

	YELLOW 650067 650033	INCLUDED IN KIT			BLACK XR11004 6503	CENTER OUTSIDE
		RED XR11001 650050	GREEN XR110015 6501	BLUE XR11002 6502		
		PSI	53	64		
15	53	64	112	192	320	
20	63	76	133	228	380	
25	70	84	147	252	420	
30	77	92	161	276	460	
35	84	100	175	300	N/A	
40	89	106	186	318	N/A	
45	94	112	196	336	N/A	
50	97	116	203	348	N/A	
55	102	122	214	366	N/A	
60	107	128	224	384	N/A	

GENERAL CALIBRATION CHART IN GALLONS PER HOUR

Use the following chart for all applications that require volume measurements.

GALLONS PER HOUR WITH THREE NOZZLES

	YELLOW 650067 650033	INCLUDED IN KIT			BLACK XR11004 6503	CENTER OUTSIDE
		RED XR11001 650050	GREEN XR110015 6501	BLUE XR11002 6502		
		PSI	5.2	7.3		
15	5.2	7.3	12.9	22.0	31.9	
20	5.6	8.4	15.1	24.1	42.2	
25	6.3	9.5	16.7	28.3	47.3	
30	7.0	10.6	18.6	31.0	52.2	
35	7.5	11.3	19.7	33.5	N/A	
40	8.0	12.0	21.0	36.0	N/A	
45	8.4	12.6	22.3	38.3	N/A	
50	8.9	13.2	23.6	40.7	N/A	
55	9.3	13.8	24.5	42.5	N/A	
60	9.7	14.4	25.6	44.4	N/A	

ROUTINE MAINTENANCE

1. **Clean the tip strainers and main strainer** every 10 hours of operation or more frequently if required.
2. Depending on the product being used, the system may need to be flushed with water at a regular interval (consult with manufacturer of the chemical.) If Harvest Tec product is being used, flushing is not necessary.
3. Although the pump can run dry, extended operation of a dry pump will increase wear. Watch the preservative level in the tank.
4. Cover the electronic cab control box on open station tractors if left outside.
5. Pump performance may start to decline after 400 hours of use. Rebuilding the pump is a simple procedure if the motor is not damaged. Order pump rebuilding kit #007-4581.
6. If you are using bacterial inoculants, flush out system daily after each use.
7. Clean tank cap breather every 20 hrs or more frequently if required.
8. **WARNING: Do not climb on baler for maintenance.**

WINTER STORAGE

1. Thoroughly flush the system with water.
2. Remove the filter bowl and run dry until the water has cleared out of the intake side.
3. Remove the red plug from the bottom of the pump, drain, and run the pump for 30 seconds or until it is dry.
4. Drain all lines on the outlet side.
5. Never use oils or alcohol based anti-freeze in the system.
6. For spring start-up, or anytime the pump is frozen, turn off the power immediately to avoid burning the motor out. The pump head can be disassembled and freed or rebuilt in most cases.
7. The drain/fill line needs to be used for all filling and draining of the tank. Fill or drain from ground level only. Failure to do so can lead to injury.

TROUBLE SHOOTING CHECKS

PROBLEM	POSSIBLE CAUSE	SOLUTION
Pump will not run.	1. Circuit breaker tripped on electronic unit.	1. Check for short, low voltage, and reset breaker.
	2. Pump locked up.	2. Clean or rebuild pump if motor is OK.
	3. Damaged wire.	3. Repair damaged wire.
	4. Vapor locked.	4. Loosen hose by check valve at spray shield and bleed air.
Pump runs but will not prime.	1. Air leak in intake.	1. Tighten fittings on intake side.
	2. Clogged intake.	2. Clean.
	3. Restricted outlet.	3. Check and clean tips.
	4. Check valve on outlet stuck closed.	4. Clean or repair check valve.
	5. Dirt inside pump.	5. Replace pump check valve.
Pump does not develop enough output.	1. Air leaks or clogs on inlet side.	1. Tighten or clean filter bowl assembly.
	2. Electronic box out of adjustment.	2. Refer to box adjustment page.
	3. Pump worn or dirty.	3. Rebuild pump.
	4. Low supply voltage. (Pump requires 12v minimum)	4. Check voltage at connection with voltmeter.
	5. Bad gauge.	5. Gauge should read less than 10 PSI when not in use. Also tips should lose spray pattern below 10 PSI. Check accuracy.
Pump output varies.	1. Clogged or restricted inlet.	1. Clean
	2. Worn pump parts.	2. Rebuild pump.
Message light blinks two times	1. Pump or wire harness shorted.	1. Check harness running to pump and verify no shorts or problems. 2. Check to see if pump motor is locked up. Repair or replace.
Message light blinks three times	1. Pump is drawing greater than 10 amps.	1. Check to see if motor is running correctly. Repair or replace.
Message light blinks four times	1. Undercurrent coming to control box.	1. Check all battery connections and connections running up to control box.

MODEL 442U BASE KIT

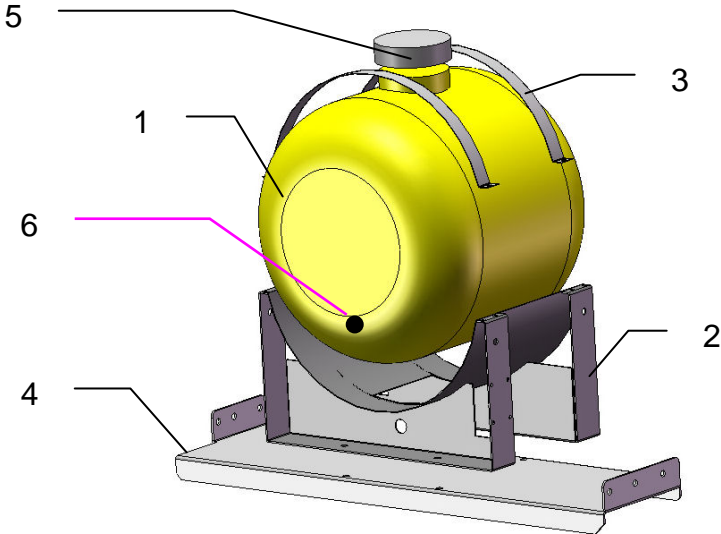

<u>Ref</u>	<u>Description</u>	<u>Part #</u>	<u>Qty</u>
1	Tank	005-9022	1
2	Tank saddle	001-4442	1
3	Strap	001-4402	2
4	Tank mounting bracket	001-4442U	1
5	Lid	005-9022C	1
	Lid gasket	005-9022CG	1
6	Tank fitting	005-9100	2
NP	Shims	001-4442US	4

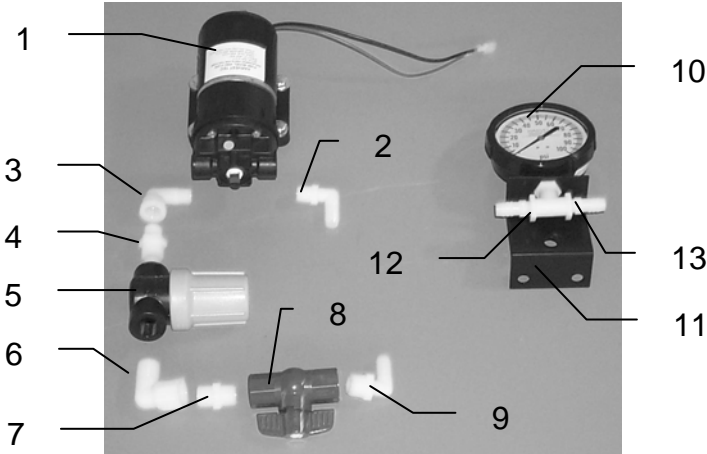

<u>Ref</u>	<u>Description</u>	<u>Part #</u>	<u>Qty</u>	<u>Ref</u>	<u>Description</u>	<u>Part #</u>	<u>Qty</u>
1	Pump	007-4120S	1	8	Ball valve	002-2212	1
2	Elbow fitting	003-EL3812	1	9	Elbow fitting	003-EL1212	1
3	Street elbow	003-SE38	1	10	Gauge	002-2208Z	1
4	Nipple fitting	003-M1238	1	11	Gauge bracket	001-4717	1
5	Filter bowl assembly	002-4315	1	12	Tee	003-TT14	1
6	Street elbow	003-SE12	1	13	Straight fitting	003-A1412	2
7	Nipple fitting	003-M1212	1				

MODEL 442 DRAIN/FILL KIT, CONTROL BOX, & NOZZLE ASSEMBLY

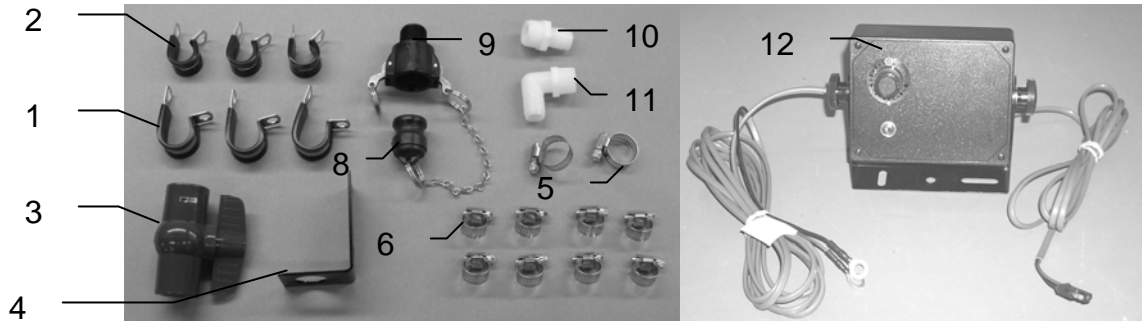

<u>Ref</u>	<u>Description</u>	<u>Part #</u>	<u>Qty</u>	<u>Ref</u>	<u>Description</u>	<u>Part #</u>	<u>Qty</u>
1	Jiffy clip-large	008-9009	3	8	Male shut-off	002-2205G	1
2	Jiffy clip-small	008-9010	3	9	Female coupler	002-2204A	1
3	Ball valve	002-2200	1	10	Straight fitting	003-A3434	1
4	Valve bracket	001-6702H	1	11	Elbow fitting	003-EL3434	1
5	Hose clamp	003-9003	5	12	Control box**	030-0457	1
6	Hose clamp	003-9004	2				

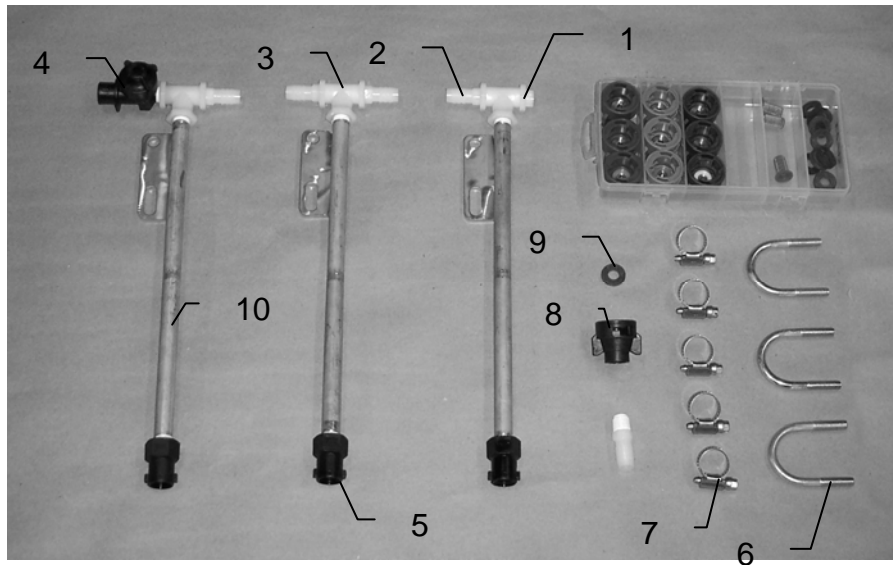

<u>Ref</u>	<u>Description</u>	<u>Part#</u>	<u>Qty</u>	<u>Description</u>	<u>Part#</u>	<u>Qty</u>
1	Plug	003-F14	1	Tip Kit (Complete)	030-9002	1
2	Straight fitting	003-A1412	5	Tip Kit Includes:		
3	Tee	003-TT14	3	Plastic Box	008-9000	1
4	Check valve	004-1207V	1	Red Cap	004-1207B	3
5	Female coupler	004-1207G	3	Outside Tip (Red Set)	004-650050-SS	2
6	U bolt	001-4714UBS	3	Inside Tip (Red Set)	004-XR11001VS	1
7	Hose clamp	003-9003	5	Green Cap	004-1207A	3
8	Female disconnect	004-1207H	1	Outside Tip (Green Set)	004-6501-SS	2
9	Washer	004-1207W	1	Inside Tip (Green Set)	004-XR110015VS	1
10	Nozzle tube	001-4714	3	Blue Cap	004-1207C	3
				Outside Tip (Blue Set)	004-6502-SS	2
				Inside Tip (Blue Set)	004-XR11002VS	1
				Washer	004-1207W	9
				Tip Strainer	004-1203-100	3

NOTES:

WARRANTY AND LIABILITY AGREEMENT

Harvest Tec, Inc. will repair or replace components that are found to be defective within 12 months from the date of manufacture. Under no circumstances does this warranty cover any components which in the opinion of Harvest Tec, Inc. have been subjected to negligent use, misuse, alteration, accident, or if repairs have been made with parts other than those manufactured and obtainable from Harvest Tec, Inc.

Our obligation under this warranty is limited to repairing or replacing free of charge to the original purchaser any part that in our judgment shows evidence of defective or improper workmanship, provided the part is returned to Harvest Tec, Inc. within 30 days of the failure. Parts must be returned through the selling dealer and distributor, transportation charges prepaid.

This warranty shall not be interpreted to render Harvest Tec, Inc. liable for injury or damages of any kind, direct, consequential, or contingent, to persons or property. Furthermore, this warranty does not extend to loss of crop, losses caused by delays or any expense prospective profits or for any other reason. Harvest Tec, Inc. shall not be liable for any recovery greater in amount than the cost or repair of defects in workmanship.

There are no warranties, either expressed or implied, of merchantability or fitness for particular purpose intended or fitness for any other reason.

This warranty cannot guarantee that existing conditions beyond the control of Harvest Tec, Inc. will not affect our ability to obtain materials or manufacture necessary replacement parts.

Harvest Tec, Inc. reserves the right to make design changes, improve design, or change specifications, at any time without any contingent obligation to purchasers of machines and parts previously sold.

Revised 01/03/06

HARVEST TEC, INC.
P.O. BOX 63
2821 HARVEY STREET
HUDSON, WI 54016
PHONE: 715-386-9100
1-800-635-7468
FAX: 715-381-1792
Email: info@harvesttec.com